

# ***INTELLISPEC™***

## **System Guide Series V CSL**

Pressco Technology Inc.

**69622 Rev. 03**



Original Instructions

---

© 2014 Pressco Technology Inc. All rights reserved.

No part of this manual may be reproduced or transmitted in any form or by any means, electronic or mechanical, including photocopying and recording, for any purpose, without the express written permission of Pressco Technology Inc.

The contents of this manual are furnished for informational use only, are subject to change without notice, and should not be construed as a commitment by Pressco Technology Inc.

Written and designed at:

Pressco Technology Inc. World Headquarters

29200 Aurora Road

Cleveland, OH USA 44139-1847

TEL 440-498-2600

FAX 440-498-2615

[www.pressco.com](http://www.pressco.com)

# Table of Contents

---

<b>Chapter 1 Introduction .....</b>	<b>5</b>
Welcome!.....	5
About the Intellispec Series V Compact Single Lane (CSL) System .....	5
About this manual.....	6
Typographical Conventions.....	6
Safety Considerations .....	7
Static Discharge Protection.....	7
<b>Chapter 2 Safety Information .....</b>	<b>9</b>
Symbols.....	9
Warning Devices .....	11
Residual Risk .....	12
Intended Use.....	12
Non-intended use .....	13
Personal Protective Equipment .....	13
Personnel Safety .....	14
Lifting heavy objects .....	15
Authorized Users.....	16
Spare Parts Usage .....	16
<b>Chapter 3 System Specifications .....</b>	<b>17</b>
Environmental conditions .....	17
Specifications .....	18
Declaration of Conformity - Intellispec™ CSL System .....	23
Declaration of Conformity - Integrated Tunnel .....	24
<b>Chapter 4 Installation and Wiring .....</b>	<b>25</b>
Shipping and Handling .....	25
Recommendations prior to installation .....	26
System Block Diagram - CSL.....	27
Assembly, location, and mounting requirements.....	27
Commissioning.....	30
<b>Chapter 5 Navigating Through the System.....</b>	<b>31</b>
Intellispec CSL cabinet and user interface .....	31
User interface input devices .....	32
User Interface Display - 4 Levels .....	36
Menu Toolbar .....	42
Online / Offline .....	44
Exiting the Intellispec software.....	44
<b>Chapter 6 User Accounts and Login Information.....</b>	<b>47</b>
Logging in and logging out .....	47
Log in menu.....	47
Switching users .....	48
Changing your password.....	48
Managing user accounts .....	49
Exporting user accounts.....	51

Importing user accounts .....	52
Managing Permissions .....	53
Setting up Auto Logout .....	57
<b>Chapter 7 Graphs and Image Displays .....</b>	<b>59</b>
Walk By Graphic.....	59
Trend Graphs .....	62
Reject Images.....	65
Machine Part Graphs .....	67
Timing Trend .....	68
Inspections graph.....	68
Statistics Grid .....	69
Big Live Image .....	72
<b>Chapter 8 Alarms .....</b>	<b>73</b>
Viewing and Clearing Alarms .....	74
System Alarms Description .....	76
Lane Alarm Configuration .....	76
Lane Alarms Description .....	79
Sensor Alarm Configuration.....	80
Sensor Alarms Description.....	83
<b>Chapter 9 Tools Menus.....</b>	<b>85</b>
Tools menu - System Overview Screen.....	85
Tools menu - Lane Overview and Sensor Overview Screens .....	86
<b>Chapter 10 Software Utilities.....</b>	<b>123</b>
Go Online at Startup .....	123
Adjusting Date and Time.....	123
Setting up a printer .....	124
Creating a Support Package .....	124
Help - Remote Support .....	127
Discovery Software - What is Discovery?.....	129
Favorites Menu .....	131
<b>Chapter 11 Lighting and Imaging.....</b>	<b>135</b>
Sensor menu .....	135
Saving Images .....	150
Loading Saved Images.....	163
Image Options.....	165
<b>Chapter 12 Inspection Overview .....</b>	<b>167</b>
Inspection Terminology .....	167
Sequence of Events During Inspection .....	168
Part Tracking .....	168
How to Create, Copy, or Import a Part Program.....	169
Part Changeover .....	171
Inspection menu .....	172
Inspection Tree Relationships .....	178
Adding Regions and Inspections .....	179
Region Editor.....	180

Inspection Editor .....	181
Retro-Spec Population View Graph .....	185
Retro-Spec Part View Graph .....	188
<b>Chapter 13 Inspections .....</b>	<b>191</b>
Empty Pocket .....	191
Regions of Interest (ROI) .....	192
Enhancements .....	203
Registrations .....	215
Orientations .....	244
Analyses .....	251
Dimensions .....	287
Correlation .....	293
<b>Chapter 14 System Hardware Information .....</b>	<b>295</b>
Power Up .....	295
Power Down.....	295
Servicing the User Interface.....	295
Wiring Diagrams.....	296
Rebooting the Intellispec System.....	300
Light Tree .....	302
<b>Chapter 15 Inspection Modules .....</b>	<b>305</b>
Observe Part Image .....	305
Extended I/O in inspection modules.....	306
CP/E Series modules .....	307
CP4422EV inspection module .....	321
CP500 inspection module .....	330
CPX inspection module .....	333
<b>Chapter 16 Extended I/O .....</b>	<b>337</b>
Extended I/O board.....	337
Extended I/O in inspection modules.....	344
Extended I/O Configuration .....	344
<b>Chapter 17 Maintenance Frequency .....</b>	<b>349</b>
Cleaning the User Interface Enclosure filter .....	350
Replacing/ Cleaning the Chromapulse CP4422EV Fan Filters .....	351
Cleaning Optical Surfaces.....	351
Cleaning Glass Surfaces.....	352
Cleaning the Chromapulse Beam Splitter .....	352
Cleaning the Camera Lens.....	353
Cleaning Plastic Surfaces.....	353
Cleaning the Ellipsoidal Mirror.....	354
Cleaning the Part Detector .....	355
Cleaning the Part Detector and Reflector .....	355
Replacing Filter/ Regulator Filters.....	356
<b>Chapter 18 About OPC.....</b>	<b>357</b>
The Intellispec OPC Server .....	357
OPC Configuration .....	358

The Intellispec OPC test client .....	359
List of Data Items .....	370
References .....	372
<b>Chapter 19 How to Contact Pressco .....</b>	<b>373</b>
<b>Index .....</b>	<b>375</b>

# Chapter 1

## Introduction

---

### Welcome!

Congratulations on your purchase of an Intellispec system! The Intellispec is a high-speed machine vision system designed specifically for product and online process monitoring. It is a very powerful tool that provides inspection much more reliably than the human eye or sampling methods. The latest PC technology, powerful new inspection algorithms, online adjustment capability, and inspection data storage allow the Intellispec to automatically inspect parts with extreme accuracy on high-speed lines. The Intellispec will help you provide the highest quality of products shipped to your customers.

---

### About the Intellispec Series V Compact Single Lane (CSL) System

The Intellispec CSL system performs high-speed vision inspection of parts, like the standard Intellispec Series V system.

The following is a summary of how the Intellispec Series V CSL system differs from the standard Intellispec Series V system.

➤ ***The Intellispec Series V CSL system DOES:***

- Support one lane of inspection, supporting up to three cameras (as opposed to up to eight lanes on a standard system). Note: Some camera configurations require extra hardware.
- Support Intellispec Series V E<sup>2</sup> tunnels.
- Support all cameras currently supported by Intellispec Series V standard systems.
- Support the following applications:
  - Lined shell
  - Food ends
  - EZO ends
  - Three piece cans
  - Two piece cans
  - Twist closures
  - Crowns
- Support touch screen or non-touch screen options.
- Support wall mount or pole mount options.
- Support the biometric reader option.
- Support plant networking.

➤ ***The Intellispec Series V CSL system does NOT:***

- Have a pedestal for the computer and user interface.
- Support the Defect Database option.
- Support the remote user interface.
- Support cluster boxes.

---

## About this manual

This manual:

- Is considered to be valid as of release 5.0.501 of the Intellispec Series V software. Contents of this manual are subject to change without notice.
- Is considered an integral part of the system and should be kept handy for future reference as long as the system is being used in your plant.
- Is your responsibility to keep in good condition, in a dry place, and ready for consultation by the **authorized users** (on page 16) of the system.
- Contains the technology implemented at the time of selling and supplying the system and shall not be considered inadequate in case of technological enhancements in the machine or in the manual's illustrations.

Related books include:

- Intellispec Series V Operator's Guide which has Operator-level user instructions, and is a good place to start if you are new to Intellispec

---

## Typographical Conventions

Following is a list of typographical conventions used in this manual:

- **Bold type** indicates a topic heading or an important item or statement.
- *Italicized type* indicates emphasis.
- Names of main components and system control signals have the first letter of each word capitalized. For example: Processor Cabinet.
- Danger messages appear as shown below:



### **Danger**

Danger messages alert you to specific conditions that can cause serious or fatal personal injury. Danger messages give you important information which must be observed to prevent injury. These messages are set off from the body text as shown here.

- Caution messages appear as shown below:



### **Caution**

Caution messages indicate important information which must be observed to prevent: loss of data, poor system performance, or equipment damage. These messages are set off from the body text as shown here.

- Notes appear as shown below:

❖ *Note: Notes contain special information that warrants being set off from the body text as shown here.*

---

## Safety Considerations

Observe the following safety warnings when operating the system or working near it:



### Warning

Potential for projectiles to strike persons and cause injury. Keep clear of reject devices.



### Warning

Sensitive electronics and High Voltages may be exposed. Keep Processor Cabinet door closed.

---

## Static Discharge Protection



### Caution

Electronic components can be damaged by static electricity discharge.

Always observe the following precautions before removing, installing or handling any electronic components within the Inspection System:

- Wear an anti-static wristband which is grounded to the Inspection System.
- Stand on an anti-static, grounded floor mat, and lay circuit boards on the mat during any board replacement.
- Keep circuit boards in static shield bags when storing and transporting. Ensure the bag is sealed.



# Chapter 2

## Safety Information

This section contains operator safety information that must be read before operating or servicing the system.



### Warning

Do not, under any circumstances, tamper with sealed machine parts or devices. This could result in the removal of protections that might create potentially hazardous conditions.



### Warning

This product contains no operator serviceable parts. Refer servicing to qualified personnel. To prevent electrical shock do not open cabinet doors whilst power is connected.

## Symbols

The following symbols are used on or near the Intellispec system. Be aware of potential risk hazards.

	CAUTION Risk of danger. Refer to accompanying user documentation before use.
	WARNING Risk of electric shock
	On (supply)
	Off (supply)
	Alternating current
	Protective conductor terminal

## Marking

The following illustration shows an example label that you will find on the Intellispec Series V system components.

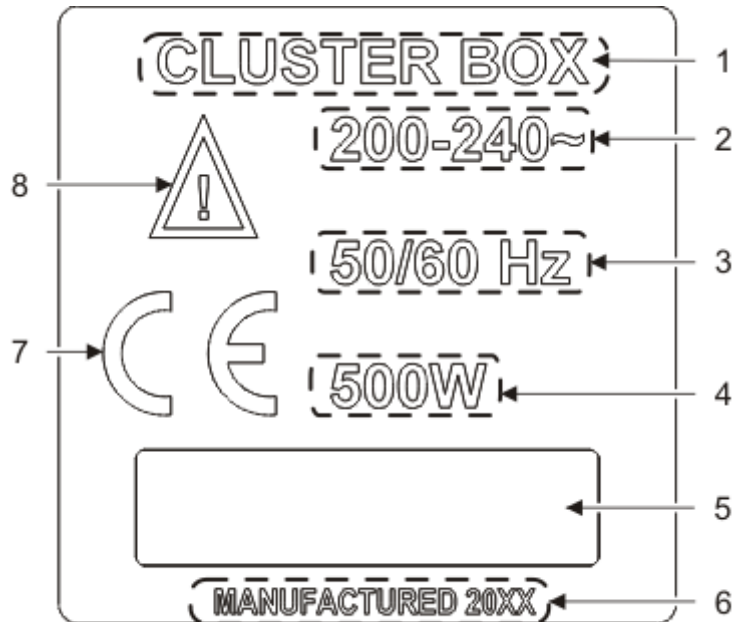

1	Name of component. NOTE: Chromapulse model is listed on the front panel of the module. See example below.
2	Voltage range in Volts AC
3	Frequency range in Hertz (Hz)
4	Maximum rated power in watts (W) with all accessories or plug-in modules connected
5	Serial number is listed in this box
6	Year of manufacture
7	Component certification
8	Risk of danger. Refer to accompanying documentation before use.

An example of a Chromapulse module label with the model number is shown below.

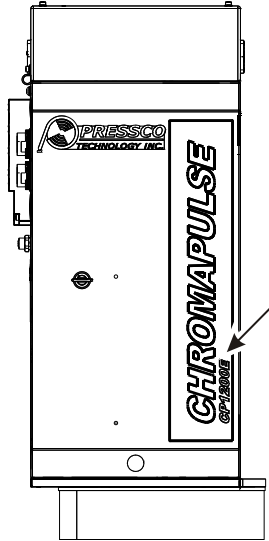

For additional markings, see the System Specifications section.

---

## Warning Devices

The Intellispec Series V system has warning devices that indicate system failure or report excessive defects or warnings for your production line.

### Alarms

User-programmable **alarms** (on page 73) allow you to set the duration of the lights in the optional light tree and the horn if certain criteria are met.

In addition to the light tree, an alarm button is displayed on screen when certain criteria are met. You can click the alarm button to **clear the alarm** (see "**Viewing and Clearing Alarms**" on page 74)(s) and see more detailed information about the alarm condition.



### Light Tree

The optional light tree may be mounted on or near an inspection module, or near a cluster box (if applicable). The optional horn, mounted with the light tree provides an audible warning.

For more information, refer to **Light tree status** (on page 302).



Light Tree (optional)

- Red (Alarm)
- Amber (Warning)
- Green (Online)
- Blue (Power)

---

## Residual Risk

The Intellispec system has been designed to minimize any danger of personal injury. However, the system uses rejection devices to remove defective product from the production stream. Also, the electronics cabinets contain risk of shock if they are opened.

Observe the following safety warnings when operating the system or working near it:



### **Warning**

Potential for projectiles to strike persons and cause injury. Keep clear of reject devices.



### **Warning**

Sensitive electronics and High Voltages may be exposed. Keep Processor Cabinet door closed.

---

## Intended Use

### ***Type of Process***

The Intellispec system is intended to monitor container and other special manufacturing processes and identify non-conforming product.

### ***Intended Use***

The Intellispec system is designed and constructed for use in an indoor industrial environment, always sheltered from the weather.

### ***Space Required***

The Intellispec machine and accompanying sensors must be installed in a place that will enable safe and easy installation, size changeover, user operation, and maintenance procedures.

---

## Non-intended use



### Warning

If this instrument is not used as specified, the protection provided by the equipment could be impaired. This instrument must only be used in a normal condition (in which all means of protection are intact).



### Important

The Intellispec system should NOT be used for any purpose other than specifically indicated in the section titled *Intended Use* (on page 12).

The following uses are **not** intended:

- Use in an explosive environment
- Use in a flammable environment
- Use in a damp, moist, or wet environment, except where specifically indicated

---





## Personal Protective Equipment



### Important

Always follow the safety requirements of your plant in addition to the recommendations below.





We recommend, at minimum, use of the following Personal Protective Equipment (PPE):

	Protective clothing
	Protective gloves
	Protective ear plugs or headphones
	Protective eye wear
	Protective foot wear





# Personnel Safety

The following rules are recommended to ensure the safety of personnel in charge of machine operation and maintenance.

## *During machine operation:*

	Only one operator is needed to operate the machine. All others must keep at a safe distance.
	Operators must be familiar with all machinery connected to the Pressco equipment and know how to use emergency stop devices. Note: the emergency stop devices may not be connected directly to the Pressco equipment, but it is important to know how to use them.
	Before putting the Pressco system online, the operator must ensure that all safety devices used with all connected machinery are in place and operational.
	The operator must maintain maximum focus on his work and be alert throughout his shift. If this is not the case, immediately inform the shift supervisor.

## *When carrying out maintenance or repair work:*

	Disconnect master switch. For switch locations, refer to the <b>Power Up</b> (on page 295) and Power Down section.
	Before starting the machine, ensure that no person is close to the machine.
	If maintenance or repair requires the disconnection or removal of safety or protection systems, this operation must be supervised by authorized personnel who must ensure the prevention of personal injury or damage to the machine. All machine movements must be performed with limited speed and limited movements.
	Maintenance or repair work on electrical components must be carried out exclusively by authorized, trained personnel. When running tests with power connected, you must strictly comply with the rules provided.
	Personnel working on higher parts of a machine must wear a harness and hook it on to the structure and must always move with extreme caution.



Never perform lubrication or maintenance procedures on mechanical parts with the machine running.



### ***For your safety, do not:***

- Open safety guards during machine operation
- Perform maintenance and repair while the system is running
- Lean on the machine
- Sit on the machine components
- Use the machine for purposes other than those listed in this manual
- Modify parts of the machine
- Allow unqualified personnel to operate or perform maintenance procedures on the machine

---

## **Lifting heavy objects**



### **Caution**

Some components are heavy. Take proper precautions to prevent personal injury or damage to equipment. If you are not capable of lifting the object alone, ask a capable person to help lift the object, or use a mechanical lifting device

The components do not have handles to lift the equipment. Be sure to:

- Lift equipment from the bottom - do not use wires, brackets, nor other protrusions
- Keep fingers away from sensor lenses to keep the equipment clean
- Proceed slowly

### ***➤ To safely lift equipment:***



### **Caution**

Do not twist your body when moving the load. Instead take small steps with your feet turning until you are in the correct position.

1. Stand close to the load and center yourself over it with your feet shoulder width apart.
2. Tighten your abdominal muscles.
3. Keeping your back straight, bend your knees and squat down to the floor.
4. Get a good grasp on the load with both hands.
5. Keeping the load close to your body, use your leg muscles to stand up lifting the load off the floor.
  - Your back should remain straight throughout lifting, using only the muscles in the legs to lift the load.
6. To place the load in the appropriate spot, bend at the knees using only your leg muscles to lower the load.

---

## Authorized Users

Trained machine operators, mechanic and electrical maintenance staff, and plant managers are considered authorized users of the Intellispec system. These users should carefully read the information contained in this manual. The plant manager must ensure that the safety recommendations included in this manual are observed.



### Warning

Allowing workers who are unfamiliar with the production process to operate the Intellispec system could result in hazard risk.

If you are unclear about any part of this manual, **contact Pressco Technical Support** (see "**How to Contact Pressco**" on page 373).



### Important

No worker should ever operate the system outside of his/ her own area of competence and responsibility.

### **Proper Operation:**

Only one worker is to operate the system at any given time. The correct position for the operator is in front of the user interface monitor or control enclosure (if applicable).

### **Repairs:**

Any repair on the system shall be carried out exclusively by Pressco Technology Inc. service personnel or by other service expressly authorized by Pressco Technology Inc.

---

## Spare Parts Usage

The following restrictions apply to replacing parts:



### Warning

Using spare parts that are not designed to Pressco's specifications can compromise the safety and effectiveness of the Intellispec system.

- The use of parts that are not within Pressco's design specifications is prohibited. This prohibition applies in particular when the parts involved contain or are connected with safety devices.
- Before resuming production, make sure all safety devices are in working order.

Pressco Technology Inc. shall not be liable in any way if any of the above-described directions are not complied with.

To obtain a spare parts list, contact the customer service department at Pressco. **How to Contact Pressco** (on page 373).

Pressco's technicians are available to help customers, in their own plant, to solve any problem that might arise during use and maintenance of the Intellispec system.

# Chapter 3

## System Specifications

This instrument has been designed and tested in accordance with Publication EN61010-1:2010 Safety Requirements for Electrical Equipment for Measurement, Control and Laboratory Use and has been supplied in a safe condition. The instruction documentation contains information and warnings which must be followed by the user to ensure safe operation and to maintain the instrument in a safe condition.

### Environmental conditions

The Intellispec Series V system is designed to be safe in the following environmental conditions:

❖ *Note: Please consult Pressco Technology Inc. (see "How to Contact Pressco" on page 373) if your environmental conditions are outside of those listed.*

Condition	Specifications
Indoor/ outdoor use	Indoor use only
Altitude	Up to 2000 meters
Operating Temperature	5 °C to 50 °C
Storage Temperature	0 °C to 70 °C
Humidity	Maximum relative humidity 80 % for temperatures up to 31 °C decreasing linearly to 50 % relative humidity at 50 °C
Mains supply	Voltage fluctuations up to $\pm 10$ % of the nominal voltage
Overvoltage protection rating	Transient overvoltage typically present on MAINS supply NOTE: the normal level of transient overvoltages is impulse withstand (overvoltage) category II of IEC 60364-4-443.
Rated pollution degree	This instrument is designed for use in Installation Category II and Pollution Degree 1 as per EN61010-1 and EN60664 respectively.



#### Warning

This is a Class A product. In a domestic environment this product may cause radio interference in which case the user may be required to take adequate measures.

### Sound Pressure Level

The horn on the optional **light tree** (on page 11) has a maximum 105dB level at 1 meter distance in front of the horn. Use proper hearing protection as specified by your plant safety instructions.

---

# Specifications

The following sections contain electrical specifications and measurements for components of the Intellispec Series V system. Your system contains only the components necessary for your application.

## User Interface

### *CSL User Interface Electrical Specifications*

The following are electrical specifications for different configurations of the User Interface:

<b>User Interface with 500VA UPS, 120VAC</b>	
Voltage Range	100-132VAC
Nominal Voltage	120VAC
UPS Input Current	5.6A @ max load
UPS Output Power (max)	300W
Frequency	50/60Hz

<b>User Interface with 500VA UPS, 230VAC</b>	
Voltage Range	200-240VAC
Nominal Voltage	230VAC
UPS Input Current	2.4A @ max load
UPS Output Power (max)	300W
Frequency	50/60Hz



### **Caution**

Before connecting this system to the mains power supply, ensure that the supply voltage is within the specified range.

## CSL User Interface dimensions

The following are the dimensions of the Intellispec Series V CSL User Interface (see illustration below):

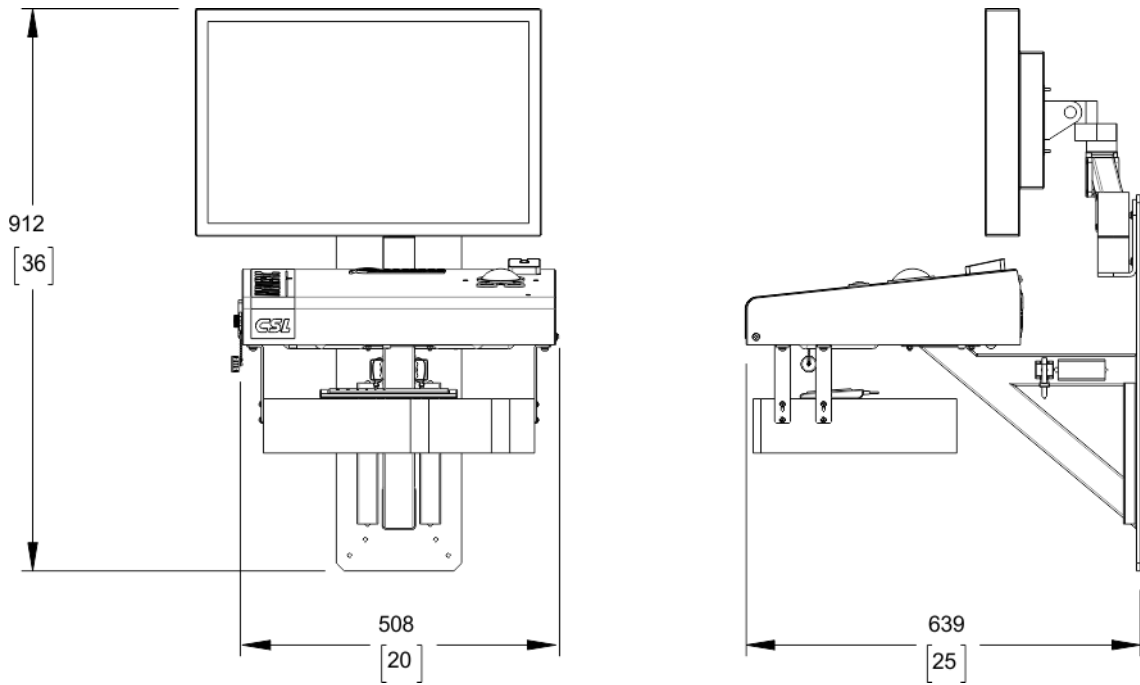

Measurement	Value
Height	912 mm [36 in]
Width	508 mm [20 in]
Depth	639 mm [25 in]

## CSL User Interface weights

The following are the weights of the Intellispec Series V CSL User Interface (see illustration below):

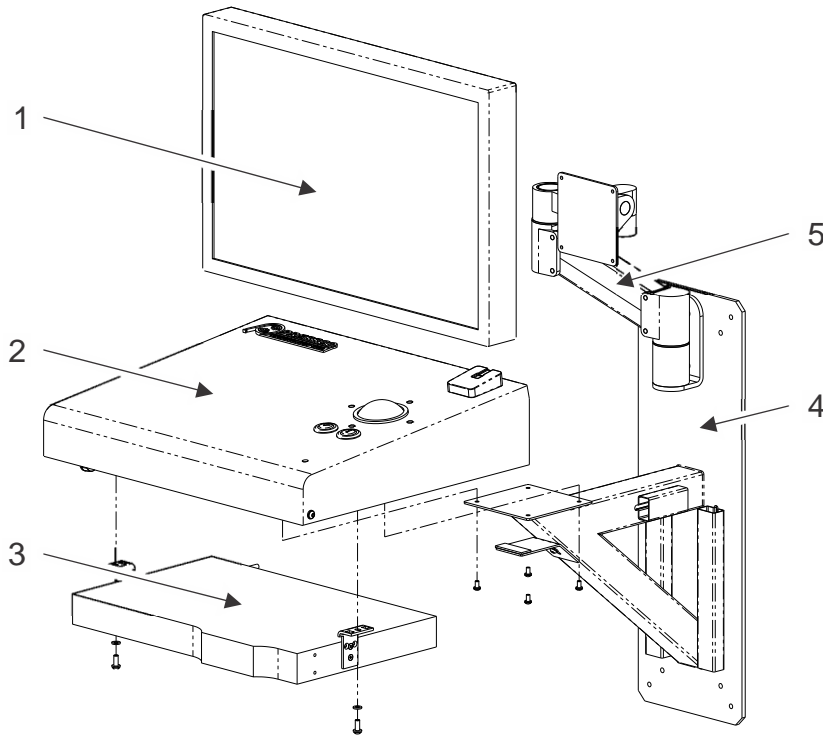

item	Description	Weight
1	Monitor	11.3 Kg [25 lb]
2	User Interface	18.6 Kg [41 lb]
3	UPS	9.5 Kg [21 lb]
4	Weldment	8.2 Kg [18 lb]
5	Monitor Arm	4.5 Kg [10 lb]
	Total User Interface	52.2 Kg [115 lb]



### Caution

This object is heavy. Review the section on *lifting heavy objects* (on page 15) before moving this object.

## Integrated Tunnel Electrical Specifications

The following are electrical specifications for the integrated tunnel (an inspection module that contains cameras and part tracking in one unit, such as the CP/ EV series tunnels).

Standard - No UPS	
Voltage Range	100-240VAC
Frequency	50/60Hz
Current	6.2A @ 120VAC, 100% Load

<b>Optional 500VA UPS, 120VAC Nominal</b>	
Voltage Range	100-132VAC
Frequency	50/60Hz
Current	4.1 @ 120VAC, 100% Load

<b>Optional 500VA UPS, 230VAC Nominal</b>	
Voltage Range	200-240VAC
Frequency	50/60Hz
Current	2.2A @ 230VAC, 100% Load

### ***CP/EV module measurements***

The following are the weights and dimensions of the CPxx/ EV series inspection modules:

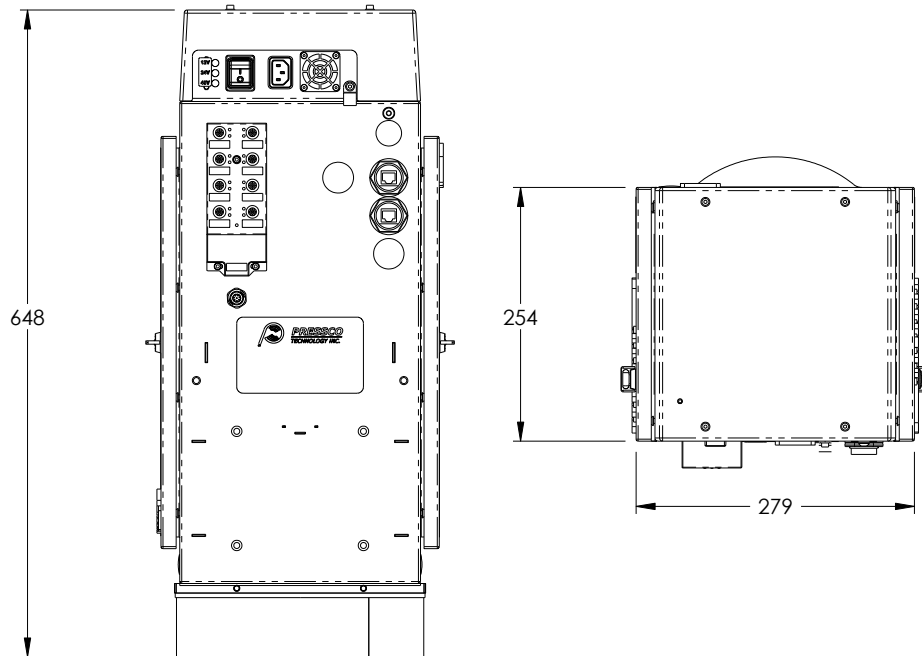

<b>Measurement</b>	<b>Value</b>
Weight	16.4 Kg [36 lb]
Height	648 mm
Width	254 mm
Depth	279 mm

❖ *Note: measurements do not include connectors*



### **Caution**

This object is heavy. Review the section on *lifting heavy objects* (on page 15) before moving this object.

---

# Declaration of Conformity - Intellispec™ CSL System



**Number:** CE3371

**Declaration:** The Pressco Technology, Inc. Compact Single Lane System is in conformity with Directive 2004/108/EC of the European Parliament and of the Council of 15 December 2004 on the approximation of the laws of the Member States relating to electromagnetic compatibility and repealing Directive 89/336/EEC, and with Directive 2006/95/EC of the European Parliament and of the Council of 12 December 2006 on the harmonization of the laws of Member States relating to electrical equipment designed for use within certain voltage limits.

**Manufacturer:** Pressco Technology, Inc. of 29200 Aurora Road, Cleveland, Ohio USA 44139-1847.

Machine description: AUTOMATED MACHINE VISION INSPECTION SYSTEM

Make: Pressco Technology Inc.

Model Number: INTELLISPEC™ Compact Single Lane (CSL)

Serial Number: All above B2280

Standards Used (only major standards listed):

EN 61326-1:2006 Electrical equipment for measurement, control and laboratory use —EMC requirements

Part 1: General requirements

EN61010-1 (2010) Safety requirements for electrical equipment for measurement, control and laboratory use

Part 1: General requirements

A technical construction file (TF3371) for this product is retained at the above address.

Signed: Date: 11 January 2012

Name: **Noel E. Morgan Jr.** Title: **VP of Research and Development**

Being the person authorized by the manufacturer to sign on their behalf.

---

# Declaration of Conformity - Integrated Tunnel



**Number:** EMC2932

**Declaration:** The Pressco Technology, Inc. Intellispec Series V Inspection System is in conformity with Directive 2004/108/EC of the European Parliament and of the Council of 15 December 2004 on the approximation of the laws of the Member States relating to electromagnetic compatibility and repealing Directive 89/336/EEC, and with Directive 2006/95/EC of the European Parliament and of the Council of 12 December 2006 on the harmonization of the laws of Member States relating to electrical equipment designed for use within certain voltage limits.

**Manufacturer:** Pressco Technology, Inc.  
29200 Aurora Road  
Cleveland, Ohio 44139-1847  
USA

**Product Identification:** Product Name: Intellispec Series V Inspection System

**Standards Used** (only major standards listed):

- **EN 61326-1:2006:** Electrical equipment for measurement, control and laboratory use — EMC requirements — Part 1: General requirements
- **EN61010-1 (2001):** Safety requirements for electrical equipment for measurement, control and laboratory use - Part 1: General requirements

**Technical File:** MS2932

**Place:** Pressco Technology, Inc.  
29200 Aurora Rd.  
Solon, Ohio 44139-1847  
USA

April 30, 2010

Signed:

Date:

Name: **Noel E. Morgan Jr.**

Title: **VP of Operation**

Being the person authorized by the manufacturer to sign on their behalf.

# Chapter 4

## Installation and Wiring

### Shipping and Handling

Pressco Technology Inc. ships unassembled components in packing cases designed to protect the contents during handling and from exposure to weather.

Unless otherwise specified in the contract with the machine order, the Customer shall supply Pressco Technology Inc. with the means and equipment necessary for the unloading, lifting, and handling of machine parts. Pressco Technology Inc. deems it important to have one of their technicians supervise the process of unloading, handling, and lifting the machine. The technician can give useful advice as to the logical sequence in which the components should be unpacked and positioned for ease of assembly.



#### Warning

Only qualified personnel must be involved in the operation of unloading, handling, and lifting the machine. Pressco Technology Inc. shall not be liable for damage to components and/or personal injury resulting from the involvement of unauthorized personnel and/or failure to comply with the directions provided in this manual in relation to lifting and transport.



#### Important

The site supervisor will be responsible for ensuring that all the various mounting phases are carried out safely and in compliance with current regulations.

After the machine is delivered, check for any damage that might have occurred during shipping. In case of damage, contact **Pressco Technology Inc** (see "**How to Contact Pressco**" on page 373).

In handling the machine, always keep it close to the ground.



We recommend using a forklift truck with adequate capacity and forks to suit the weight to be lifted (machine plus packaging).

The dimensions and weight of a crate are listed below. Note that this is the maximum size and weight. The size and weight of the crate may be less depending on your configuration. You may receive multiple crates depending on your configuration.

<b>Size</b>	1143 cm x 889 cm x 1244.6 cm ( 45 x 35 x 49 inches)
<b>Weight</b>	204.12 kg (450 lbs.)

---

## Recommendations prior to installation

Before the machine is installed, the Pressco installer, together with the Customer (or representative) shall check the following criteria in the environment where the machine is to be installed:

- Work required by contract for the installation of the machine has been carried out
- The plant layout drawing that describes where the machine will be installed is the final drawing agreed to by Pressco Technology Inc.
- The space and height required for installation are actually available
- Only the components included in the installation layout are present in the area where the machine is to be mounted. Ensure no machines or components have been added at a later stage that might hinder mounting or make it more difficult. Should this be the case, immediately contact Pressco's Project Engineering personnel to arrange a suitable solution to the problem.

We recommend the following prior to machine installation:

- Transport the machine in its packaging to the area where it will be installed to minimize possibility of damage
- Carefully remove the packaging material and check components for damage
- Check tightness of mechanical components, as they can loosen during transport
- Prepare the compressed air mains line. Before making final connections, ensure that the pipes are clean and free from any debris.

# System Block Diagram - CSL

Below is a basic block diagram for Series V Intellispec. This drawing shows the major components for the system. Your system will contain only the components required for your application. The numbered components are listed in the table below.

The drawing below shows a basic block diagram for a system with an integrated tunnel (with one camera).

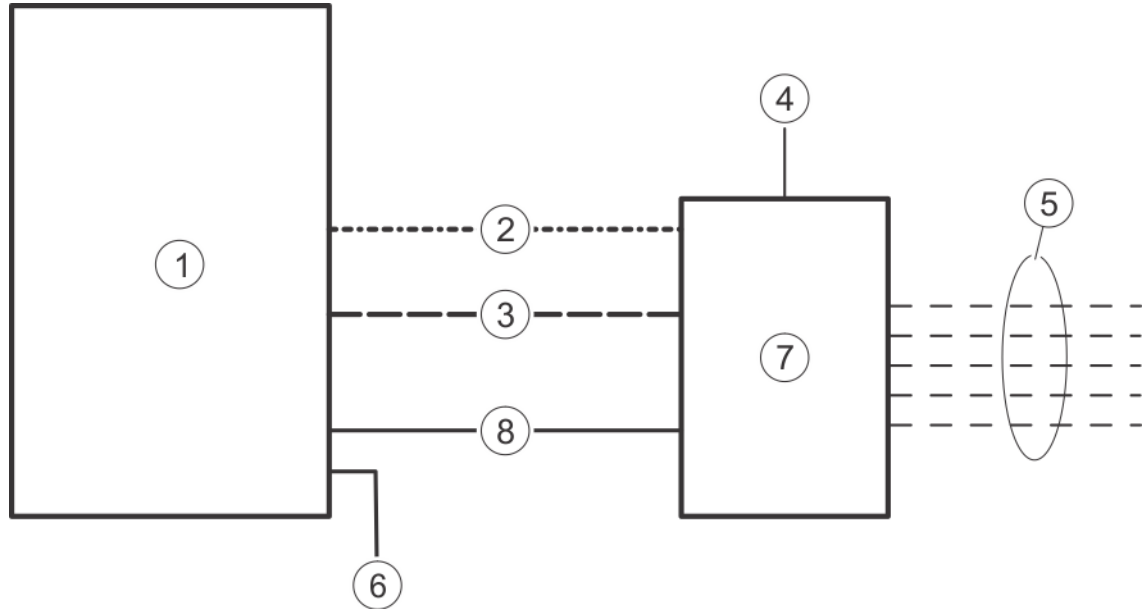

1	User Interface (PC, monitor, and UPS)
2	PDN (Pressco Data Network) ethernet green cable
3	Inspection sensor/ camera ethernet blue cable
4	Light tree (optional)
5	Sensor cables (for part present sensor, encoder, machine part, pocket detect, reject confirm) For details: <i>I/O connectors</i> (see " <i>Chromapulse module external connections</i> " on page 315)
6	AC power in
7	Integrated tunnel (example: CP/EV inspection module)
8	AC power from user interface to tunnel (source of power is UPS)

## Assembly, location, and mounting requirements

The Intellispec requires the following:

### Utilities to be supplied by customer

The following utilities are required to operate the Intellispec Series V system. Before making connection, make sure the utility matches the technical specifications. More than one connection of the utilities may be required depending on the number of modules installed. Refer to specific wiring diagrams.

Utility	Requirements
Air supply for rejection device	Pipe size must be such that there will be no pressure decrease during machine operation. Air must be dry and free of oil.
Electrical supply	Provide one each electrical socket to comply with: <ul style="list-style-type: none"> <li>▪ <b>User interface electrical specifications</b> (see "<i>CSL User Interface Electrical Specifications</i>" on page 18) (use the specifications that apply to your system)</li> <li>▪ <b>Integrated tunnel electrical specifications</b> (on page 20) (if applicable)</li> <li>▪ Cluster box electrical specifications (if applicable)</li> </ul>
Internet connection (optional)	Provide a shielded ethernet cable to use Pressco's remote support through the Internet.

## Protective earthing

This product must be grounded (earthed). If it should malfunction or break down, grounding provides a path of least resistance for electric current to reduce the risk of electric shock.



### Danger

Improper connection of the equipment grounding conductor can result in a risk of electric shock. Check with a qualified electrician or service technician if you are in doubt as to whether the product is properly grounded.

## Cord Connected Equipment

The product will be equipped with a supply cord having an equipment grounding conductor and a grounding plug. The plug must be plugged into an appropriate outlet that is properly installed and grounded in accordance with local codes and ordinances.

The UPS chassis provides a protective earth ground lug on the back panel. Use this ground lug to connect any equipment that requires a chassis ground.



### Caution

Do not modify the plug provided with the product - if it will not fit the outlet, have a proper outlet installed by a qualified electrician.



### Caution

Do not replace detachable mains supply cords with inadequately rated cords. Only use properly rated cords.

## Cable Direct

This product must be connected to a grounded metal, permanent wiring system, or an equipment grounding conductor must be run with the circuit conductors and be connected to the equipment grounding terminal.

## Electrical connection

Make sure that the power outlet voltage matches the voltage required by the machine. Refer to the specifications for equipment included with your system:

- **CSL User Interface Electrical Specifications** (on page 18)
- **Integrated tunnel electrical specifications** (on page 20)



### Warning

Due to the presence of an uninterruptible power supply, appliance couplers (power cords) are the power disconnect device. Do not position the equipment such that access to the couplers is impaired. If not readily accessible (such as within a rack or mounting out of reach), an additional disconnect device should be installed that can isolate the Live and Neutral lines of the mains power supply, while leaving the protective earth intact.

To isolate the Compact Single Lane System from the power supply, ALL couplers identified below **MUST** be disconnected.

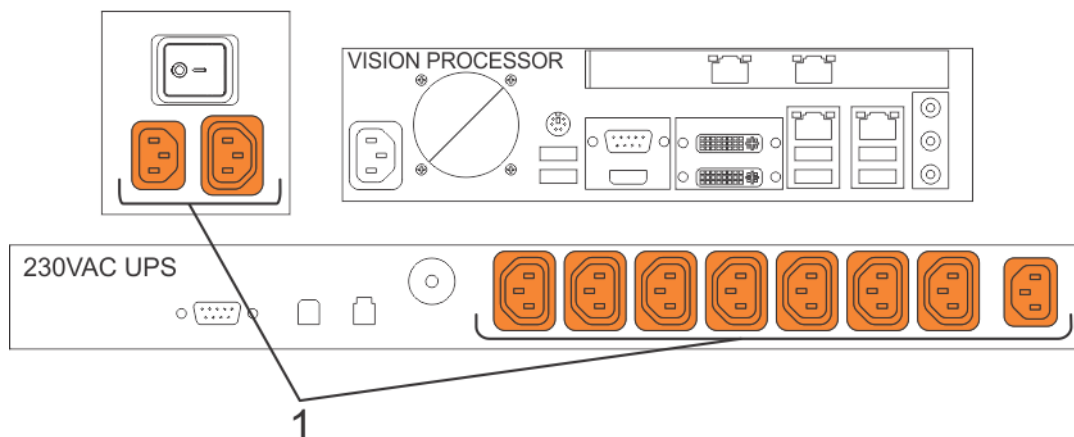
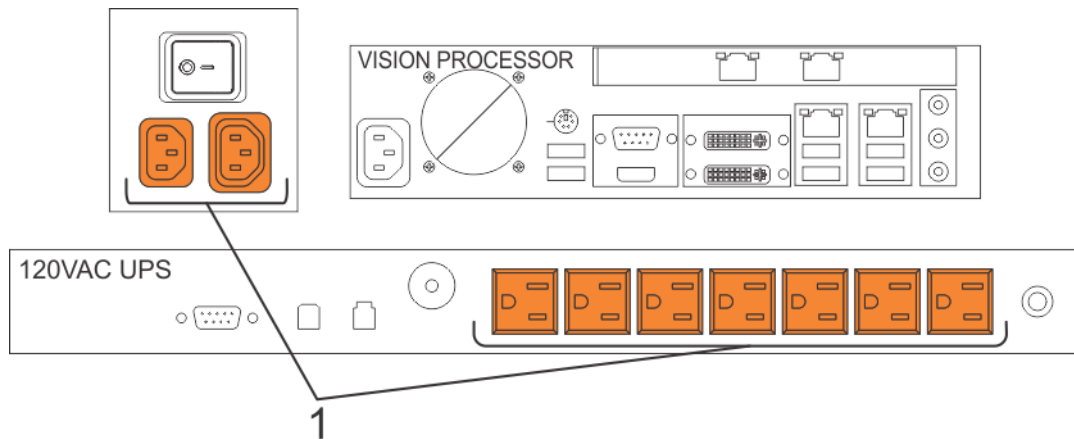

1	To remove power from the system, disconnect power cords from ALL highlighted outlets
---	--

## Installation

Pressco Technology Inc. recommends that the machine be installed and assembled by Pressco's specialized technicians. This is of vital importance for correct machine operation.



### Warning

Pressco Technology Inc. shall not be liable in case of failures or damage to property and/or personal injury resulting from or connected with assembly if this has been carried out by unauthorized personnel, or is not in compliance with the indications given in this manual.

To carry out production and cleaning/ servicing operations, it is important for the machine to have a minimum amount of space all around and away from walls.

### Ventilation

Place the Intellispec Series V components in a position with adequate ventilation to allow proper air flow through the air filters.

Component	Spacing
User Interface	Leave 1 meter [39 inches] clear around machine
Cluster box (not used on all systems)	Leave 100 mm clear in front of the fan and vent

---

## Commissioning

Before placing the machine into operation, make sure the following checks are completed:

Completed	Yes	No
Positioning and leveling of the unit		
Connection of compressed air line to connection points		
Connection of power supply to user interface cabinet		
Connection of power supply to cluster box (if applicable)		
Connection of power supply to integrated inspection module(s) if applicable		
Proper wiring from user interface cabinet to sensor module(s) and cluster box (if applicable) using the wiring diagrams		

# Chapter 5

## Navigating Through the System

This section describes the regions of the user interface and how to navigate through the software. It also describes how to select items and how to use the user interface buttons.

### Intellispec CSL cabinet and user interface

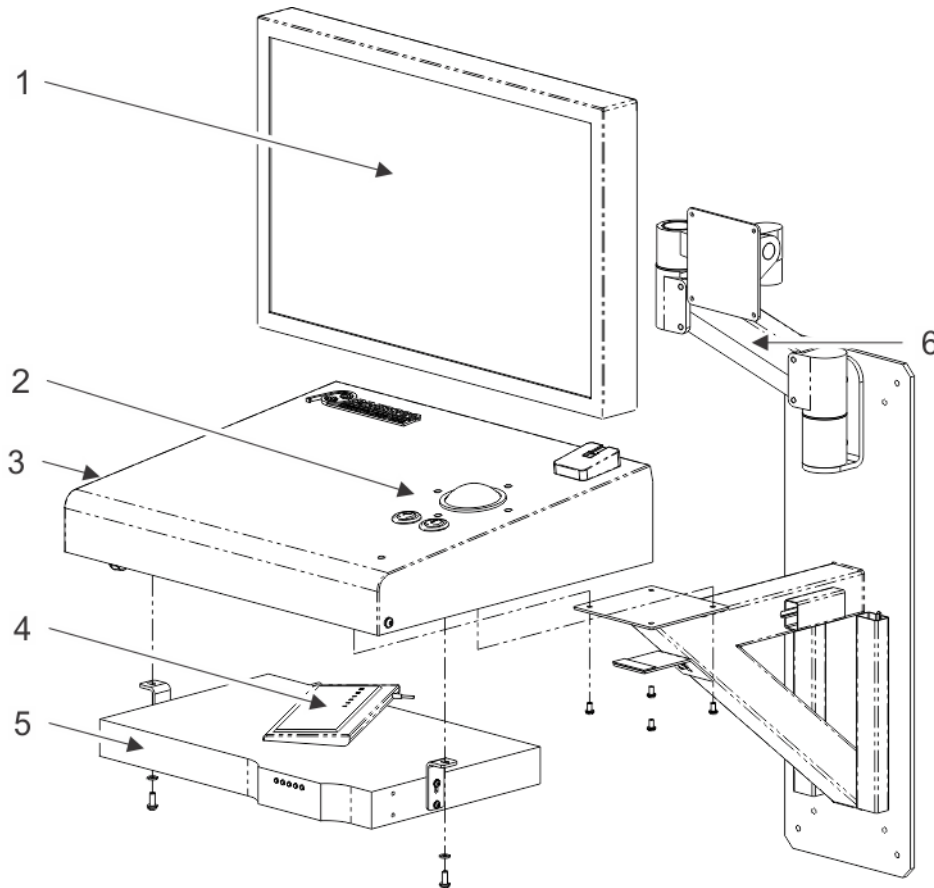

1	24" Diagonal color LCD with optional touch screen. An on-screen keyboard (OSK) is displayed when needed.
2	Trackball with two buttons: Select button [ ✓ ] Information and right-click button [ i ]
3	USB convenience port is mounted on the side of the user interface.
4	Mechanical keyboard (MKB) for administrative tasks
5	UPS (Uninterruptible Power Supply)
6	Mounting arm

## Monitor

The standard monitor is an LCD color monitor mounted on a mechanical arm to allow the user to tilt or swivel the screen for best viewing. It has an area of 1920 x 1200 pixels and a diagonal size of about 24 inches.

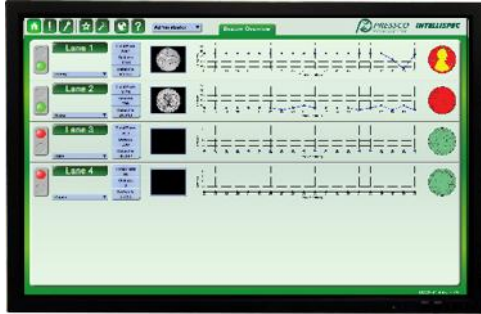

## Touch Screen Monitor (optional)

Some Intellispec systems have a touch screen monitor installed. It has an area of 1920 x 1200 pixels and a diagonal size of about 24 inches. This is used primarily for high level navigation, obtaining information from the system, and responding to alarms. It is not to be used for inspection setup or configuration tasks, as those tasks require detailed input.

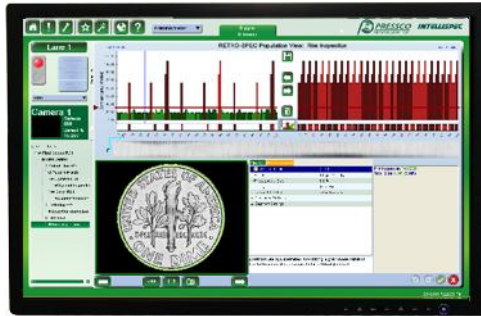

Use the touch screen to:

- Log in / out
- Put the system online / offline
- Clear statistics
- Print reports
- Acknowledge or reset Alarms
- Navigate the menus (from System Overview to Lane View to Sensor view, etc.)

---

## User interface input devices

The following devices are available to input information to the Intellispec system:

- **Trackball and buttons** (see "**How to select menu items**" on page 33)
- **On Screen Keyboard (OSK)** (on page 34)
- **Touch Screen monitor (optional)** (on page 32)
- Temporarily connected conventional **Mechanical Keyboard (MKB)** (on page 35)
- **USB Ports** (on page 35)
- Optional Biometric Identification login **device** (see "**Biometric login device**" on page 36)

## CSL User interface selection devices

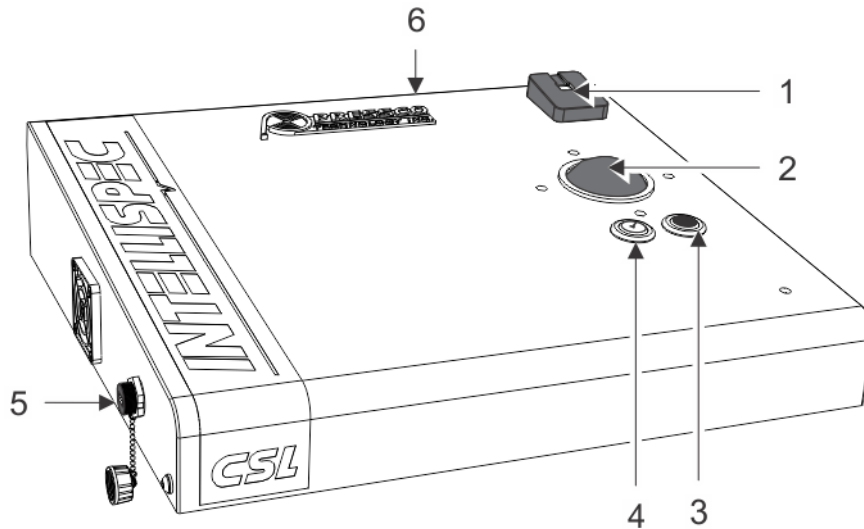

The user interface hardware consists of several buttons and selection devices:



1	Optional Biometric Identification login device
2	Track Ball
3	Button (right-click) to call up a context-sensitive menu about the selected object on screen
4	Button (left-click) to select and activate objects on screen
5	USB convenience port
6	AC power switch located on the back of the unit

## How to select menu items

Use the track ball to select, interact, and change active objects on the screen. The track ball will be required for all inspection editing tasks.

Under the track ball are two buttons. Use the left button (the primary button ) to select and activate objects on the screen. Use the right button  to call up a context-sensitive menu related to the area or object clicked. A second set of each button type is located on the left side of the podium for two-handed operation.

**Note:** *Swapping the button assignments is not supported. The second set of buttons is to accommodate left-handed users.*

The following table shows the actions available for the track ball and buttons, and the results of those actions.

Action	Result
Point (move pointer with the track ball)	Display Tool Tip when hovered over active object
Click (Left-click) 	When the pointer is over an active object, a click initiates various actions. Nothing happens when the pointer is clicked on a disabled object.

Action	Result
Double-click ✓ ✓	When the pointer is over an active object, a double-click initiates various actions. For example, edit an inspection.
Right-click ⓘ	Display a context-sensitive menu when you click on an enabled object. The context-sensitive menu often contains functions that are also available in a menu bar or other screens. For example, add a point to a polygon.
Drag (hold the left button while moving the track ball)	Examples: move a selected Region of Interest (ROI) around an image or move an inspection in a Tree View to change the order of execution.

## On Screen Keyboard (OSK)

Different types of on screen keyboards will be displayed depending on what kind of input is needed. When you want to type text or numbers into a field, right-click or double-click on a text input field to display the appropriate keyboard.

- If alphanumeric input is needed, a full alphanumeric keyboard will be displayed
- In numeric input only is needed, a smaller, numeric keypad only will be displayed

### *Alphanumeric keyboard*

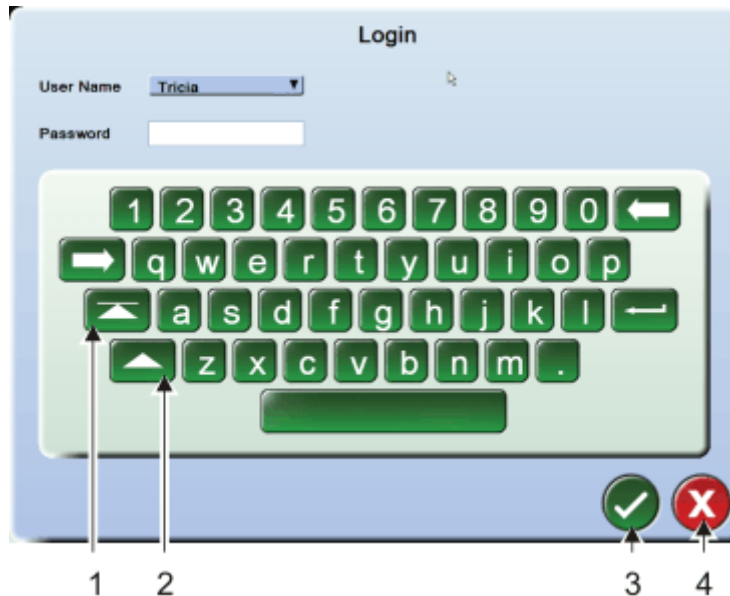



1	Shift lock button - capitalizes all letters until you press this button again.
2	Shift button - capitalizes one letter, then returns to uncapitalized letters automatically.
3	OK button - accepts the typed information and closes the keyboard screen.
4	Cancel button - disregards the typed information and closes the keyboard screen.

### *Numeric keyboard*

The numeric keypad is displayed when the input field requires a numeric entry. Most of the buttons are self-explanatory. Additional buttons are described below.

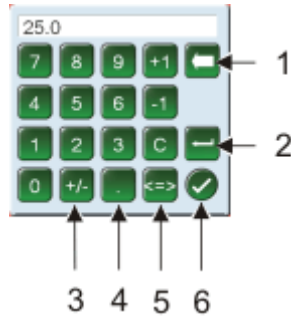
❖ Note: some buttons are not displayed if they are not appropriate for that field.

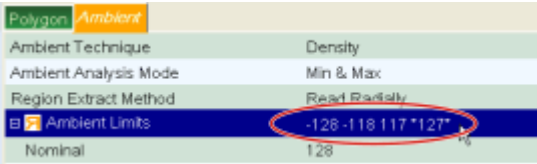

1	Backspace - removes a digit
2	Enter - populates the field in the Intellispec screen without closing the keyboard. This is useful if you want to test a value and see the results of the change immediately.
3	[+/-] makes the number positive or negative
4	[.] available only if a decimal number is valid in the input field
5	[<=>] cycles to the next limit of the parameter. If the parameter has more than two limits, then asterisks will surround the selected value in the menu.
	
6	 accepts your changes and closes the numeric keypad

## Mechanical keyboard (MKB)

The system supports the temporary connection of a conventional mechanical keyboard using one of the available **USB ports** (on page 35). This keyboard will mostly be used for system level tasks such as BIOS configuration, Network configuration, and Operating System level setup.



The keyboard:

- Is primarily used by Pressco Field Service Engineers
- Rests on the UPS when not in use
- Requires a stable location when in use

## USB Ports

There are USB ports available to back up or transfer data, and also to connect the optional mechanical keyboard. One is mounted on the side of the user interface.

Some touch screen monitors have additional USB connectors on the side of the monitor.

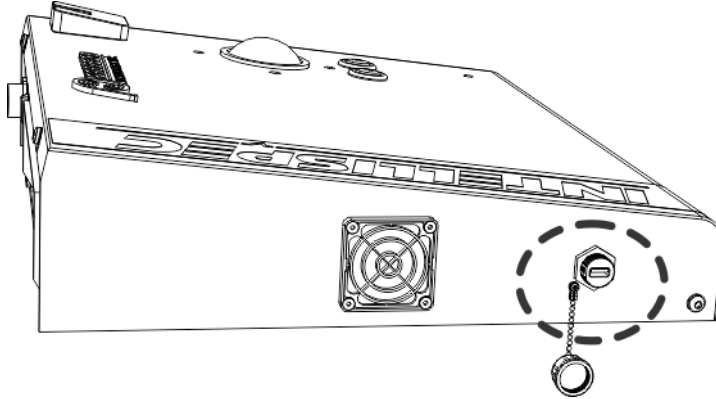

## Biometric login device

The **Biometric Identification login device** (see "**Adding a user with the biometric login device**" on page 50) is used to log in and out of the Intellispec system. This device is optional and must be purchased with the system.



To log in with this device, press your finger to the device. The following are conditions for use:

- You must use the same finger as initially set up by your administrator
- If you do not know how your account was set up (or which finger you used), contact your administrator
- If, after three tries, the Intellispec does not recognize your finger print, you must log in using the **on screen keyboard (OSK)** (see "**On Screen Keyboard (OSK)**" on page 34))

---

## User Interface Display - 4 Levels

The display on the user interface has four levels for viewing:





Look at the tab at the top of the screen to quickly determine which level you are viewing (from System Overview to Sensor Overview). The tab will read "System Overview" [level 1], "Lane n" [level 2], or "sensor name" [level 3]. In the Inspection Screen [level 4], the tab also reads "sensor name," but the inspection graphs and parameters are available to view and edit.

❖ Note: when you switch between System Overview and Lane Overview modes, you will see one screen 'minimize' to the task bar while your selected screen is displayed. This is normal.

➤ To view the four viewing levels:

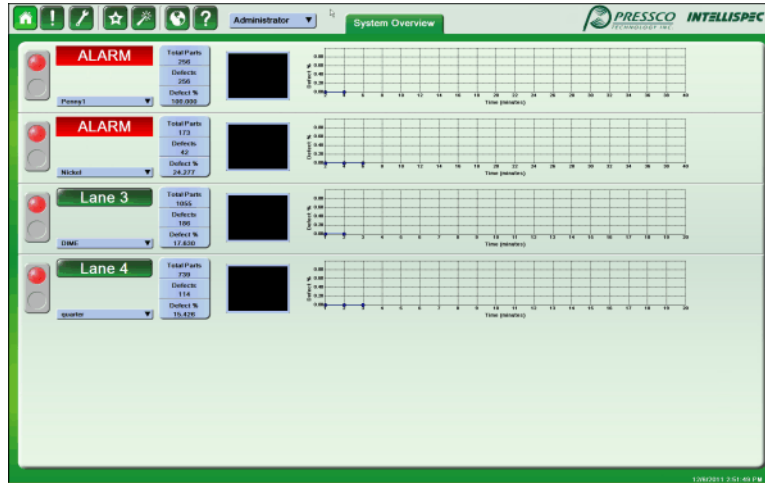
1. Click the Home button  to go to level 1, System Overview.
  - System Overview - Displays information that represents the complete system as well as a thumbnail line for each Lane that is configured. More information about the **System Overview screen** (on page 39).



2. Click a Lane button  to go to level 2, Lane Overview.
  - Lane Overview - Displays information for a particular Lane as well as a thumbnail line for each sensor used in that Lane. More information about the **Lane Overview Screen** (on page 40).



3. Click a Sensor button  to go to level 3, Sensor Overview.

- Sensor Overview - Displays information for a particular sensor, including an image area, sensor statistics, a graphics area that displays user-selectable graphs, and a user-selectable inspection list. More information about **Sensor Overview Screen** (on page 41).

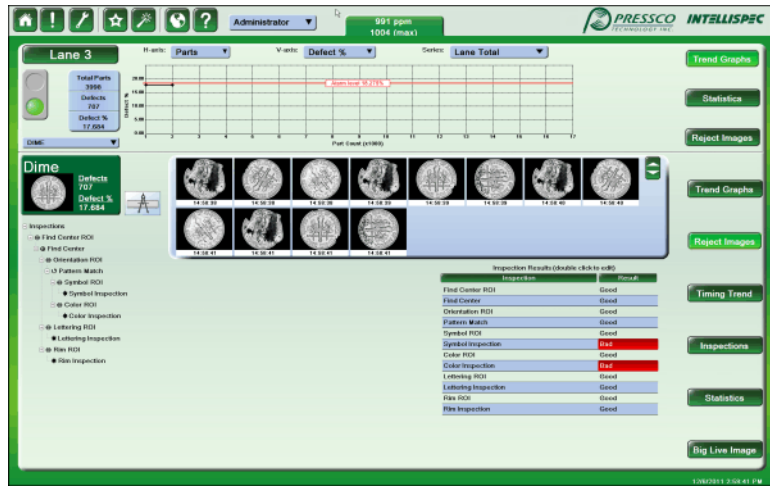

4. Double-click an inspection name in the Analysis Inspections list to get to level 4, Inspection Screen.

❖ *Note: Some menu items are only available to advanced level users.*

- Inspection Screen - Double-click on any inspection name to see this view, which allows you to see inspection parameters and make changes if necessary.

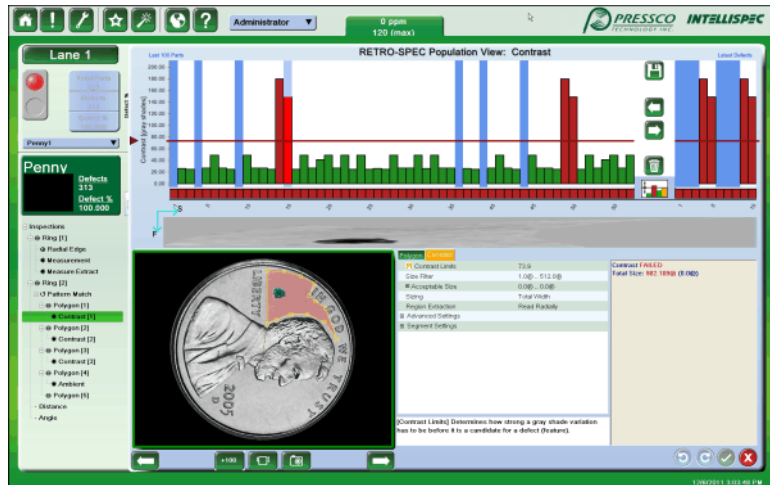

5. Click the exit button  to go back to level 3 Sensor Overview mode.

## System Overview screen

For a description of the toolbar icons, see *Menu Toolbar* (on page 42).

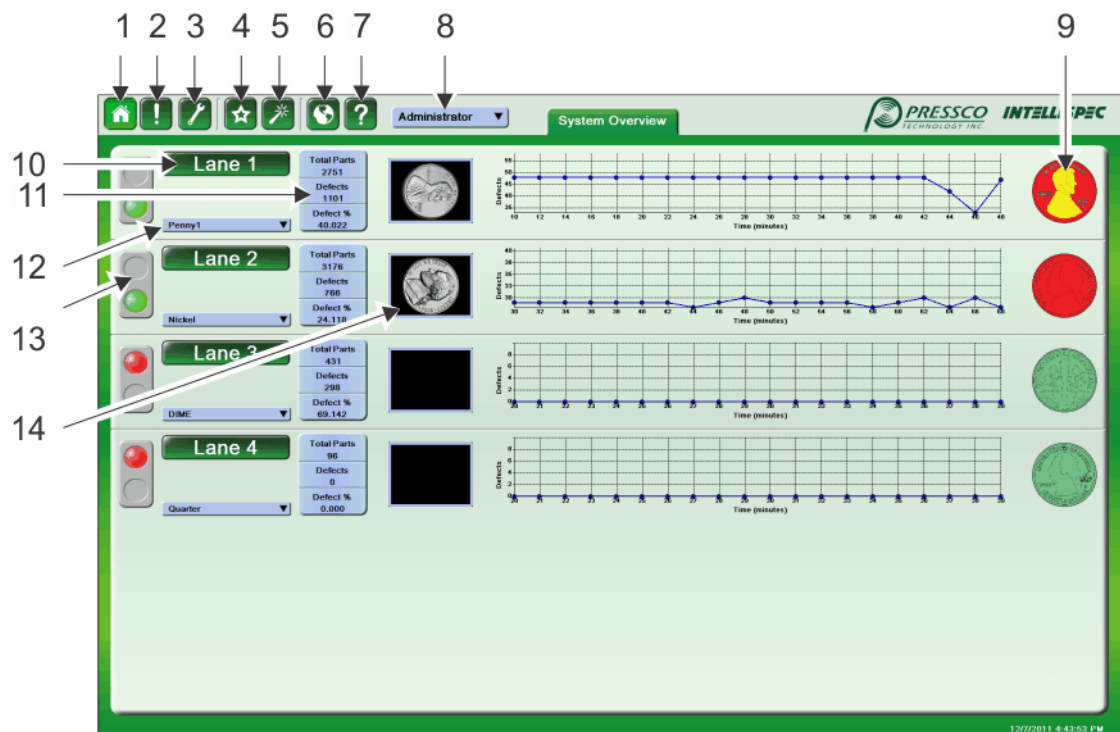

1	Home
2	Alarms
3	System Settings
4	Favorites
5	Wizards
6	Language
7	Help menu
8	Log in
9	Walk By Graphic
10	Click to go to Lane Overview
11	Lane Statistics
12	Current Part Program
13	Online/ Offline
14	Heartbeat Image

## Lane Overview Screen

1	Click the sensor button to toggle to detailed Sensor View and back
2	Switch to System Overview

### More Lane Information



Under the Lane Overview screen, click the More Lane Information bar to display additional graphs, statistics, or an additional Walk By graphic. Buttons on the right side of the screen provide different viewing options.

### Sensor Information

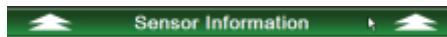

Under the Lane Overview screen, click the Sensor Information bar (at the bottom of the screen) to display the default sensor information. Graphs, images, or statistics are displayed depending which button on the right is selected.

### Statistics menu

Use the Statistics menu in the Lane Overview screen to view, reset, or print statistics.

❖ *Note: Some menu items are only available to advanced level users.*

#### ➤ To view the Statistics menu:

1. Go to the Lane Overview screen by clicking a Lane n button.

- Click over a statistics box. The Statistics menu is displayed. The items in the menu are described below.



**Clear Lane Statistics**

Clear the statistics for the lane only.

**Clear Lane Statistics and Clear Images**

Clear the statistics for the lane and empty the defective image buffer.

**Print Lane Report**

Send the lane statistics report to the default configured printer.

**Statistics Last Reset**

Display the date and time when the lane statistics were last reset.

**Sensor Overview Screen**

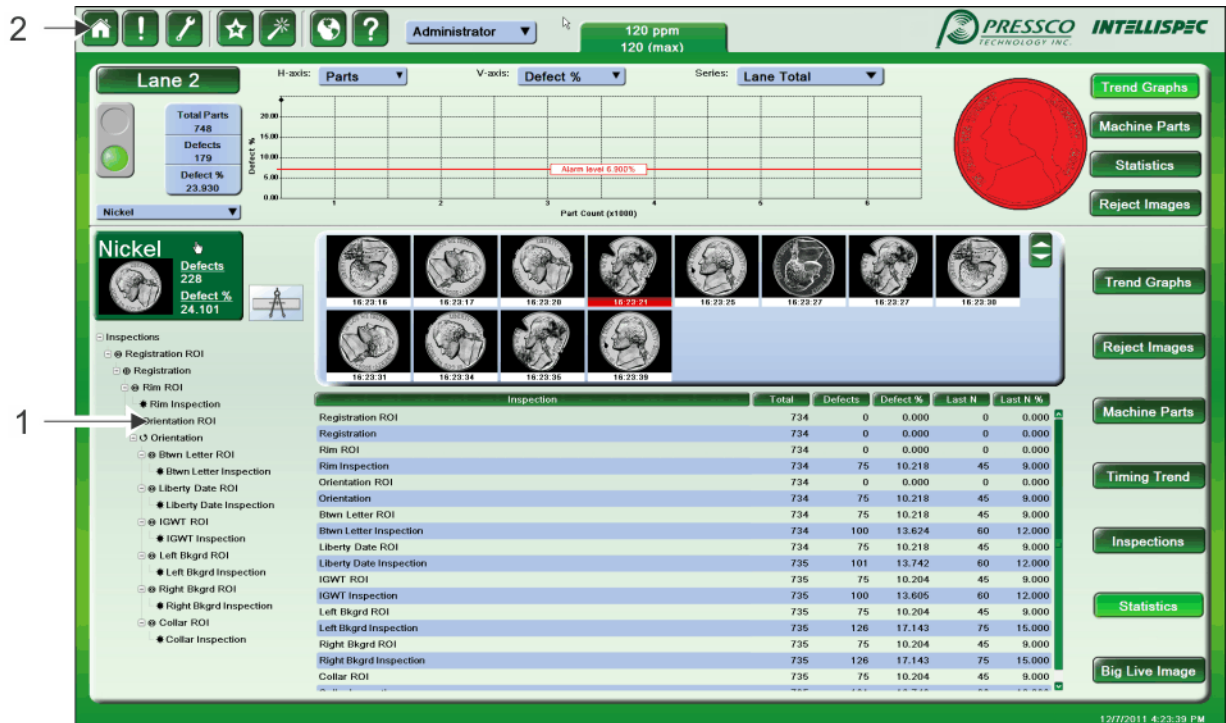

1	Double-click to open Inspection View
2	Switch to System Overview

## Inspection Overview Screen

2

Administrator 0 ppm 0 (max) PRESSCO INTELLISPEC TECHNOLOGY INC.

Lane 1

RETRO-SPEC Population View: Rim Inspection

Defects 389 Defect % 15.207

Camera 1 Defects 389 Defect % 15.207

Inspections

- Find Center ROI
- Find Center
- Orientation ROI
- U Pattern Match
- Symbol ROI
- Symbol Inspector
- Color ROI
- Color Inspection
- Lettering ROI
- Lettering Inspection
- Rim ROI
- Rim Inspection

Rim ROI

Contrast Limits	21.95	Rim Inspection PASSED
Size Filter	1.00 ( .203.00)	Total Size: 0.00 ( 5.00)
Acceptable Size	5.00	
Sizing	Total Width	
Region Extraction	Read Radially	
Advanced Settings		
Segment Settings		

[Contrast Limits] Determines how strong a gray shade variation has to be before it is a candidate for a defect (feature).

1

12/6/2011 5:22:53 PM

1	Close the Inspection View
2	The inspection window must be closed first to switch to System Overview

## Menu Toolbar



1	Home
2	Alarms
3	Tools
4	Favorites
5	Wizards
6	Language
7	Help

## Home

Click Home to return to the System Overview Screen. If a region or inspection editor menu is open, you must close it before anything else can be selected. The Home button is highlighted in the System Overview screen.

## Alarms

When this icon is selected, a different pop-up window appears depending on what screen you are on. For more information, refer to the section about **alarms** (on page 73).

## Tools

When this icon is selected, a different pop-up window appears depending on what screen you are on. For more information, refer to the section about **tools** (see "**Tools Menu**" on page 85).

## Favorites

From the Lane and Sensor Overview screens, select Take Screen Shot or Background Tasks. For more information, refer to the section about **favorites** (see "**Favorites Menu**" on page 130).

## Wizards

From the Lane or Sensor Overview screens, select wizards that assist in setting up certain features. At the present time the only wizard is for setting up the Walk By graphic. This allows you to select group names, inspections assigned to each group, and values that determine when areas of the Walk By graphic turn to yellow, red, or back to normal (green).

## Language

Select an available language from this menu.

## Help

Access the help documents, support package utility, remote support, launch Windows Explorer, and determine software version.

# Language



Click the language button to select a different language. Choose from the available options.

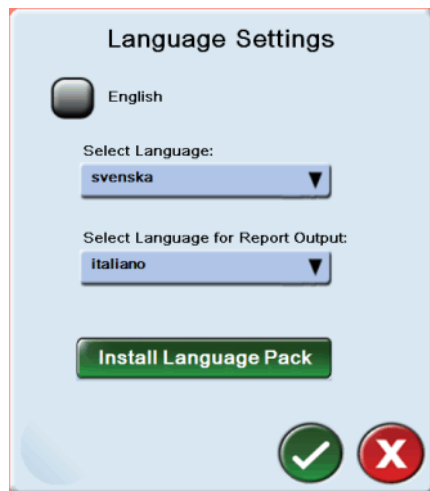

## English

If this box is checked, the names of the available languages are displayed in US English (example: *Swedish* instead of *svenska*).

## Select Language

Select the language to display on the user interface.

## Select Language for Report Output

Select the language for the reports, such as the Lane Report from the **Statistics menu** (on page 40).

### Install Language Pack button

When a new language is available, use this option to install the proper files. You will receive instructions from Pressco to install the language pack.

## Help

Click the Help icon  to:

- use the help files
- **create a support package** (see "**Creating a Support Package**" on page 124)
- access Pressco **remote support** (see "**Help - Remote Support**" on page 126)
- open Windows Explorer (administrators only)
- obtain your current software version

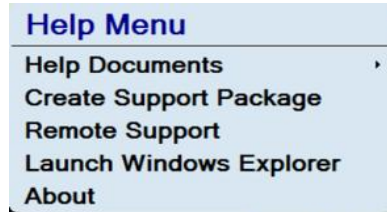

#### ➤ *To access the user manuals:*

1. Click the Help icon .
2. Select Help Documents, then select a manual from the list. The user manual is displayed.

---

## Online / Offline





- The stoplight is the online/offline indicator for each lane. A red light indicates the lane is offline; a green light indicates the lane is online.
- To switch from the online to offline mode, or vice versa, click the stoplight.
- Lanes can be put online or offline independently. If multiple lanes are configured, then one can be offline while another is online.

---

## Exiting the Intellispec software

You must have proper user permissions to exit the software. This prevents unauthorized system shutdowns. Contact your system administrator if you need user permissions.

#### ➤ *To exit Intellispec software:*

1. Log in.
2. Click the Home button .
3. Click the Tools button  to display the Tools menu.
4. Click the Exit System option.
5. A drop-down menu allows you to choose an option:
  - Shut down the Intellispec software only
  - Shut down the Intellispec software and computer

- Shut down the Intellispec software and restart the computer

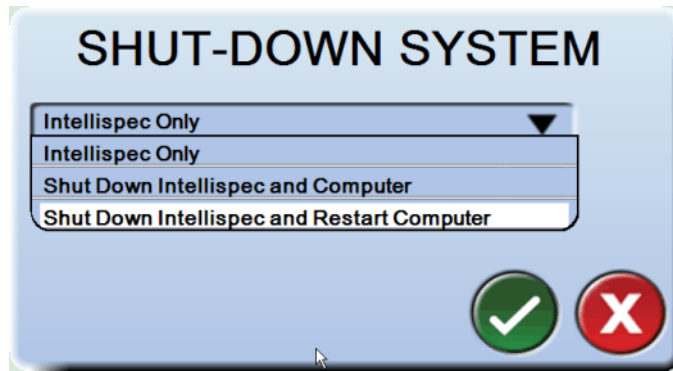

6. Choose the desired option from the menu and click the OK  button. The Intellispec software and/or computer shuts down (and restarts if applicable).



# Chapter 6

## User Accounts and Login Information

This section describes how to log in and how to manage user accounts.

### Logging in and logging out

Each user account has a list of permissions and restrictions. This is to give administrators more control over the system, and restrict others from performing tasks like changing lighting, or adding and editing inspections. When you log in, you can perform the tasks made available to you.

➤ **To log in, follow either of the steps below:**

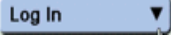
- Click the Log In button  to display the login dialog box. Select your user name from the drop-down list. Enter your password using the On Screen Keyboard by touch screen or trackball and buttons. The password characters will not be shown for security reasons.
- [With the optional **biometric sensor**] Press your finger to the sensor. The system will automatically determine your identity and log you in. If the system fails to recognize your identity after three attempts, the log in dialog box will appear, to allow you to log in with your user name and password.

➤ **To log out, follow either of the steps below:**

- Click the Log In button that displays your user name. The account drop-down menu appears. Select the Log Out button. The system logs you out.
- [With the optional **biometric sensor**] Press your finger to the sensor. The system logs you out.

❖ *Note: When another users logs in, the system automatically logs you out.*

### Log in menu

To ensure that only authorized users perform certain changes to the system, users are required to log in.\*

\*Some tasks can be configured so that users do not need to log in. This is done through Manage Permissions.

❖ *Note: Accounts may be shared by a group of people (example: Shift 1).*

➤ **To view the Log In menu:**

1. Click the Log In button  and enter your password. The text on the button changes to indicate who is logged in.
2. Click the Log In button again (which has your user name displayed on it). The Log In menu is displayed. Some options in this menu are only available to authorized users.

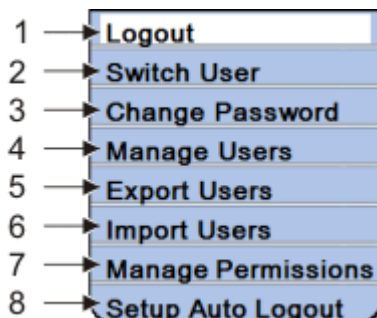

1	Logout - Logs out whoever is logged in
2	Switch user - Allows you to switch from one user to another
3	<b>Change Password</b> (see " <b>Changing your password</b> " on page 48)- Allows you to change only your password
4	<b>Manage Users</b> (see " <b>Managing user accounts</b> " on page 49) – Used to assign, remove, or edit users. This is where users are given access to specific tasks (example: one user is given the access to edit inspections and another is not given this access). You can also give users access to specific tasks through Manage Permissions.
5	<b>Export Users</b> (see " <b>Exporting user accounts</b> " on page 51) - Allows you to export user profiles from one Intellispec to another
6	<b>Import Users</b> (see " <b>Exporting user accounts</b> " on page 51) - Allows you to import user profiles from one Intellispec to another
7	Manage Permissions – This is where the system can be configured to allow pre-defined tasks to be performed with no log-in
8	<b>Setup Auto Logout</b> (see " <b>Setting up Auto Logout</b> " on page 57)– This feature will automatically log you out if there is no activity for a defined amount of time

❖ *Note: There is a Pressco Technician account for use only by Pressco Service Engineers. This gives access to unsupported features (menu items are a different color). If you log into this account and use those features, do so at your own risk.*

## Switching users

The Switch Users option from the Log In menu logs out the current user, and allows a new user to log in.

### ➤ **To switch users:**

1. Click the Log in button (which has the current user's name displayed).
2. Select Switch Users from the menu.
3. Select the new user name from the drop-down menu.
4. Enter the new user's password. The new user is logged in. The previous user is logged out.

### ➤ **If you have a biometric sensor:**

Press your finger to the biometric sensor device to log in. The previous user will be automatically logged out by the system.

## Changing your password

The Change Password function is available to all users.

❖ *Note: an Administrator can reset a password if necessary.*

### ➤ **To change your password:**

1. Log in.
2. Click the Log In button with your user name to see the Log In menu.
3. Select Change Password. The Change Password dialog box is displayed.
4. Enter your Old Password.
5. Enter a New Password.
6. Confirm your New Password.
7. Click the OK button  to accept the changes. The dialog box closes and your password is changed.

# Managing user accounts

The Manage Users button is only available to those with the Manage Users permission. This feature provides a wizard that allows you to Add a new user, Edit a current user or Remove any user. You may create one user account for a group of people and give that group the password to the account (example: Shift 1).

❖ *Note: the biometric login features are only used when the optional biometric login device is installed*

## ➤ To manage a user account:

1. Log in as an administrative user.
2. Click the button with your user name to see the login drop-down menu.
3. Select Manage Users. The Manage Users dialog box is displayed.
4. Select Add, Edit, or Remove a user. Follow the information on screen to complete these actions. The current step is highlighted on the left side of the configuration screen [item 1 in illustration below], and is repeated at the bottom of the screen.
5. Use the forward arrow button [item 2] to move to the next screen after you have entered the appropriate information. Use the back arrow button (not shown in first step) to return to the previous step. You do not need to enter information in each screen to move from one screen to the next.

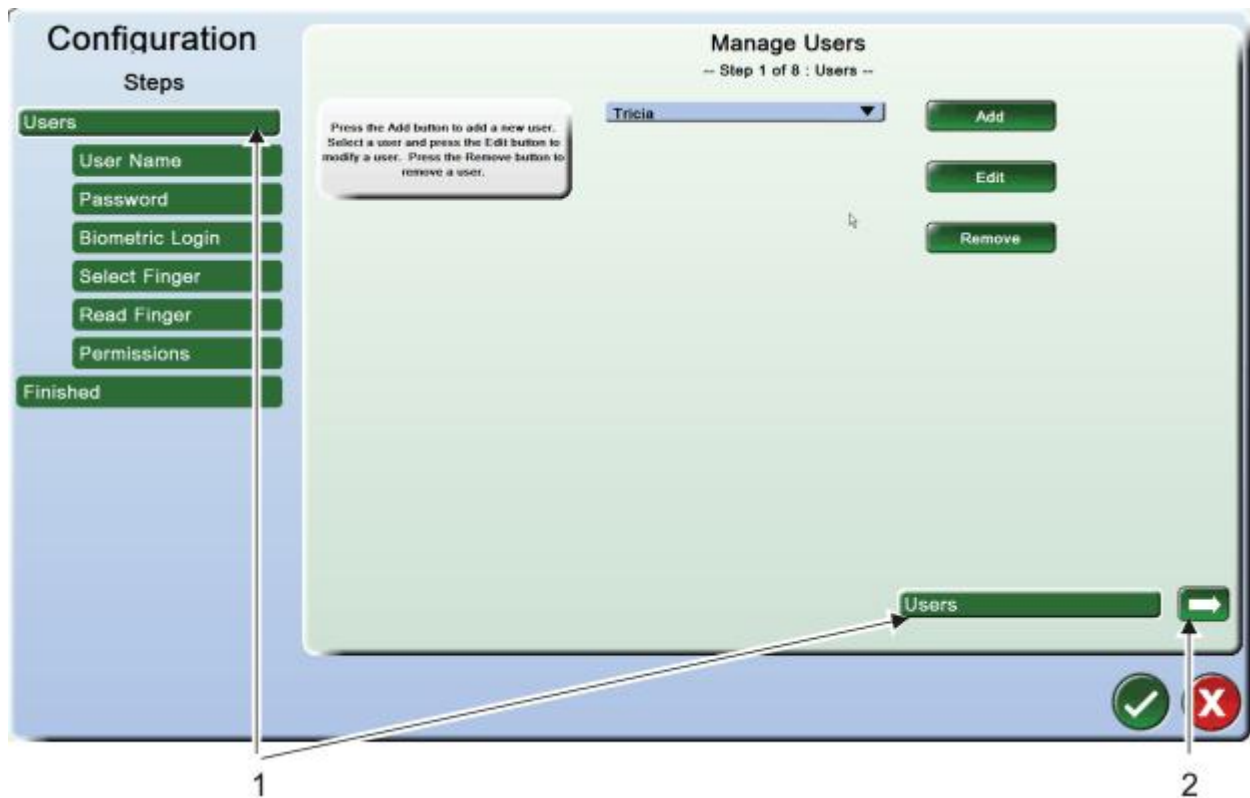

1	Current step in the wizard is highlighted.
2	Forward navigation to move to the next step. A back arrow (not shown) is available in later steps.

## Adding a user with the biometric login device

When you have the optional biometric login device installed, you will need the user present. The biometric login uses finger recognition software to log in rather than selecting a user name and entering a password. You can always **log in** (see "**Logging in and logging out**" on page 47) using your user name and password, even if you have a biometric login device. The maximum number of biometric accounts is 40.

- ❖ *Note: use of one account by a group of people is not supported with the biometric device. Each user must have his or her own account.*
- ❖ *Additionally, you cannot create two accounts for the same finger print. You could create two accounts for one person, but you must use two different fingers.*



### ➤ To add a user with the biometric login device:

1. Log in as an administrative user.
2. Click the button with your user name to see the login drop-down menu.
3. Select Manage Users. The Manage Users dialog box is displayed.
4. Click the Add button.
5. Add the user name when prompted. Click the forward arrow.
6. Enter a password, then Confirm it. Click the forward arrow.
7. [Biometric login] The next screen gives you the option of creating a biometric login or skipping over it. If you chose Skip, go to step 10. If you chose Create, go to step 8.
8. [Select Finger] Choose which finger the biometric sensor will read. Select any finger by using the touch screen or trackball and buttons to choose the circle above the finger. Only one finger can be used, and you must use this finger every time when logging in. Click the forward arrow.



9. [Read Finger] Click the Start Button at the top of the screen. The system will ask you to place the finger you selected on the biometric sensor. To ensure an accurate biometric measurement, you are asked for three readings. Instruct the user to place his or her finger on the biometric sensor three times when prompted. Click the forward arrow.
10. [Permissions] This is where you can set up what each user can and cannot do within the system. After you have selected the desired permissions, click the forward arrow. You can also change permissions later. For more information, see [Managing Permissions](#).
11. [Finished] Click the OK button  to accept changes and exit.

---

## Exporting user accounts

This allows you to export user accounts from one system to another. The user accounts may be used in other Intellispec Series V systems in your plant. You may also want to back up your user accounts in the event they are changed in the system.



➤ **What you need:**

- A USB memory device to export or import data
- User access permission to change permissions

➤ **To export a user account:**

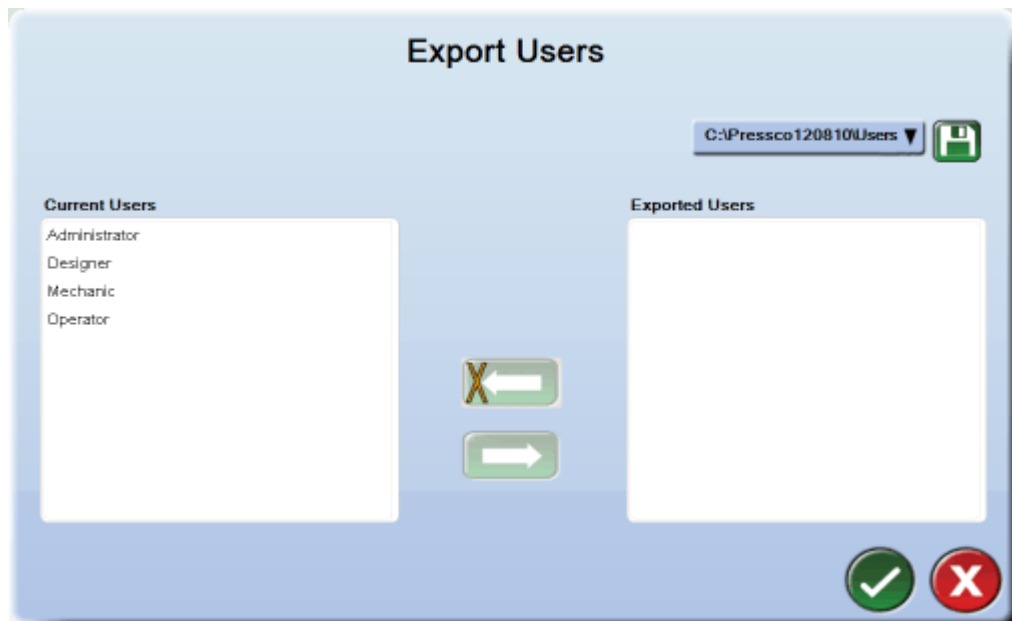
1. Log in as an administrative user.
2. Insert the **USB** (see "[USB Ports](#)" on page 35) device into an available slot on the Intellispec Series V system.
3. Click the button with your user name to see the login drop-down menu.
4. In the user login drop-down menu, click Export Users. The Export Users dialog box is displayed.



5. Select the user account that you want to export.
6. Click the right arrow  to export the user account.
7. Choose the destination to save the user account from the drop-down menu, or click the Save button  to browse to the USB device.
8. Click OK  to accept changes and exit the screen. The user account is exported.

# Importing user accounts

This allows you to import user accounts from one system to another. The user accounts may be used from other Intellispec Series V systems in your plant.



➤ **What you need:**

- A USB memory device with user accounts already saved on it, or a folder on the Intellispec hard drive with valid user accounts
- Administrative access to user accounts

➤ **To import a user account:**

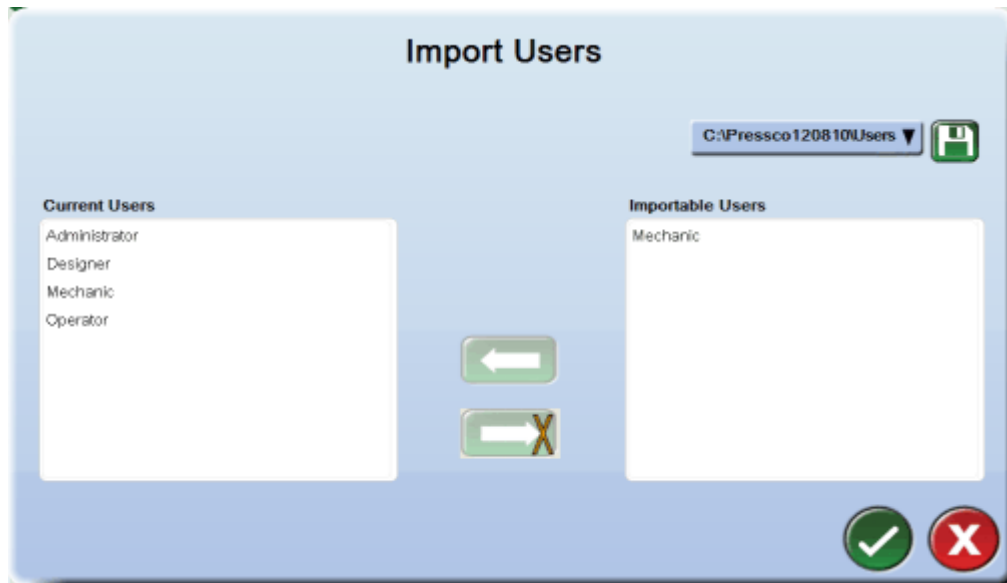
1. Log in as an administrative user.
2. Insert the **USB** (see "**USB Ports**" on page 35) device into an available slot on the Intellispec Series V system.
3. Click the button with your user name to see the login drop-down menu.
4. In the user login drop-down menu, click Import Users. The Import Users dialog box is displayed.



5. Select the user account that you want to Import from the right column. If you do not see any users available, click the Save button  to browse to a location where the user account is saved.
6. Click the left arrow  to import the user account.
7. Click OK  to accept changes and exit the screen. The user account is imported.

# Managing Permissions

The Intellispec has some default permissions that you can use to quickly set up users. To grant these permissions, click the appropriate button in the Manage Users screen. When you select these default permissions, you could also add or subtract specific permissions for the user.

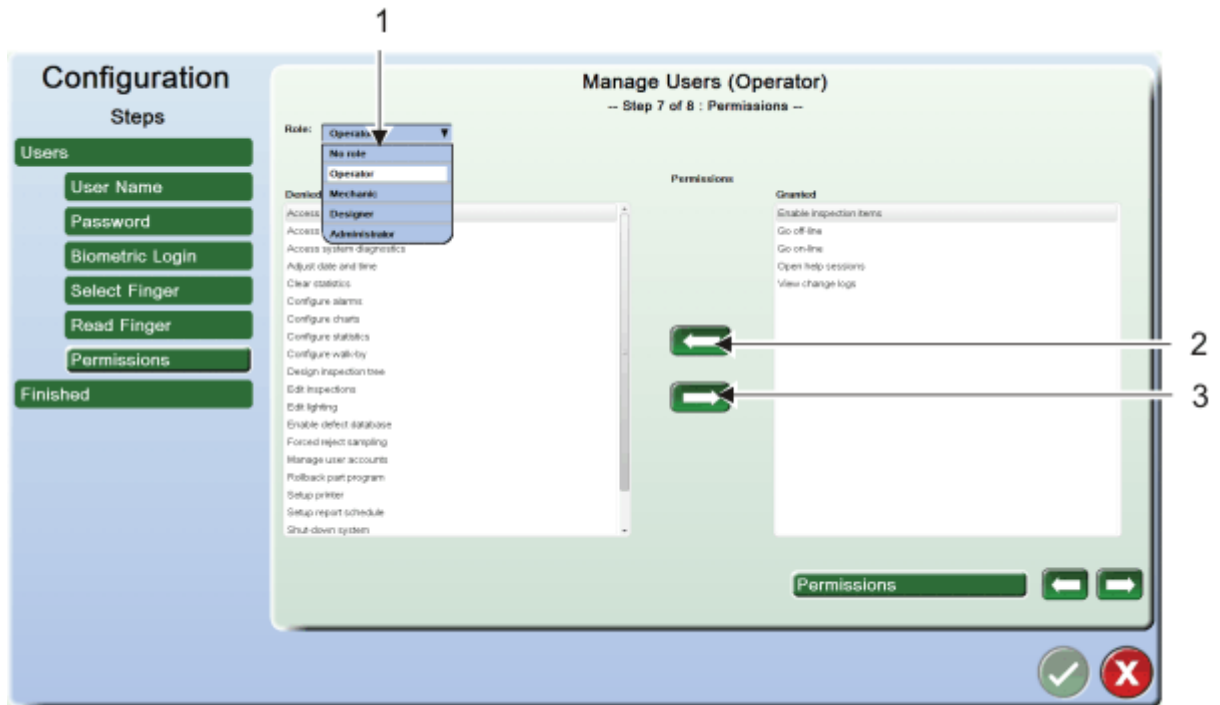

1	Choose from one of the predefined Roles to use the default permissions
2	Subtract one of the Granted Permissions. First highlight the permission in the list, then click the left arrow.
3	Grant one of the Denied Permissions to the selected user. First highlight the permission in the list, then click the right arrow.

Notes about roles and permissions:

- Granted permissions have priority over roles. If you change the permissions of a role, or change the role of a user, the granted permissions persist.
- When you change permissions for a role, all users with that role get the new permissions of that role. This is useful to change permissions for groups of users.

The following table provides a brief description of all the available default permissions. Note that some permissions may not be available in your list. For more information, refer to **Editing Permissions** (on page 56).

Key: ROLES: **O** = Operator; **M** = Mechanic; **D** = Designer; **A** = Administrator

	Permission	Description	O	M	D	A
1	Access advanced inspection parameters ( <b>Editor Options</b> (on page 183))	Access advanced parameters inside of the inspections, and access some inspection tree items (such as regions).			X	X
2	<b>Access image tools</b> (see " <b>Image Analysis</b> " on page 138)	Access the Image Analysis Tools.	X	X	X	X

	Permission	Description	O	M	D	A
3	Access system <b>configuration</b> (see " <b>Lane Setup</b> " on page 94)	Change system configuration values.		X	X	X
4	Access system diagnostics	Perform system functions including <b>I/O</b> (see " <b>I/O Diagnostics</b> " on page 108) and <b>correlation diagnostics</b> (on page 109).		X	X	X
5	<b>Adjust date and time</b> (see " <b>Adjusting Date and Time</b> " on page 123)	Adjust Intellispec system date and time.				X
6	Allow Task Manager Access	Access Windows Task Manager.		X	X	X
7	Cancel <b>Background Task</b> (see " <b>Background Tasks</b> " on page 131)	Cancel a background task if it is interfering with inspection.				X
8	<b>Clear statistics</b> (see " <b>Statistics menu</b> " on page 40)	Reset inspection statistics.	X	X	X	X
9	<b>Clear alarms</b> (see " <b>Viewing and Clearing Alarms</b> " on page 74)	Clear inspection and system alarms	X	X	X	X
10	<b>Configure alarms</b> (see " <b>Lane Alarm Configuration</b> " on page 76, " <b>Sensor Alarm Configuration</b> " on page 80)	Configure the lane and sensor alarms.		X	X	X
11	<b>Configure charts</b> (see " <b>Lane Setup</b> " on page 94)	Configure trend charts and other statistics charts.		X	X	X
12	<b>Configure statistics</b> (see " <b>Statistics Configuration</b> " on page 69)	Configure how the statistics graphs are displayed.		X	X	X
13	<b>Configure walk-by</b> (see " <b>Walk By Setup</b> " on page 60)	Name, set up alarms, and set up which inspections will be used with a particular region on a part. These regions are displayed in the walk-by graphic.		X	X	X
14	<b>Design inspection tree</b> (see " <b>Inspection menu</b> " on page 171)	Add or delete inspections.			X	X
15	Edit inspections	Edit existing inspections.		X	X	X
16	<b>Edit Lighting</b> (see " <b>Sensor menu</b> " on page 135)	Change the lighting settings for each camera.		X	X	X
17	<b>Edit Part Notes</b> (see " <b>Part Setup</b> " on page 91)	Add information to the part setup file.		X	X	X
18	<b>Enable defect database</b> (see " <b>Reporting</b> " on page 86)	Enable the optional defect database.			X	X
19	<b>Enable inspection items</b> (see " <b>Inspection menu</b> " on page 171)	Enable or disable individual inspections and the rejecter for those individual inspections.		X	X	X
20	<b>Forced Reject</b> (on page 105) Sampling	Request forced reject sampling.	X	X	X	X



	Permission	Description	O	M	D	A
21	Go <b>Offline</b> (see " <b>Online / Offline</b> " on page 44)	Put a lane offline.	X	X	X	X
22	Go <b>Online</b> (see " <b>Online / Offline</b> " on page 44)	Put a lane online.	X	X	X	X
23	<b>Install language pack</b> (see " <b>Language</b> " on page 43)	Update the language files for the user interface, if provided by Pressco.				X
24	Launch Windows Explorer	Launch Windows Explorer from Task Manager or from the desktop.				X
25	<b>Manage part programs</b> (see " <b>How to Create, Copy, or Import a Part Program</b> " on page 168)	Create, import, export, copy, or load part programs.		X	X	X
26	<b>Manage user accounts</b> (see " <b>Managing user accounts</b> " on page 49)	Open Manage Users which lets you add, edit and remove users.				X
27	<b>Open help sessions</b> (see " <b>Help - Remote Support</b> " on page 126)	Start a remote help session with Pressco Technical Support.	X	X	X	X
27	<b>Rollback part program</b> (see " <b>Part Program Change Log</b> " on page 174)	Roll the current part program back to a previous state.		X	X	X
29	Run Mass Manager	Used with mass sensors - select appropriate Scaling Recorder sessions to scale the Intellispec readings.		X	X	X
30	Run Mass Recorder	Used with mass sensors - enter sample data from cut and weighed bottles.	X	X	X	X
31	<b>Setup printer</b> (see " <b>Setting up a printer</b> " on page 124)	Set up a printer for Intellispec reports.				X
32	<b>Setup report schedule</b> (see " <b>Schedule Reports</b> " on page 88)	Schedule statistics reports to be generated periodically.		X	X	X
33	<b>Shut down system</b> (see " <b>Exiting the Intellispec software</b> " on page 44)	Shut down the Intellispec system.		X	X	X
34	Switch part program	Change the currently running part program. This also allows you to add a new part program.	X	X	X	X
35	<b>Switch report language</b> (see " <b>Language</b> " on page 43)	Choose a language for the Intellispec reports.				X
36	<b>View change logs</b> (see " <b>Part Program Change Log</b> " on page 174)	View the inspection change logs.		X	X	X
37	View system <b>logs</b> (see " <b>Log Reader</b> " on page 90)	View the system logs.	X	X	X	X

## Editing Permissions

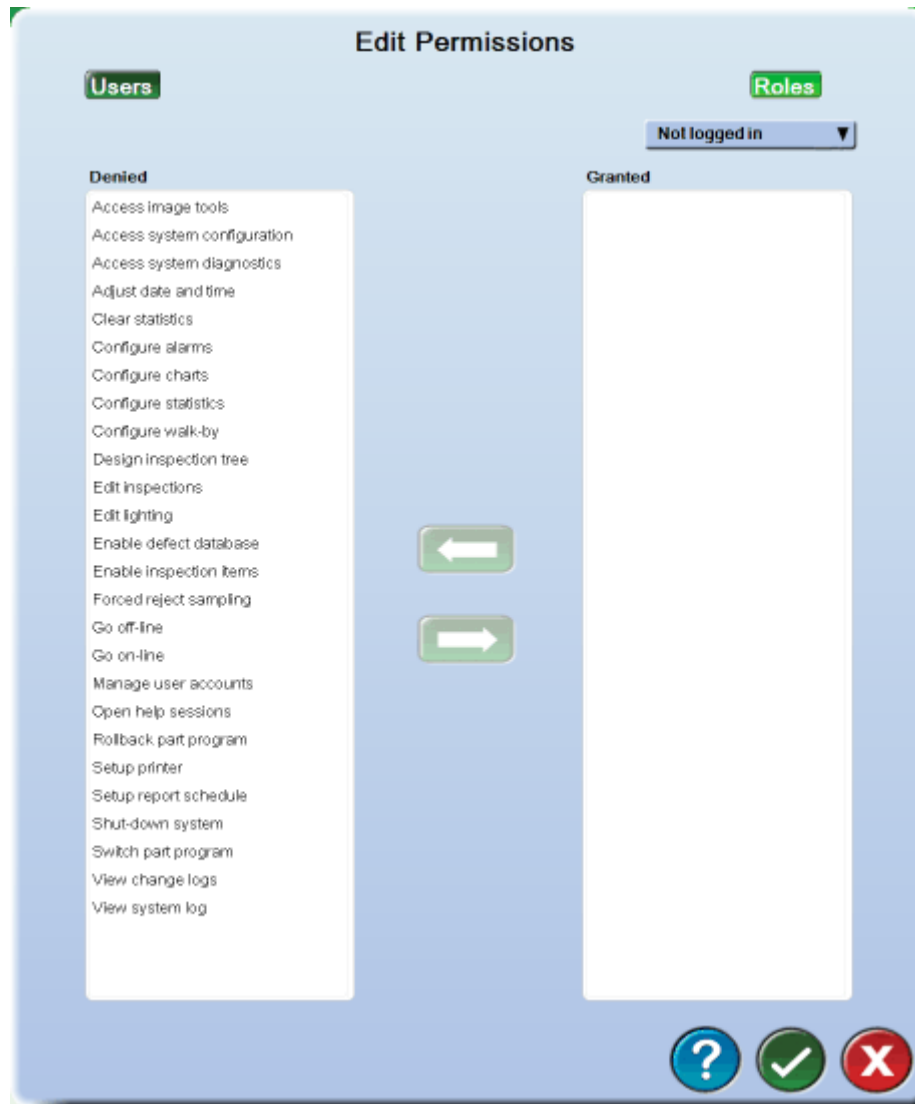
This feature allows you to set up permissions that will be available when no one is logged in. It also gives the selected permissions to all users. Once a permission has been selected, it will no longer appear in the available or selected columns when adding or editing a user in the Manage Users option. This feature is only available to Administrators (with Manage Users permissions).



### ➤ *To grant permissions to all users:*

1. Log in as Administrator.
2. Click the Log in button with your name on it to see the Log in menu.
3. Select Manage Permissions. The Edit Permissions screen is displayed.
4. Click the **Roles** button.
5. From the drop-down menu below Roles, select "Not Logged In."
6. Highlight the desired permission in the left column.
7. Click the right arrow  to move the permission to the right column.
8. Repeat the above two steps for all desired permissions.
9. Click the OK button  to accept changes and exit.



You can also remove permissions from all users that are assigned specific roles.



## Caution

Be sure you select the User name from the drop-down menu before you change Roles. Otherwise, you could change your Administrator permissions (example: from Administrator to Operator, and not be able to Manage User Permissions afterwards).

### ➤ *To remove permissions from a role:*

1. Log in as Administrator.
2. Click the Log in button with your name on it to see the Log in menu.
3. Select Manage Permissions. The Edit Permissions screen is displayed.
4. Click the **Roles** button.
5. From the drop-down menu below Roles, select the role from which you want to remove the permissions.
6. Highlight the desired permission in the right column.
7. Click the left arrow  to move the permission to the left column.
8. Repeat the above two steps for all desired permissions.
9. Click the OK button  to accept changes and exit.

You can also manage permissions for any user.

### ➤ *To edit a user's permissions:*

1. Log in as Administrator.
2. Click the Log in button with your name on it to see the Log in menu.
3. Select Manage Permissions. The Edit Permissions screen is displayed.
4. Select a user from the User drop-down menu.
  - Move the desired permissions between Denied and Granted. Or:
  - Assign that user a new role. For example, change Jane's permissions from Operator to Mechanic. The user will acquire all permissions for that role, including any that you have assigned separately from Pressco's default settings.
5. Repeat the above step for all desired permissions.
6. Click the OK button  to accept changes and exit.

---

## Setting up Auto Logout

This feature will automatically out any user after a set number of minutes of inactivity.

### ➤ *To set up Auto Logout:*

1. Log in as an administrative user.
2. Click the button with your user name to see the login drop-down menu.
3. Select Setup Auto Logout. The setup menu is displayed.
4. Click the box next to "Auto Logout" to enable the feature. A check mark is displayed in the box when it is enabled.
5. Set the Wait time in minutes by clicking the up or down arrows, or by highlighting the number of minutes and typing a new value (from 1 to 9999 minutes).

6. Click the OK button . All users will be logged out automatically after the set number of minutes of inactivity.

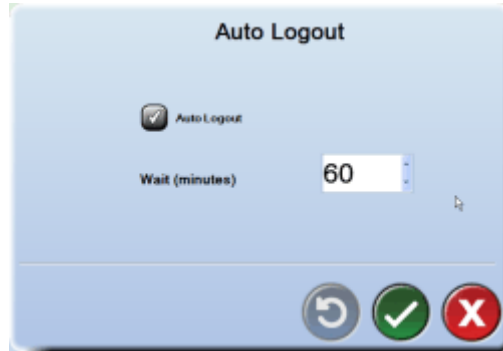

# Chapter 7

## Graphs and Image Displays

Several graphs are available on the user interface to help you view inspection trends. This section discusses the buttons on the right side of the screen in the Lane Overview and Sensor Overview modes.

### Walk By Graphic

Walk-by

This feature uses a graphic representation of a part so that you can quickly identify which area of the part is failing. It is called Walk By because you can quickly walk by the Intellispec and look at the graphic to determine the status of inspection:



- **Green** areas indicate that parts are passing inspection.
- **Yellow** warning areas notify you that the spoilage rate is approaching, but has not yet reached a critical level. This allows you to make necessary changes to the manufacturing process before the failure rate gets too high.
- **Red** areas indicate the spoilage rate has exceeded user defined limits.

The defect percentage rate at which each group reaches warning or failure limits is defined in **Walk By Setup** (on page 60).

There are two available Walk By Graphics:

- A small Walk By Graphic is displayed in System Overview, Lane Overview, and Sensor Overview modes
- A large Walk By Graphic can be displayed in Lane Overview mode

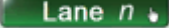
#### ➤ To see the large Walk By Graphic:

1. Click a Lane n button to view the Lane Overview mode. 
2. Click the More Lane Information bar in the center of the screen to display more graph options. 
3. Click the Walk By button on the right side of the screen.  The Walk By Graphic is displayed in the center of the screen.

The large Walk By Graphic displays the group names, pointing to the appropriate areas on the part. It also displays the current defect percentage for each of those groups, from inspection results.

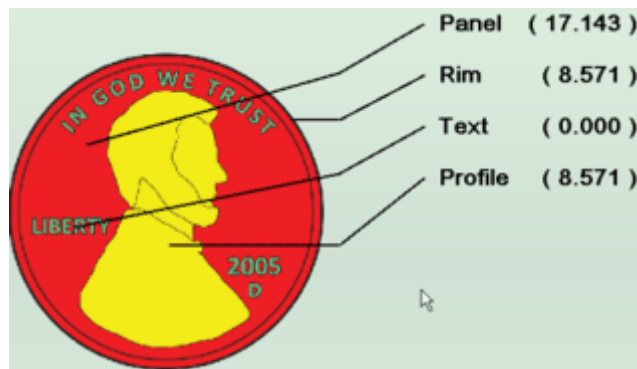

## Using the Walk By Graphic

You can view inspection information by clicking on the areas of the graphic. The Intellispec will display the configured inspection group and detail. The example below shows:

- The Panel group was clicked - all the inspections for Panel are displayed in the table
- The Panel area in the Walk By Graphic is red - The average defect % for the group of inspections exceeds the failure limit from the **Walk By setup** (on page 60)

The screenshot shows the 'Lane 1' interface. On the left, there are statistics for 'Total Parts' (312998), 'Defects' (62599), and 'Defect %' (20.000). Below these is a 'Penny1' dropdown. The main area features a table with columns: Inspection, Total, Defects, Defect %, Last N, and Last N %. The table lists several inspections for 'Polygon' and 'Contrast'. A red circle highlights the 'Detail: Panel' dropdown menu. To the right is a red circular graphic of a penny with a yellow profile of George Washington.

Inspection	Total	Defects	Defect %	Last N	Last N %
Polygon	312615	26794	8.571	78	7.800
Contrast	312615	44658	14.285	130	13.000
Polygon	312615	26794	8.571	78	7.800
Contrast	312616	35727	11.428	105	10.500
Polygon	312616	26795	8.571	79	7.900
Contrast	312616	44659	14.286	131	13.100

Double-click an inspection from the table (example: a Contrast inspection) to open and edit that inspection. Note: Some menu items are only available to advanced level users.

## Walk By Setup

This screen allows you to set up the Walk By Image. Each Lane can be set up differently if needed.

Each area of the part graphic display is:

- Assigned a group name.
- Assigned the correct inspections for that group.
- Configured to turn the area yellow or red when defined defect statistics are achieved.

❖ *Note: you must have correct user permissions to set up the Walk By Graphic. You must also have a part program loaded.*

### ➤ To get to this screen:

From the Lane or Sensor Overview screen, click the Tools button  to see the Tools menu > Lane set up > Walk By Setup.

The screenshot shows the 'Walk By Groups' setup screen. At the top, it says 'Walk By Groups' and 'Step 2 of 5 : Group Name'. On the left is a circular graphic of a dime with the text 'UNITED STATES OF AMERICA' and 'ONE DIME'. In the center, there is a text input field labeled 'Outer Edge' and a button that says 'Enter or edit the group name.'. Below this is a large virtual keyboard with green keys. At the bottom right, there is a 'Group Name' label and two arrow buttons.

➤ **To set up the Walk By graphic:**

1. Follow the instructions on screen, and navigate using the buttons at the bottom of the screen. Some parameters are explained below.
2. After the last screen, the system takes you back to the first screen so that you can set up another group. If you are finished, click the OK button  at the bottom of the screen to accept your changes and exit the screen.

**Group**

Each graphical area on the part is assigned to a group - this is defined in the graphic file. Assign as many inspections as you wish to a group, preferably those inspecting that area of the part. Inspections can be from any sensor within the same part program on the lane. Some drop-down menus on the user interface refer to 'groups' - these represent groups of inspections that inspect one area of a part.

A group can be a contiguous area, or a group of related areas on a part, as shown in red below.



**Warning Percent**

Set the value at which the group on the Walk By Graphic turns yellow. **Yellow** warning areas notify you that the spoilage rate is approaching, but has not yet reached a critical level. This allows you to make necessary changes to the manufacturing process before the failure rate gets too high.

❖ *Note: this warning percentage is not connected to inspection warning limits. Those limits are set separately. Additionally, this warning percentage does not affect the Excessive Warnings alarm.*

**Failure Percent**

Set the value at which the group on the Walk By Graphic turns red. **Red** areas indicate the spoilage rate has exceeded user defined limits.

❖ *Note: this failure percentage is not connected to inspection limits. Those limits are set separately. Additionally, this failure percentage does not affect the rejects alarms.*

**Group Digital Outputs (for Extended I/O option)**

Select the group number (Group 0 through 15) to trigger an output signal through the **Extended I/O board** (on page 337). If your system has firmware version lower than F168, then you will have outputs 0 through 14 available.

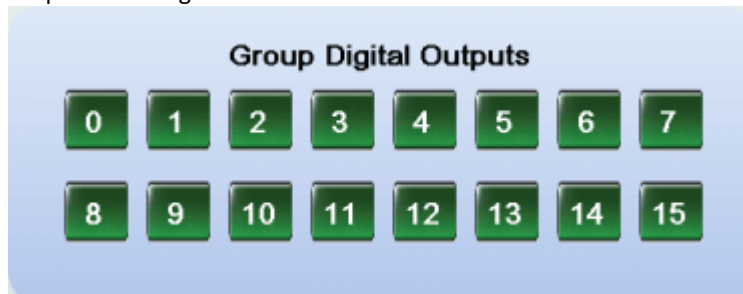

The outputs go active when any inspection within the assigned group fails. You can use these outputs to monitor the process within your plant and make adjustments as necessary.

You can assign multiple groups to one output. The groups can contain inspections from any sensor within their corresponding lane part program. Each lane may have its own Extended I/O board, so you cannot combine inspections from different lanes.

# Trend Graphs

## Trend Graphs

➤ **To view the Lane trend graphs:**

1. Select a lane (click a Lane n button).
2. Click the Trend Graphs button on the right side of the screen. The trend graph is displayed.

Trend graphs are available to view statistics based on specified criteria. These graphs are available for each lane and each sensor within that lane. You can select criteria for the H-axis, the V-axis, and Series. There is an adjustable Alarm Level for Defect %. Both the H-axis and V-axis adjust automatically to higher and lower values. The Alarm Level will adjust as well. Below is a list of possible combinations for Time and Parts based graphs.

H-axis	V-axis	Series
Time	Defect %	Lane Total
	Defect Count	All Walk-By Groups
	Defect Cost	All Sensors
	Parts and Defects	Individual Sensors
Parts	Defect %	Lane Total
	Defect Count	All Walk-By Groups
	Defect Cost	All Sensors
		Individual Sensors

For Trend Graphs, you can select which data to display. Select from the Series drop-down menu.

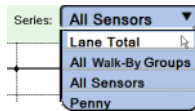

### Lane Total

Displays the statistics averaged for all sensors within the lane.

### All Walk-By Groups

Displays the statistics for inspection groups. These groups are defined in the Walk By Graphic setup, and pertain to a specific area of a part.

### All Sensors

Displays the statistics for each sensor.

### Individual Sensors [names vary]

Displays the statistics for only the selected sensor.

Note: A key (to explain color-coding and data point shape) is displayed to the right of the graph for All Walk-By Groups and All Sensors.

➤ **To change the graph criteria:**

1. Click any button (next to H-axis, V-axis, or Series) to view the drop-down menu options.
2. Select the desired criteria. The graph is updated to display based on your chosen criteria.

When the data falls outside of the current viewing range (example, time) a scroll button  becomes available next to the Series drop-down box.

➤ **To view other data:**

1. Click the scroll button . A scroll bar becomes available.

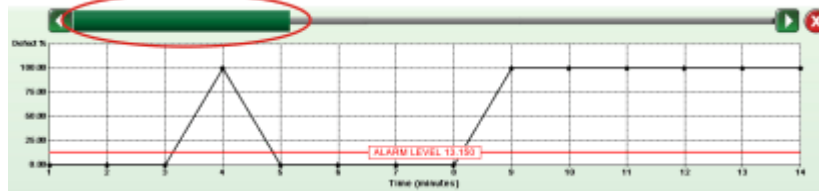

2. Click and drag the scroll bar to view the desired data.
3. To exit, click the exit button . The graph returns to the current data.

## Multiple Trend Graphs

In the **Sensor Overview screen** (on page 41), the upper and lower portions of the screen can display different trend graphs. For example, you could display a time based graph at the top of the screen, and a part based graph at the bottom of the screen. When the Trend Graph button is available on the right side of the screen in multiple locations, you could view any combination of trend graphs as you wish.

## Trend Chart Configuration - System Overview

This is the setting for the trend chart displayed on System Overview screen.

❖ *Note: the vertical axis setting is automatically scaled to best represent the data on the chart.*

➤ **To change the chart configuration:**

1. Click the Home button  to view the System Overview screen.
2. Right-click over the trend chart. The Chart Configuration menu is displayed.

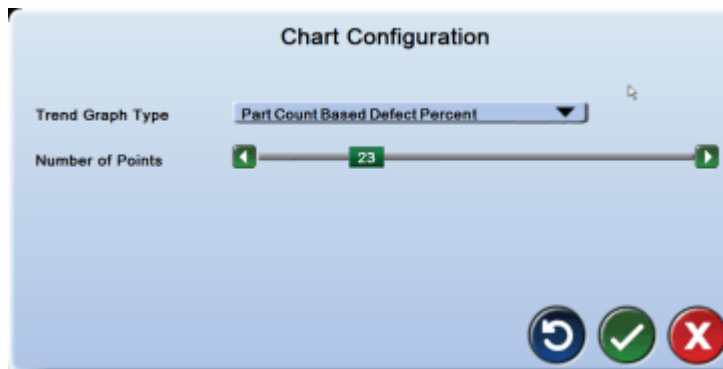

3. Choose from the available trend chart types, and select the number of points to display on the chart.
4. Click the OK button  to accept changes and exit the menu. The selected chart is displayed in the System Overview screen.

❖ *Note: these changes affect all trend charts in the System Overview screen*

## Trend Chart Configuration - Lane Overview

These settings affect the display of all the trend charts in the Lane Overview or Sensor Overview screens.

❖ *Note: the statistics for the lane are reset when you change a configuration setting.*

### ➤ To change the trend chart display:

1. View the Lane Overview or Sensor Overview screen by clicking either a Lane n button or a Sensor n button.
2. Click one or all of the Trend Charts buttons on the right side of the screen to display a trend chart.
3. Right-click over one of the trend charts. The Graph Menu is displayed.
4. From the Graph menu, select Configuration. The Trend Chart Configuration menu is displayed.

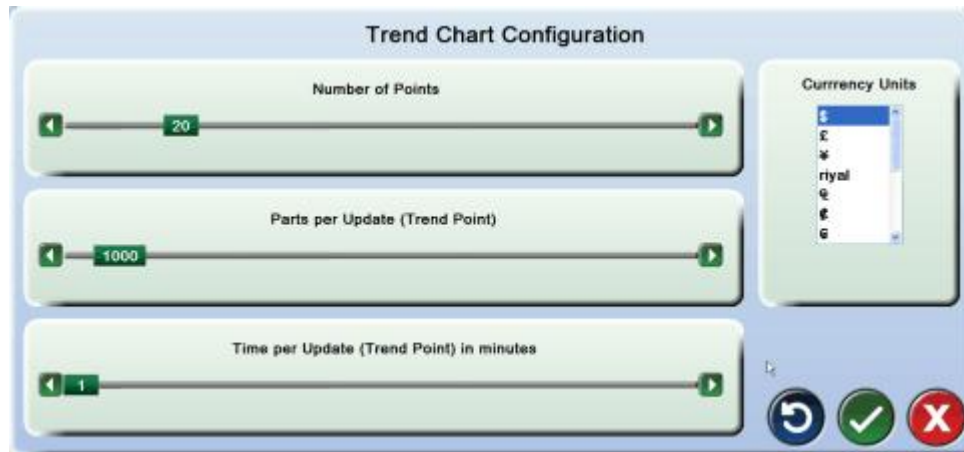

5. Select the desired settings from all the available parameters.
6. Click the OK button to save your changes and exit the screen. All the trend charts for the selected lane are updated to reflect your changes.

## Alarm Percentages in Trend Charts

The alarm level can be adjusted when Defect % is selected for the V-axis. Click and drag on the red Alarm Level line to adjust it. This also changes the alarm percentage in the **Lane Alarm Configuration** (on page 76) menu. The illustration below shows Sensor Overview mode with Trend Charts displayed for both Lane and Sensor. Changing the alarm percentage in any one of the Trend Charts or Lane Configuration menu changes the percentage in all the other locations.

❖ Note: Changing this alarm percentage does not affect the alarm percentage level in the Walk By Graphic.

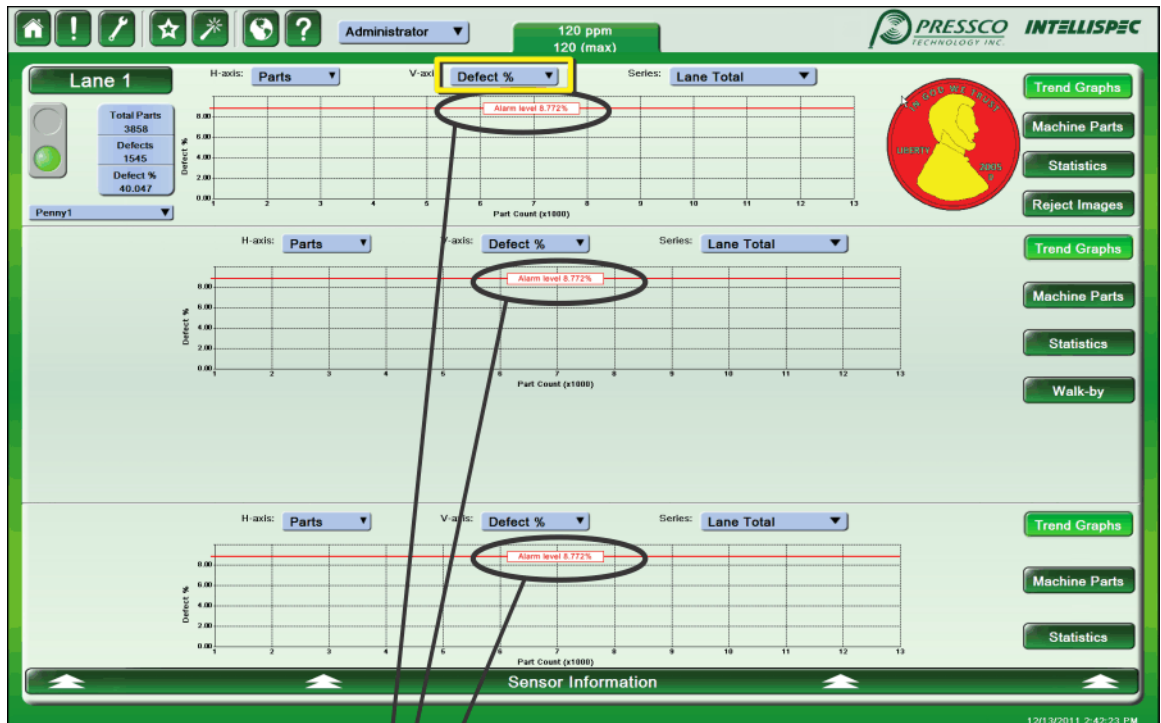

## Reject Images



Reject Images are images from the last 100 defects from a sensor (or all sensors for Lane Overview mode). These images are available in the Lane Overview screen and the Sensor Overview screen.

➤ **To view Reject Images:**

1. From the System Overview screen, click a Lane n button to display lane information.
2. Click a Reject Images button on the right side of the screen. Note: there are buttons for Lane and Sensor levels - these display images for the entire lane or just the sensor.

- **Lane Reject Images** show a variety of images from different Sensors. Below the image is the name of the Sensor it came from and what time it was rejected. You can scroll through the images using the arrows. Clicking on an image will bring you to the Sensor from which it failed.

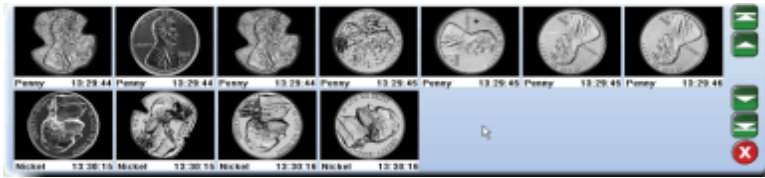

- **Sensor Reject Images** show snapshots of failed images from that Sensor only. Below the snapshot is the time it was rejected.

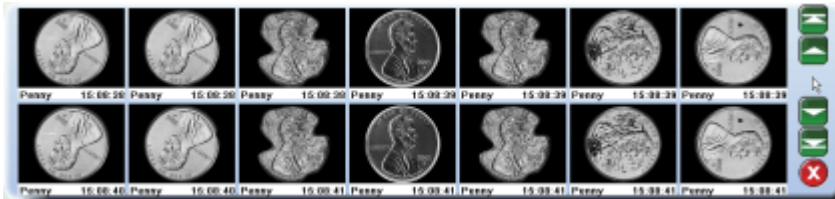

➤ **To use the images:**

- Click an image from the Lane Reject images to display the corresponding Sensor information in the lower part of the screen.

Inspection	Result
Ring	Good
Radial Edge	Good
Measurement	Good
Ring [2]	Good
Pattern Match	Bad
Polygon	Bad
Contrast	Bad
Polygon	Bad
Contrast	Good
Polygon	Bad
Contrast	Bad
Polygon	Bad
Ambient	Good

- Click any one of the small images to display a larger version of that image.
- Click on the large image to display a magnified portion of the image. This is useful to see small defects. Click and drag on the magnified portion to navigate around the image. Click in the magnified area to toggle the magnifier.



- Right-click on the image to choose a zoom amount. An enlarged image, the same size as the **Big Live Image** (on page 72) is displayed. Use the navigation arrows, or click and drag the cursor to pan around the image.
- From the pop-up menu, you may also choose **Image Analysis** (on page 138) (when the lane is offline).
- Click the exit button  to close the zoom window

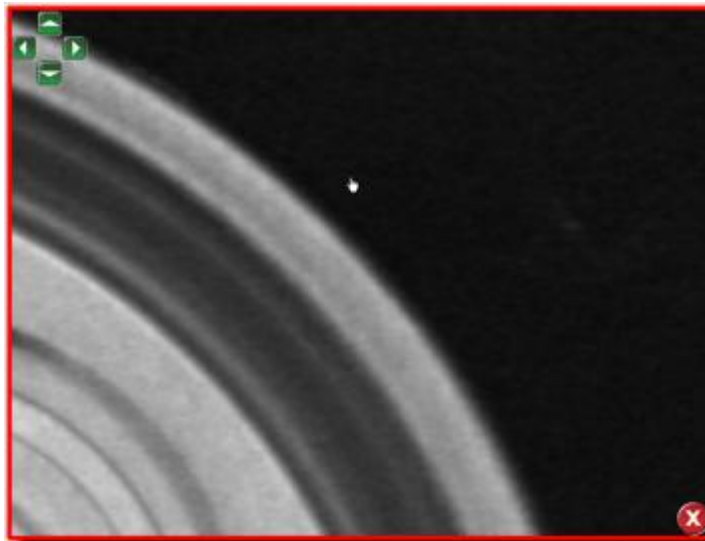
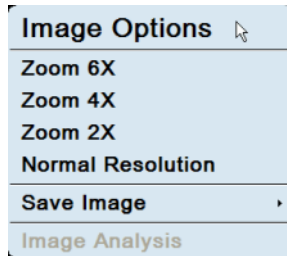

## Machine Part Graphs

Machine Part Graphs are available when you have the Correlation option installed. Machine Parts Graphs display defect information for each machine part. Below is a list of possible combinations for Defect % and Defect Count.

H-axis	V-axis	Series
Defect %	Machine Parts	Lane Total All Sensors
Defect Count	Machine Parts	Lane Total All Sensors

An example graph is displayed below. It shows defects for a machine part type, and the number of defects correlated to each sensor.

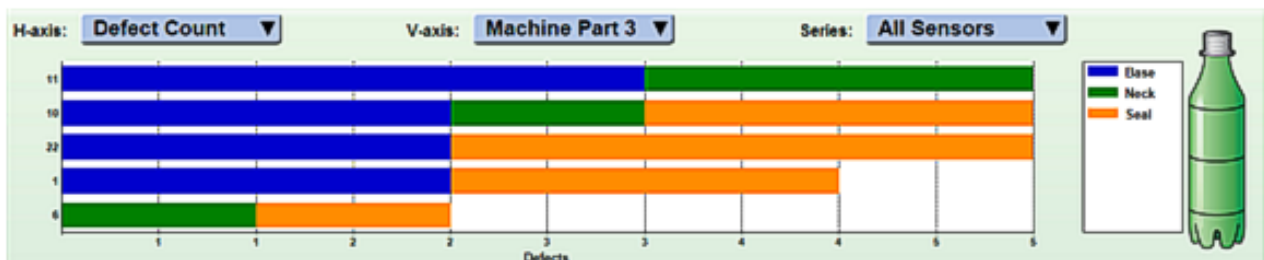

# Timing Trend

## Timing Trend

❖ *Note: this chart is mostly used by Pressco service engineers during installation, or it can be used when additional inspections or hardware have been added to the system.*

This chart displays the time required to run inspections. It is important to view the inspection timing, especially if you have multiple sensors or multiple lanes, to make sure that the system is inspecting all parts before they reach the reject station.

The choices for the Series in the Timing Trend chart allow you to choose Sensor Total, which is all inspections for that sensor, or any individual inspection for that sensor.

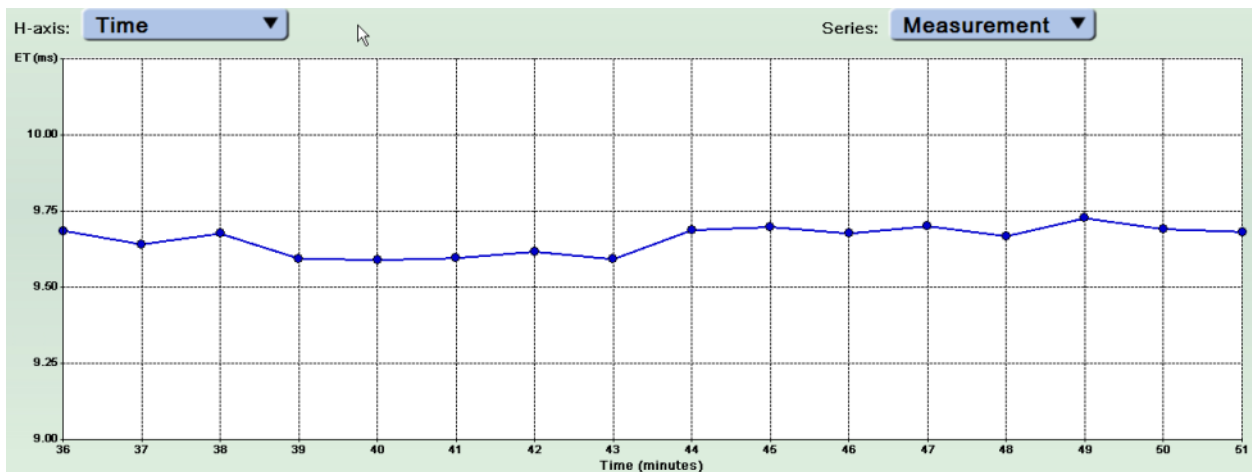

# Inspections graph

## Inspections

Click the Inspections button on the right side of the screen to see the Inspections Graph. This graph displays the Defect Count or Defect % for the selected sensor. It displays the failed inspections in descending order of failure. The example below is the graph shown in both Lane Overview and Sensor Overview modes.

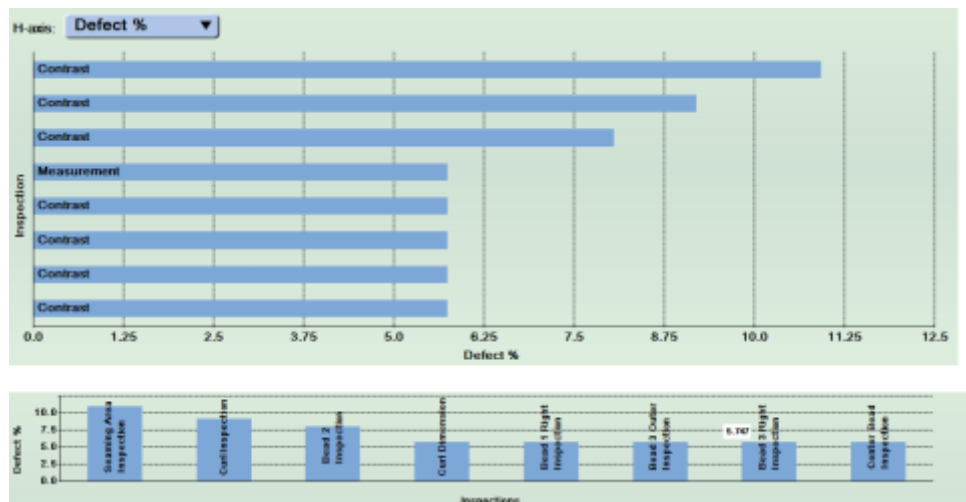

# Statistics Grid



The Statistics Grid displays information about each Sensor. There are two different types of Statistics Grids: Lane and Sensor.

## Lane Statistics Grid

The Lane Statistics Grid (in Lane Overview mode) displays general information about each Sensor. It shows the Total number of parts run, Sensor, Defects, Defect %, Last N, and Last N %.

Show: <b>Sensors</b>	Detail: <b>All</b>	Sensor	Total	Defects	Defect %	Last N	Last N %
		Rivet	56748	56748	100.000	953	95.300
		Panel	56748	56748	100.000	953	95.300

## Sensor Statistics Grid

This grid is available when you display Sensor information. It shows specific information for each sensor, including Inspection, Total number of parts run, Defects, Defect %, Last N, and Last N %.

Inspection	Total	Defects	Defect %	Last N	Last N %
Pattern Match	56748	56748	100.000	953	95.300
Radial Edge	56748	0	0.000	0	0.000
Ring	56748	0	0.000	0	0.000
Ring	56748	0	0.000	0	0.000

❖ *Note: you can **configure** (see "Statistics Grid options" on page 71) the statistics display. Your system may not display all of the above-mentioned items.*

To display the statistics grid, click the Statistics button on the right side of the screen. There may be multiple buttons, depending which screen you are viewing.

## Sorting order

To sort any column in ascending or descending order, click the button at the top of the column. Click it again to toggle to the opposite order. Right-click to clear sorting in the statistics grid.

Inspection	Total	Defects	Defect %	Last N	Last N %
Pattern Match	56748	56748	100.000	953	95.300
Radial Edge	56748	0	0.000	0	0.000
Ring	56748	0	0.000	0	0.000
Ring	56748	0	0.000	0	0.000

## Statistics Configuration

All the statistics grids in the current lane will use these settings.

➤ **To get to this screen:**

1. From the Lane or Sensor Overview screen, click the Tools button  to see the Tools menu.
2. Choose Lane Setup, then Statistics Configuration.

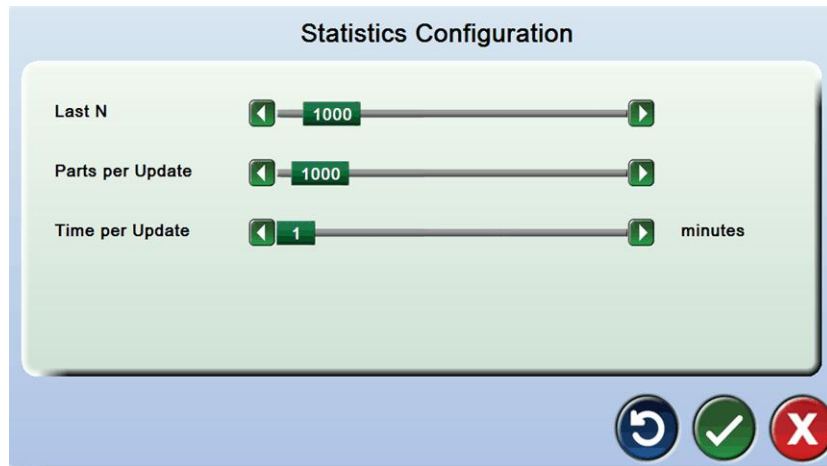

### Last N

Specify how many parts to include in recent statistics, such as the column "Last N" which displays the number of defects in the Last N parts, or "Last N %" which displays the percentages of defects within the Last N parts.

This feature allows you to continue to collect inspection data (Total inspected, total defects, and defect %) without clearing the statistics to see how the most recent batch of parts has done.

### Parts per Update

Determines the graduations on the horizontal axis for the Trend Chart and Timing Trend if "Parts" is selected.

### Time per Update

Determines the graduations on the horizontal axis on the Trend Chart and Timing Trend if "Time" is selected.

## Statistics Grid options

To change what is displayed in the statistics grids, use the options menu. These settings are applied to all statistics grids, whether in the Lane Overview screen, or Sensor Overview screen. Right-click over any statistics grid to see the options. These are explained below.

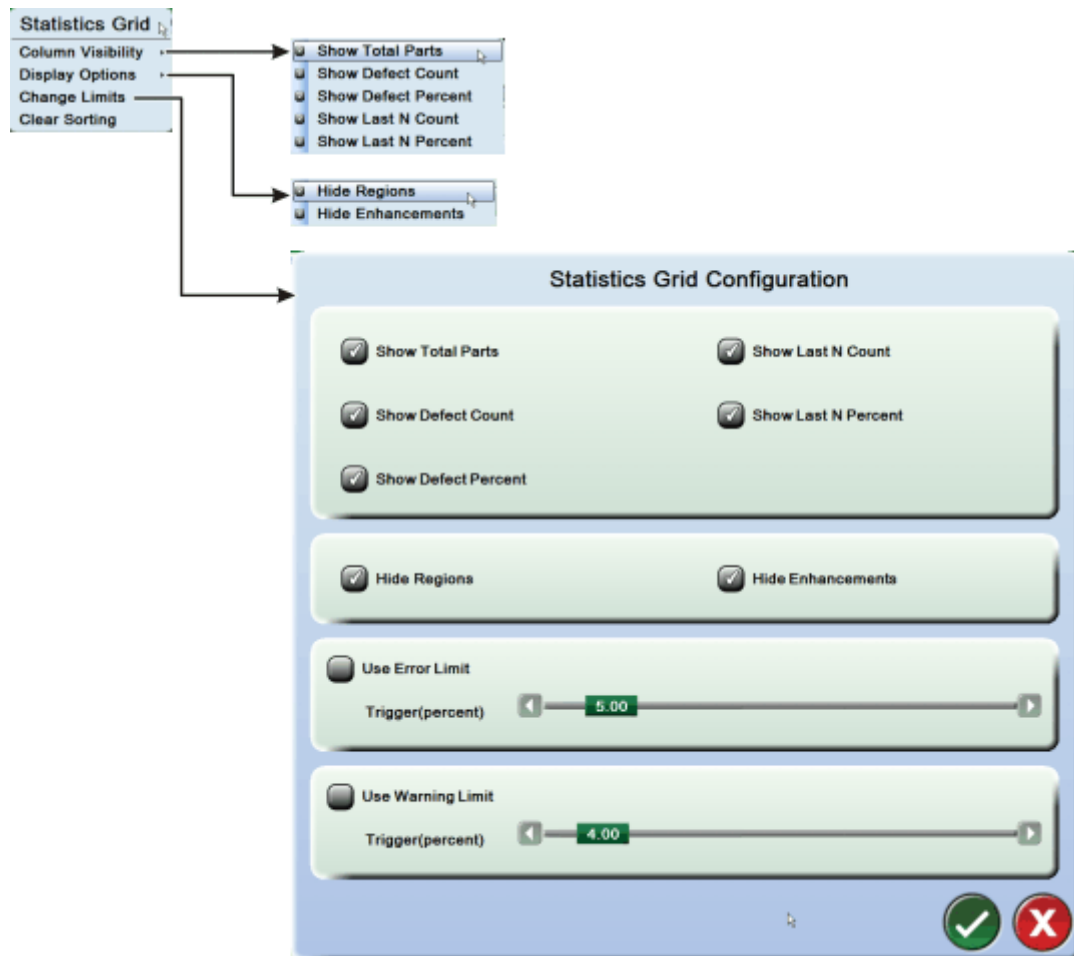

### **Column Visibility**

Change the number of columns that are displayed in the grid.

### **Display Options**

Change the number of rows that are displayed in the grid. This only affects the statistics grids in the Sensor Overview level.

### **Hide Regions**

If this is checked, then the inspection regions are not displayed in the grid. This means the Ring, Polygon, Rectangle, or Adaptive regions that identify the inspection area, but do not have any reject criteria.

### **Hide Enhancement**

If this is checked, then the inspection enhancements such as Clipping, Stretch Grayshades, or Power Filter are not displayed in the grid.

### **Change Limits**

This menu allows you to change the number of columns and rows of the grids in the first two sections of the menu. These are the same as Column Visibility and Display Options.

The lower two sections of this menu allow you to enable and change limits for inspection.

### Use Error Limit

Causes the **Defect %** and **Last N %** columns to display in red if the trigger percentage is exceeded. This allows you to see these statistics from a distance.

### Use Warning Limit

Causes the **Defect %** and **Last N %** columns to display in yellow if the trigger percentage is exceeded. This allows you to see these statistics from a distance.

### Clear Sorting

Puts the sorting order back to the default setting. To sort any column in ascending or descending order, click the button at the top of the column. Click it again to toggle to the opposite order.

---

## Big Live Image

### Big Live Image

Click the Big Live Image button in Sensor Overview mode to view an enlarged image of the last part that was inspected.

This image is updated when the lane is online and the camera is snapping images. The image is outlined in green if the part is passing, yellow if it is in a warning state, or red if the part is failing. You can view this image from a distance to quickly see how the inspection process is performing.



# Chapter 8

## Alarms

There are three levels of alarms within the Intellispec system: System, Lane, and Sensor alarms. Most of these are configurable. The table below lists the alarms, possible causes for triggering the alarm, the reset mechanism, and color of the indicator on the light tree. Also refer to the **light tree status** (on page 302) for more information about the lights.

The information in this section is valid as of software version 5.0.501.

❖ *Note: Alarms are recorded in the system log reader (on page 90), even when the alarms are automatically cleared.*

Alarm Name	Cause	Reset Mechanism	Color in light tree
<b>System Alarms (see "System Alarms Description" on page 76)</b>			
<b>Note:</b> If a system alarm occurs, an alarm icon is displayed in the lower right of the screen (in the Windows system tray)			
UPS	Battery is dead. Or:	Manually [you must first replace battery]	Not applicable (N/A)
	Plant power is lost and the UPS shutdown time is exceeded. The Intellispec shuts down.	If plant power is restored before the Intellispec shuts down, then the alarm condition is automatically cleared. Otherwise, you must restart the system manually.	N/A
Over temperature	CPU temperature exceeds highest recommended operating temperature. The Intellispec system shuts down. You must wait till the processor cools before resuming operation.	Manually	N/A
Lost network connection	If the plant network is configured to communicate with the Intellispec and the network connection is lost, a lost network icon appears in the Windows system tray	Restoring plant network connection	N/A
<b>Lane Alarms (see "Lane Alarms Description" on page 79)</b>			
Percent Defects <sup>1</sup>	Percentage of defects exceeds the set limit	Manually	Red

Alarm Name	Cause	Reset Mechanism	Color in light tree
Offline <sup>1</sup>	Lane goes offline	Manually	Green when system is online Red when system goes offline
Chute Full <sup>1</sup>	Reject chute is full	Manually [you must first clear chute]	Red
Blow Molder Door Open <sup>1</sup>	Blow molder door is open	Automatically [by closing blow molder door]	Red
Power Status <sup>1</sup>	Lane AC Power is lost	Automatically	Off when AC power is lost Blue when power is OK
Good Parts <sup>1</sup>	Used as a part counter. When specified number of parts is reached, then alarm is triggered.	Manually	Red
Missed Reject <sup>1</sup>	System missed rejecting a part. Works with <b>Reject Confirm</b> (see " <b>Reject Confirm Calibration (Optional)</b> " on page 120).	Manually	Red
System Error <sup>1</sup>	Part tracker or other internal system errors	Manually	Red
<b>Sensor Alarms (see "Sensor Alarms Description" on page 83)</b>			
Percent Rejects <sup>1</sup>	Percentage of rejected parts exceeds the set limit	Manually	Red
Excessive Rejects <sup>1</sup>	Excessive number of rejects	Manually	Red
Excessive Warnings <sup>1</sup>	Excessive number of warnings	Manually	Amber
Consecutive Defects <sup>1</sup>	Too many consecutive defects	Manually	Red
System Error <sup>1</sup>	Missed part, missed acquisition, missed result, or other internal error	Manually	Red

<sup>1</sup> If you want to connect an external monitoring device such as a PLC, an optional **Extended I/O** (on page 337) board is required for each lane.

## Viewing and Clearing Alarms

Use the View/Clear Alarms menu to see which alarms are enabled and disabled. A green light indicates that the alarm has not been triggered, while a red light indicates the alarm has been triggered.

➤ **To get to the View/Clear Alarms menu:**

- Click an Alarm button . The View/Clear Alarms menu is displayed.

**Or:**

1. View the Lane Overview or Sensor Overview screen by clicking either a Lane n button or Sensor button.

2. Click the Alarms button  to view the Alarms menu.
3. Select View/Clear Alarms from the menu. The menu shown below is displayed.

➤ **To view when an alarm was triggered and who last cleared it:**

Click an LED in the View/Clear Alarms screen.



➤ **To clear an alarm:**

- Click the Clear button next to any alarm to clear a single alarm. Or:
- Click the Clear All button at the bottom of the screen to clear all alarms.

❖ *Note: some triggered alarms may be from another sensor - click the red sensor indicator [in item 1] to see that sensor's alarms*

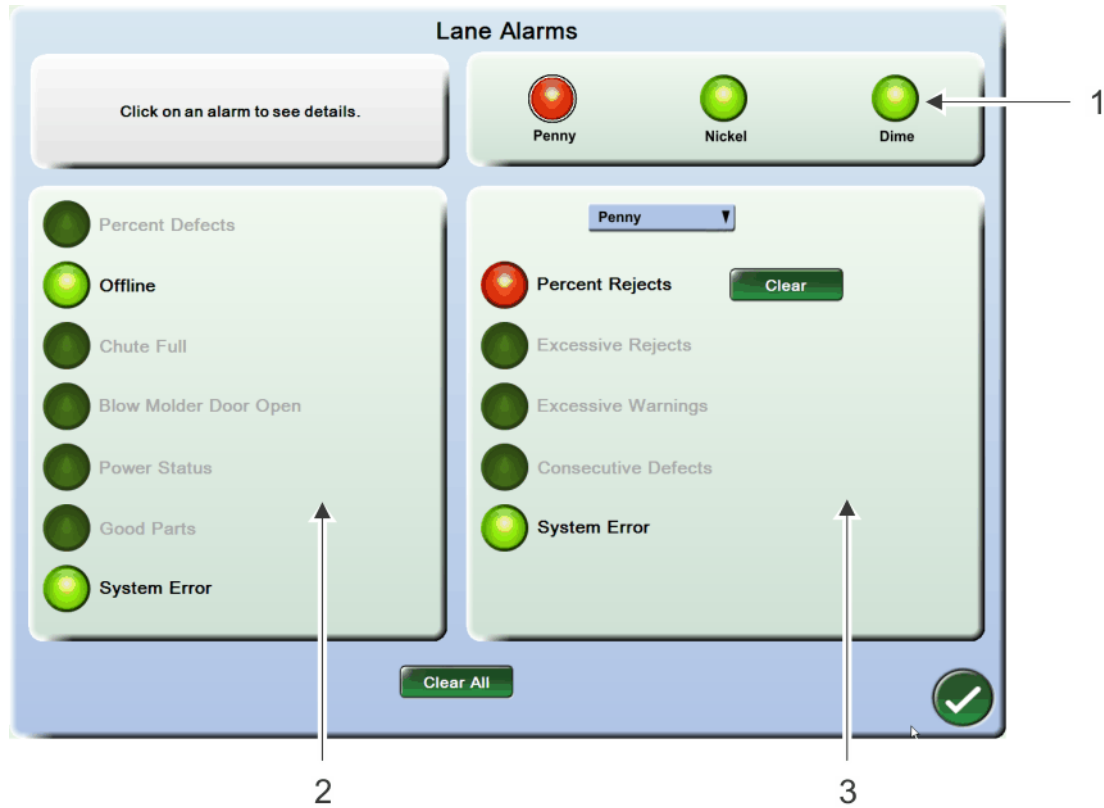



1	List of sensors in the selected lane. Click an LED to select a sensor.
2	List of Lane alarms
3	List of Sensor alarms. Use the drop-down menu to select a sensor.

❖ *Note: The LED with a white circle around it in the list of sensors [item 1] is the selected sensor. The drop-down menu also indicates the selected sensor.*

The indicators in this screen show whether an alarm is enabled, and whether it is triggered.



	Green Off - the alarm is not enabled nor triggered
---	--

	Green On - the alarm is enabled, but has not been triggered
	Red On - the alarm is both enabled and triggered

## System Alarms Description

The system alarms are the UPS (uninterruptible power supply) and CPU temperature alarms. You can configure the UPS shut down time.

➤ **To get to this menu:**

1. Click the Home button  to view the System Overview screen.
2. Click the Alarms button  to view the system alarms. The screen shown below is displayed.

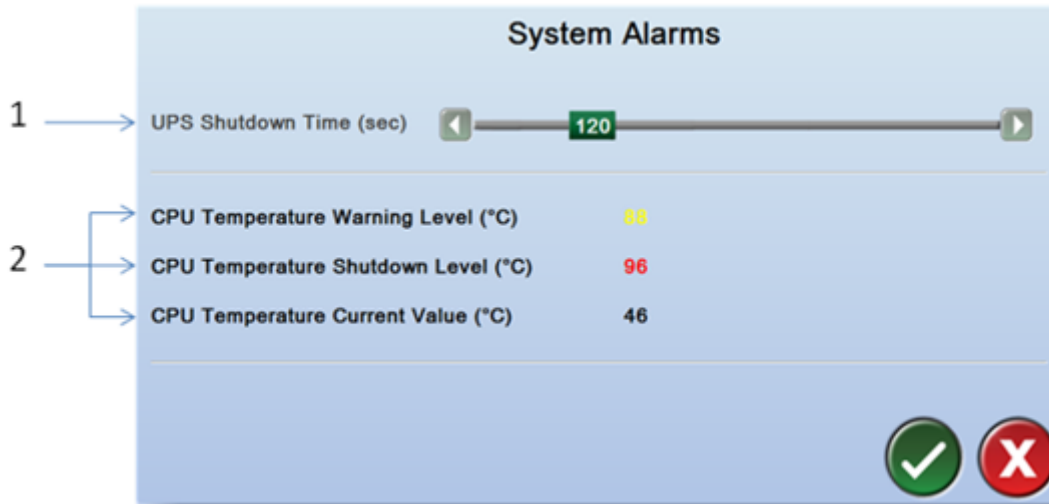

1	UPS Shutdown Time – Set the number of seconds that the UPS will maintain power to the system if AC power has been lost. The Intellispec system shuts down after this time period. This allows for a normal Windows shutdown.
2	CPU Temperature – Displays the current, warning, and shutdown temperatures associated with the computer CPU. If a multiple core computer is used, the highest temperature is displayed. If the shutdown CPU temperature is reached, the Intellispec system shuts down.

## Lane Alarm Configuration

In the Lane Alarm Configuration menu, you can edit alarms for an entire lane. To see a description for each type of alarm, see **Lane alarms description** (on page 79).

❖ *Note: Some menu items are only available to advanced level users.*

➤ **To get to this menu:**

1. Log in.
2. View the Lane Overview screen by clicking a Lane n button.
3. Click the Alarms button  to view the Alarms menu.

4. From the Alarms menu, select Lane Alarm Configuration.

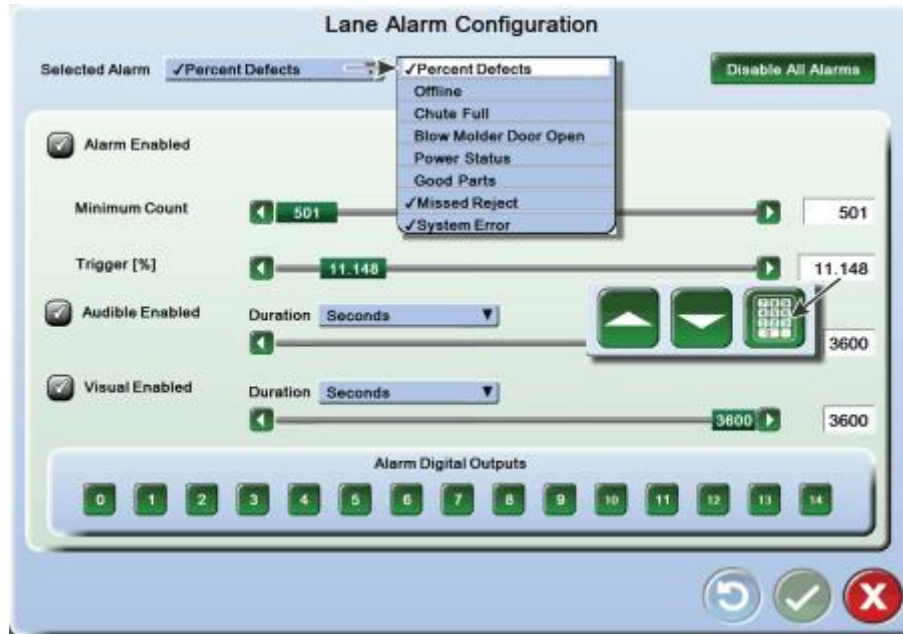

Select an alarm from the drop-down menu to configure that alarm. You can enable or disable parameters for each alarm individually. A check mark appears in the box next to the parameter, and the name of the alarm, when it is enabled. The parameters are described below.

For numeric values, you can change the numbers with the slider bars or click in the box to the right of the slider to nudge the number up or down, or bring up a numeric keypad to enter a new value.

#### Alarm Enabled

Enables alarm.

#### Minimum Count

Specify the minimum number of parts that must be inspected before the alarm can be triggered. This prevents the alarm from being triggered too soon, when only a small number of parts may make the statistics trigger the alarm.

Minimum Count is used in the **Percent Defects** alarm.

#### Trigger [%]

Define the percentage of parts inspected that must fail to trigger the Percent Defects alarm. This number is selectable between zero and 100. The default value is five percent.

Trigger [%] is used in the **Percent Defects** alarm.

❖ *Note: you can change this percentage in the **Trend Charts** (see "**Alarm Percentages in Trend Charts**" on page 64) in Lane Overview mode when Defect % is selected for the V-axis.*

#### Trigger (thousands)

[Good Parts alarm] The number of parts that must pass inspection to trigger the alarm. The number is expressed in thousands.

#### Audible Enabled

If this parameter is enabled, the audible alarm will sound when triggered.

#### Audible Duration

The number of seconds the audible alarm will sound if triggered. It will remain on until the alarm is cleared. Use the slider to set values up to 3600 seconds (60 minutes), or use the drop-down menu option to allow the alarm to remain on forever (until cleared).

#### Visual Enabled

If this parameter is enabled, this alarm will switch on the appropriate light on the light tree when triggered.

## Visual Duration

The number of seconds the light will remain on when the alarm is triggered. It will remain on until the alarm is cleared. Use the slider to set values up to 3600 seconds (60 minutes), or use the drop-down menu option to allow the alarm to remain on forever (until cleared).

## Alarm Outputs

Select an output (**Inspection Alarm 0-14**) to be toggled on the optional **Extended I/O** (see "**Extended I/O board**" on page 337) kit when the alarm is triggered.

❖ *Note: if your system has firmware version F168 or higher, there are 16 Alarm Digital Outputs. They are numbered 0-15. Firmware versions below F168 support 15 Alarm Digital Outputs numbered 0-14.*

- There are 15 available **Inspection Alarm** outputs that correspond to the **extended I/O signals** (on page 338). Click one of the output numbers to assign the current alarm to an output.
- These outputs go active when the alarm is triggered, and go inactive when the alarm is cleared.
- The outputs can be monitored by your plant equipment, such as a PLC, to notify you when certain alarms are triggered.

## Disable All Alarms

Click this button to disable all the current alarms at once. This disables only the alarms for the current sensor or lane. This is used in emergencies when you cannot repair a situation immediately, or when setting up the system. The remaining parameter settings for each alarm are saved for future use. You must re-enable each alarm individually when you are ready.

## Missed Reject and System Error Alarm Details

The Missed Reject and System Error Alarms cannot be disabled. However, there is a **Details** button that shows whether they are being used as an alarm (to light the red light of the light tree, turn on the horn, or turn on the audible alarm). Alarms may be added or subtracted from the software without notice.



### Use as Alarm

This is the normal setting.

### Count Only

If one or more of the System Error alarms have Count Only selected, then those alarms will be used as a warning. In the View/Clear Alarms screen, the LED will be yellow if the alarm is triggered (instead of red). The Count Only alarms will NOT light any light in the light tree, sound the horn, nor cause the red flashing ALARM button over the Lane button.

❖ *Note: We do not recommend using Count Only for any of the System Error alarms, unless the system has a problem where a specific alarm is frequently triggered and thus overshadows other alarms.*

Click the OK button  to apply changes and exit the menu.

---

# Lane Alarms Description

The available Lane alarms are as follows:

## Percent Defects

This alarm is triggered when the percentage of defective parts from a Lane exceeds the Percent Trigger. It will remain triggered until you clear the alarm. It uses the red light of the light tree as a visual indicator.

## Offline

This alarm indicates whether the system is online or offline. The green light of the light tree is on when the system is online. The green light turns off and the red light turns on when the system goes offline.

## Chute Full

This alarm is mainly used in systems that have inspection modules installed within a blow molder, and use the blow molder's internal reject chute. It is triggered when the blow molder's internal reject chute is full. This alarm may not apply to your system. It uses the red light of the light tree as a visual indicator.

If this alarm is enabled and triggered, the blow molder's internal rejector will be disabled, thus not allowing any more defective parts to be rejected. The rejector will remain disabled until you clear the chute and then clear the alarm from the alarms tab. If you clear the alarm without clearing the chute, the alarm will be triggered again.

❖ *Note: This alarm is disabled when the Intellispec is offline.*

## Blow Molder Door Open

This alarm is used for systems that have inspection modules installed within a blow molder. It is triggered when the blow molder door is opened. It will remain triggered until the door is closed. It uses the red light of the light tree as a visual indicator. This alarm may not apply to your system.

❖ *Note: In PET Preform applications, this alarm is triggered when the Bypass Gate opens.*

## Power Status

This alarm is triggered when Lane AC power is lost. It remains triggered until AC power is restored. If AC power remains off for an extended period of time, the system will shut down.

The red light of the light tree will switch on when Lane AC power is lost. The blue light should remain on as long as the Lane power is on.

## Good Parts

This alarm can be used as a part counter. For example, say you are inspecting preforms, and have a box at the end of the conveyor (after inspection) that holds 5000 preforms. This alarm will count the number of good inspected parts, and notify you when 5000 good parts have reached that box. The Alarm Output through the optional Extended I/O can be used to stop the conveyor from moving parts into the inspection system. You can then install a new box at the end of the conveyor, reset this alarm, and start counting the next 5000 parts.

This alarm is triggered when a number of good inspected parts [Trigger (thousands)] has been reached. It will remain triggered until you clear the alarm. It uses the red light of the light tree as a visual indicator. Note that clearing this alarm also clears the Good Parts count.

See also information about the optional **Extended I/O** (see "**Extended I/O board**" on page 337) module.

## Missed Reject

This alarm works in conjunction with **Reject Confirm** (see "**Reject Confirm Calibration (Optional)**" on page 120). It is triggered when a missed reject occurs. It uses the red light of the light tree as a visual indicator. There will be two Missed Reject alarms available if two **rejectors** (see "**Rejector Enable/Disable**" on page 103) are enabled and two **Reject Confirm rejectors** (see "**Reject Confirm Calibration (Optional)**" on page 120) are enabled.

## System Error

System Error is a group of several internal system alarms. Click the System Error LED on the Lane Alarms screen to see all the alarms and their statuses. See also **Lane Alarm Configuration** (on page 76) to see how this alarm is configured.

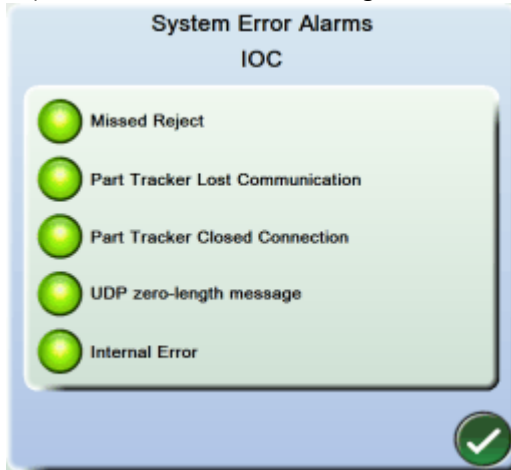

These errors are recorded in the **Log Reader** (on page 90). Some of these are described below. Other system error alarms may be added and shown on the screen, or removed without notice.

- **Part Tracker Lost Communication** - You may be able to reset the Part Tracker to re-establish communication. See Resetting the Part Tracker Board in FHCP 3X.
- **Internal Error** - an internal error was logged. This usually requires Pressco technical assistance.

---

## Sensor Alarm Configuration

In the Sensor Alarm Configuration pop up window, you can edit alarm settings for an entire Sensor. To see a description of each type of alarm, see **Sensor alarms description** (on page 83).

❖ *Note: Some menu items are only available to advanced level users.*

### ➤ *To get to this menu:*

1. Log in.
2. View either the Lane Overview or Sensor Overview screen by clicking a Lane n or Sensor n button.
3. Click the Alarms button  to view the Alarms menu.
4. From the Alarms menu, select Sensor Alarm Configuration.

- Choose a sensor to configure. You must configure each sensor separately.

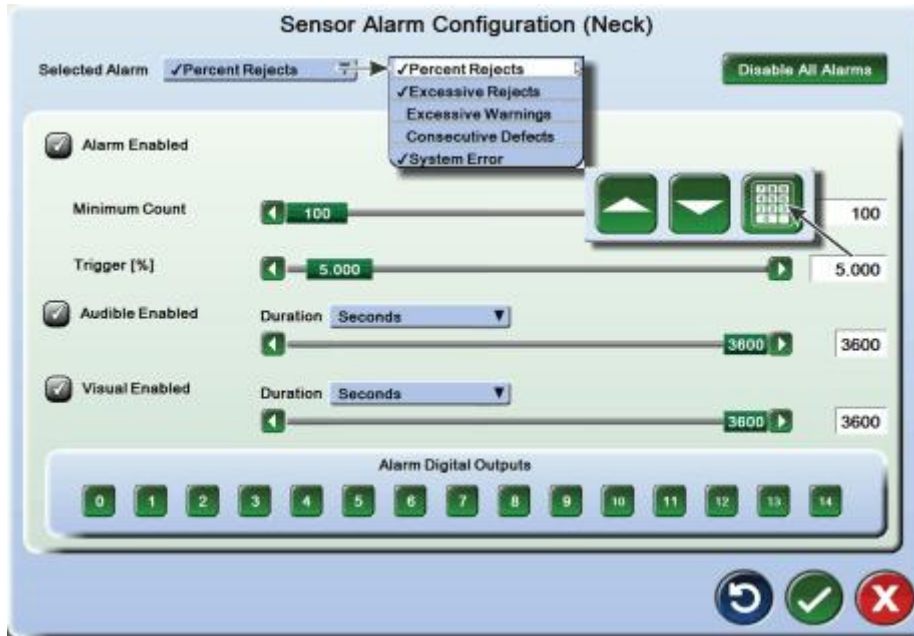

Select an alarm from the drop-down menu to configure that alarm. You can enable or disable parameters for each alarm individually. A check mark appears in the box next to the parameter, and the name of the alarm, when it is enabled. The parameters are described below.

For numeric values, you can change the numbers with the slider bars or click in the box to the right of the slider to nudge the number up or down, or bring up a numeric keypad to enter a new value.

#### Alarm Enabled

Enables alarm.

#### Minimum Count

Specify the minimum number of parts that must be inspected before the alarm can be triggered. This prevents the alarm from being triggered too soon, when only a small number of parts may make the statistics trigger the alarm.

Minimum Count is used in the **Percent Rejects** alarm.

#### Sample Size

Define the number of parts that must be inspected to determine the excessive warning percentage. This number is selectable between one and 100,000. The default value is 100. This is a sliding window: for example assume Sample Size = 1,000 and Percent Trigger = 3. If three percent of the last 1000 parts have had a warning status, the alarm is triggered.

Sample Size is used in the **Excessive Rejects** and **Excessive Warnings** alarms.

#### Trigger [%]

Define the percentage of parts inspected that must fail to trigger the Percent Defects alarm. This number is selectable between zero and 100. The default value is five percent.

Trigger [%] is used in the **Percent Rejects**, **Excessive Rejects**, and **Excessive Warnings** alarms.

❖ *Note: you can change this percentage in the **Trend Charts** (see "**Alarm Percentages in Trend Charts**" on page 64) in **Sensor Overview** mode when **Defect %** is selected for the V-axis.*

#### Consecutive Triggers

Define the number of defects in a row that the system must have to trigger the alarm. This number is selectable between two and 100. The default value is 25.

Consecutive Triggers is used with the **Consecutive Defects** alarm.

#### Audible Enabled

If this parameter is enabled, the audible alarm will sound when triggered.

### Audible Duration

The number of seconds the audible alarm will sound if triggered. It will remain on until the alarm is cleared. Use the slider to set values up to 3600 seconds (60 minutes), or use the drop-down menu option to allow the alarm to remain on forever (until cleared).

### Visual Enabled

If this parameter is enabled, this alarm will switch on the appropriate light on the light tree when triggered.

### Visual Duration

The number of seconds the light will remain on when the alarm is triggered. It will remain on until the alarm is cleared. Use the slider to set values up to 3600 seconds (60 minutes), or use the drop-down menu option to allow the alarm to remain on forever (until cleared).

### Alarm Outputs

Select an output (**Inspection Alarm 0-14**) to be toggled on the optional **Extended I/O** (see "**Extended I/O board**" on page 337) kit when the alarm is triggered.

❖ *Note: if your system has firmware version F168 or higher, there are 16 Alarm Digital Outputs. They are numbered 0-15. Firmware versions below F168 support 15 Alarm Digital Outputs numbered 0-14.*

- There are 15 available **Inspection Alarm** outputs that correspond to the **extended I/O signals** (on page 338). Click one of the output numbers to assign the current alarm to an output.
- These outputs go active when the alarm is triggered, and go inactive when the alarm is cleared.
- The outputs can be monitored by your plant equipment, such as a PLC, to notify you when certain alarms are triggered.

### Disable All Alarms

Click this button to disable all the current alarms at once. This disables only the alarms for the current sensor or lane. This is used in emergencies when you cannot repair a situation immediately, or when setting up the system. The remaining parameter settings for each alarm are saved for future use. You must re-enable each alarm individually when you are ready.

## System Error Alarm Details

The System Error Alarm cannot be disabled. However, there is a **Details** button that shows whether it is being used as an alarm (to light the red light of the light tree, turn on the horn, or turn on the audible alarm). Alarms may be added or subtracted from the software without notice.

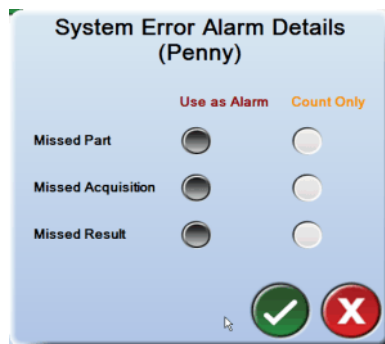

### Use as Alarm

This is the normal setting.

### Count Only

If one or more of the System Error alarms or Missed Reject have Count Only selected, then those alarms will be used as a warning. In the View/Clear Alarms screen, the LED will be yellow if the alarm is triggered (instead of red). The Count Only alarms will NOT light any light in the light tree, sound the horn, nor cause the red flashing **ALARM** button over the Lane button.

❖ *Note: We do not recommend using Count Only for any of these alarms, unless the system has a problem where a specific alarm is frequently triggered and thus overshadows other alarms.*

Click the OK button  to apply changes and exit the menu.

## Sensor Alarms Description

The available Sensor alarms are as follows:

❖ *Note: parameters, such as Percent Trigger, are adjusted in the **Sensor Alarm Configuration** (on page 80).*

### Percent Rejects

This alarm is triggered when the total percentage of defects for the current sensor exceeds a defined percentage. This percentage is defined with the Trigger [%] parameter. It will remain triggered until you clear the alarm. It uses the red light of the light tree as a visual indicator.

### Excessive Rejects

This alarm is triggered when a percentage of the last  $n$  parts have been found defective. It will remain triggered until you clear the alarm.  $n$  = Sample Size. The percentage is defined with the Trigger [%] parameter. It uses the red light of the light tree as a visual indicator.

### Excessive Warnings

This alarm is triggered when a percentage of the last  $n$  parts have been found with a warning status. It will remain triggered until you clear the alarm.  $n$  = Sample Size. The percentage is defined with the Trigger [%] parameter. It uses the amber light of the light tree as a visual indicator.

Warnings are enabled in the **Retro-Spec Options** (on page 187) when you are editing an inspection.

### Consecutive Defects

This alarm is triggered when the sensor has had too many consecutive defects. The number of defects is defined by the Consecutive Triggers parameter. It will remain triggered until you clear the alarm. It uses the red light of the light tree as a visual indicator.

### System Error

System Error is a group of several internal system alarms. Click the System Error LED on the right side of the View/Clear Alarms screen to see all the alarms and their statuses. See also **Sensor Alarm Configuration** (on page 80) to see how this alarm is configured. Alarms may be added or subtracted from the software without notice.



These errors are recorded in the **Log Reader** (on page 90).

- **Missed Part** - No current function.
- **Missed Acquisition** - This alarm is triggered if the sensor misses acquiring the image of a part. For example, the inspection time was too high, or the part was too deformed to properly detect. It will remain triggered until you clear the alarm. It uses the red light of the light tree as a visual indicator. See also **Sequence of Events** (see "**Sequence of Events During Inspection**" on page 168).

- **Missed Result** - This alarm is triggered if the sensor misses the inspection results of a part. For example, the inspection time was too high, or the processor was too busy to process the inspection results before the part reached the reject position. It will remain triggered until you clear the alarm. It uses the red light of the light tree as a visual indicator. See also ***Sequence of Events*** (see "***Sequence of Events During Inspection***" on page 168).



# Chapter 9

## Tools Menus

This section covers the tools menus that are available through System Overview or Lane/Sensor Overview modes.

### Tools menu - System Overview Screen

➤ *To view the Tools menu:*

1. Log in. (Some items may be grayed out if you do not have permissions to use the items)
2. Click the Home button  to view the System Overview screen.
3. Click the Tools button  to view the Tools menu.

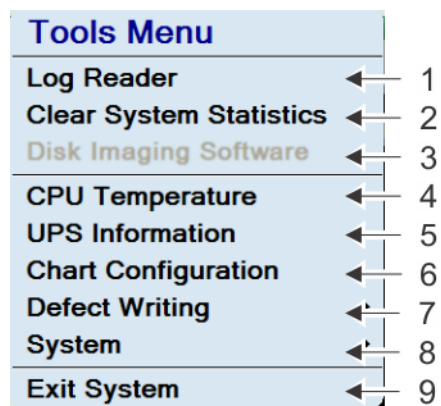

1	<b>Log Reader</b> (on page 90) – Open the Intellispec log
2	Clear System Statistics – Clear the entire system statistics (all Lanes)
3	Disk Imaging Software – Open Acronis Echo software for backing up system hard drive
4	CPU Temperature – Displays the current, warning, and shutdown temperatures associated with the computer CPU. If a multiple core computer is used, the highest temperature is displayed. If the shutdown CPU temperature is reached, the Intellispec system shuts down.
5	UPS Information – Display Uninterruptible Power Supply (UPS) information and settings
6	Chart Configuration – Choose the Trend Graph Type and the number of divisions for the horizontal axis for the chart displayed in the System Overview Screen
7	Defect Writing - [Only available if Defect Database option is installed and enabled] Enable or disable defect recording for multiple lanes.
8	System - Set system date and time or set up a printer
9	Exit System – Shut down Intellispec software

# Tools menu - Lane Overview and Sensor Overview Screens

The Tools menu is the same in both Lane Overview and Sensor Overview screens.

➤ **To view the Tools menu:**

1. Log in. (Some items may be grayed out if you do not have permissions to use the items)
2. Click a Lane *n* button to view the Lane Overview screen.
3. Click the Tools button  to view the Tools menu.

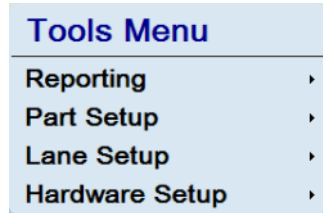

**Reporting** (on page 86)

**Part Setup** (on page 91)

**Lane Setup** (on page 94)

**Hardware Setup** (on page 108)

## Reporting

The Intellispec generates many different reports to provide inspection detail. Many of these reports can be transferred outside of the Intellispec.

❖ *Note: Some menu items are only available to advanced level users.*

➤ **To view reports:**

1. View the Lane Overview screen by clicking a Lane *n* button.
2. Click the Tools button  to view the Tools menu.
3. From the Tools menu select Reporting, then select your desired option. These are described below.

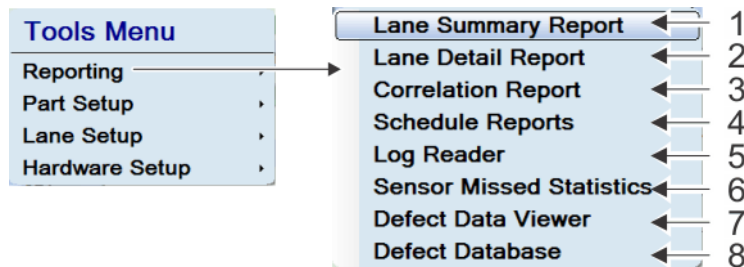

1	<b>Lane Summary Report</b> (on page 87) - Generate a summary of the statistics for the current lane.
2	<b>Lane Detail Report</b> (on page 88) - Generate a report with the lane and sensor defect statistics broken down to inspection-by-inspection data.
3	Correlation Report - (Only available if correlation is enabled on your system) Generate a report with the percentage of defects by machine part
4	<b>Schedule Reports</b> (on page 88) - Define the frequency and destination for automatic statistics reporting.
5	<b>Log Reader</b> (on page 90) – Open the Intellispec log
6	<b>Sensor Missed Statistics</b> (on page 91) - Display the number of missed parts for the lane.

7	Defect Data Viewer - [Only shown if this option is enabled] View the images in the defect database
8	Defect Database - [Only shown if this option is enabled] View the inspection data and reports from the defect database

## ***Lane Summary Report***

This report lists the statistics summary for the lane, including:

- Number of parts inspected
- Number of defects
- Defect percentage

The above numbers are reported per sensor, and as an overall number for the lane. An example from a one lane system is shown below.

```

myReport.txt - Notepad
File Edit Format View Help
Lane Summary:
Machine Name: INTELLISPEC_1234
Part Program: My Part Program
Current Time: 12/23/2010 3:53:46 PM
Last Reset: 12/23/2010 3:53:02 PM
Sensor          Parts   Defects  Defect %
Sensor 1        149     147     98.658
Sensor 2        149     146     97.987
Sensor 3        149      0      |0.000
Overall         149     147     98.658

```

## Lane Detail Report

This report contains all the information in the **Lane Summary Report** (on page 87), plus inspection detail for each sensor with the number of defects found by each inspection. An example is shown below.

mySummary.txt - WordPad

Lane Summary:

Machine Name: INTELLISPEC\_1234  
Part Program: MyPartProgram  
Current Time: 12/23/2010 3:54:39 PM  
Last Reset: 12/23/2010 3:53:02 PM

Sensor	Parts	Defects	Defect %
Sensor 1	149	147	98.658
Sensor 2	149	146	97.987
Overall	149	147	98.658

Machine Name: INTELLISPEC\_1234  
Part Program: MyPartProgram  
Current Time: 12/23/2010 3:54:39 PM  
Last Reset: 12/23/2010 3:53:02 PM

Sensor 1 :

Inspection	Parts	Defects	Defect %
Ring	149	0	0.000
Measurement	149	147	98.658
Ambient	149	0	0.000
Contrast	149	147	98.658
Polygon	149	0	0.000
Centerline	149	147	98.658
Adaptive	149	147	98.658
Ring	149	0	0.000
Ambient	149	0	0.000
Measure Extract	149	57	38.255
Distance	149	147	98.658
Overall	149	147	98.658



Sensor 2 :

Inspection	Parts	Defects	Defect %
Polygon	149	0	0.000
Centerline	149	146	97.987
Overall	149	146	97.987

## Schedule Reports

Set up a schedule where the Intellispec generates reports automatically. This is a Lane-level setting. To schedule reports for more than one lane, you must repeat the process for each lane.

➤ **To schedule reports:**

1. Go to the Lane Overview screen by clicking a Lane n button.
2. Click the Tools button  to view the Tools menu.
3. From the Tools menu, select Reporting, then select Schedule Reports. The screen shown below is displayed.
4. Change the settings as desired. These are described below.
5. Click the OK button  to save changes and exit the screen.

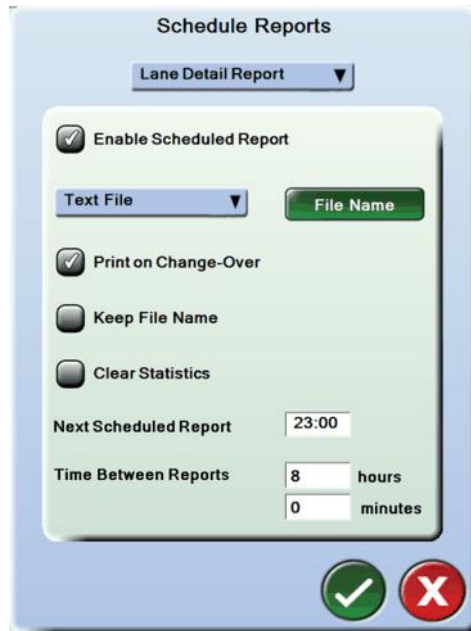

### **Report drop-down menu**

Select which report to schedule, then change the settings in the menu. Each report must be set up separately.

See also **Lane Summary Report** (on page 87) and **Lane Detail Report** (on page 88).

### **Report settings**

#### **Enable Scheduled Report**

Choose whether to schedule the selected report. When this box is checked, the settings below are active.

#### **Destination drop-down menu**

Choose whether to send the report to the default printer or a file. When Text File is selected, you can enter a file name by clicking the **File Name** button.

If you do not name the file, then the file is named "PresscoReportnn.txt" where nn is the number of the next generated report. It is saved at the hard disk location "c:\Pressco." Subsequently saved reports overwrite the file.

#### **Print on Change-Over**

Schedule the system to generate a report if someone changes a part program. This contains defect statistics from the time of the last statistics reset until the time that the part change-over occurred. See Change-over Report Example.

#### **Keep File Name**

When a report is printed to file and this feature is enabled, the system will write the inspection statistics to the same file name each time, rather than creating new files with unique names. The system overwrites the file each time. You will need to click the **File Name** button, browse to the location where you want to save it, and create a name for your report.

An example of where this feature might be used is a plant where the Intellispec is networked. Say the office computer is programmed to poll the Intellispec at regular intervals to get the latest statistics report. With the same file name, the office computer just needs to request the same file name each time, regardless of the date and time the report was saved.

### Reset Statistics

The Lane statistics are cleared after each print.

### Next Scheduled Report

Using a 24 hour clock, set the time when the Intellispec should save or print the next report.

### Time Between Reports

Set the time interval when the Intellispec should save or print the following reports. This interval is used after the Next Scheduled Report, and is repeated the set number of hours and/or minutes thereafter.

## Log Reader

The log reader displays the Intellispec event history including:

- User log in and log out information
- Part program changes

❖ *Note: detailed part program changes are found in the **Part Program Change Log** (on page 174)*

- Alarms, when triggered and cleared
- System errors
- System starting information
- Lane online/ offline history
- Lighting changes

Text files of the logs are stored at: C:\Pressco\Logs.

Date	Time	Lane	Message	User	Online	Part Program	
Tue	2011-11-22	17:03:05	(2) Nickle	System went offline.	Administrator	Offline	Nickel
Tue	2011-11-29	09:27:47	(0) System	System process starts.	Administrator	Offline	default
Tue	2011-11-29	09:28:18	(0) System	Internal Error	Administrator	Offline	default
Tue	2011-11-29	09:28:31	(4) Quarter	Lane process starts.	Administrator	Offline	Measurement_test
Tue	2011-11-29	09:28:31	(4) Quarter	Version: 5.0.467 (XP, 32 bit)	Administrator	Offline	Measurement_test
Tue	2011-11-29	09:28:31	(4) Quarter	Built: 11/29/2011 3:29:07 PM	Administrator	Offline	Measurement_test
Tue	2011-11-29	09:28:31	(4) Quarter	Built by: dpaunescu	Administrator	Offline	Measurement_test
Tue	2011-11-29	09:28:31	(4) Quarter	Built on machine: DPOP755	Administrator	Offline	Measurement_test
Tue	2011-11-29	09:28:31	(4) Quarter	Built on operating system: Microsoft Windows NT 5.1.2600 Service...	Administrator	Offline	Measurement_test
Tue	2011-11-29	09:28:31	(4) Quarter	Build changed from '5.0.465 (XP, 32 bit)' to '5.0.467 (XP, 32 bit)'	Administrator	Offline	Measurement_test
Tue	2011-11-29	09:28:31	(2) Nickle	Lane process starts.	Administrator	Offline	Nickel
Tue	2011-11-29	09:30:20	(2) Nickle	Sensor 'Neck' with Id 2 in the part program 1L squat blue was not fou...	Administrator	Offline	Nickel
Tue	2011-11-29	09:30:20	(2) Nickle	Sensor 'Seal' with Id 3 in the part program 1L squat blue was not fou...	Administrator	Offline	Nickel
Tue	2011-11-29	09:30:20	(2) Nickle	Sensor 'Neck' with Id 2 in the part program .5L Snapple Clear was n...	Administrator	Offline	Nickel
Tue	2011-11-29	09:30:20	(2) Nickle	Sensor 'Seal' with Id 3 in the part program .5L Snapple Clear was no...	Administrator	Offline	Nickel
Tue	2011-11-29	09:30:22	(0) System	Was not able to connect to a UPS	Administrator	Offline	default
Tue	2011-11-29	09:30:41	(0) System	User 'Administrator' has logged in.	Administrator	Offline	default
Tue	2011-11-29	09:32:03	(2) Nickle	System went offline.	Administrator	Offline	Nickel
Tue	2011-11-29	09:41:35	(1) Penny	System went online.	Administrator	Online	Penny
Tue	2011-11-29	09:41:36	(1) Penny	System went offline.	Administrator	Offline	Penny

## Sensor Missed Statistics

Displays the number of missed parts and missed part tracking for the sensor.

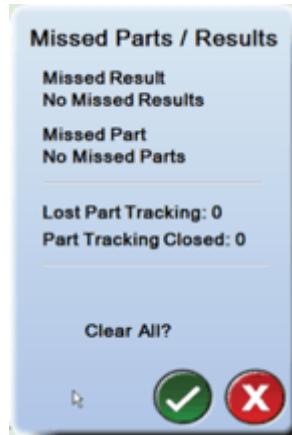

This information is recorded in the **Log Reader** (on page 90).

### Missed Results

This can occur if you set the **Reject Delay Calibration** (on page 113) incorrectly. Another cause could be kinks or intermittent connections to cables, or the inspection time for the lane is too long.

## Error messages

### Part Tracker Exception

If you see an error "Part Tracker Exception" on the Intellispec screen, this means that power was lost to the Cluster Box or Part Tracker.

#### ➤ **To reset the part tracker board:**

Push the **Reset** button on the part tracker board. This is found inside the inspection module or Cluster Box.

### Lost Part Tracking

If you see a "Lost Part Tracking" message, possibly the power was lost to the Cluster Box or Part Tracker inside an inspection module. Reset the Part Tracker board as described above.

## Part Setup

The Part Setup menu provides access to lighting, part display options in charts, and part width calibration.

Some menu items are only available to advanced level users.

### ➤ To view the Part Setup menu:

1. View the Lane Overview screen by clicking a Lane n button.
2. Click the Tools button  to view the Tools menu.
3. From the Tools menu select Part Setup >> then your desired option. These are described below.

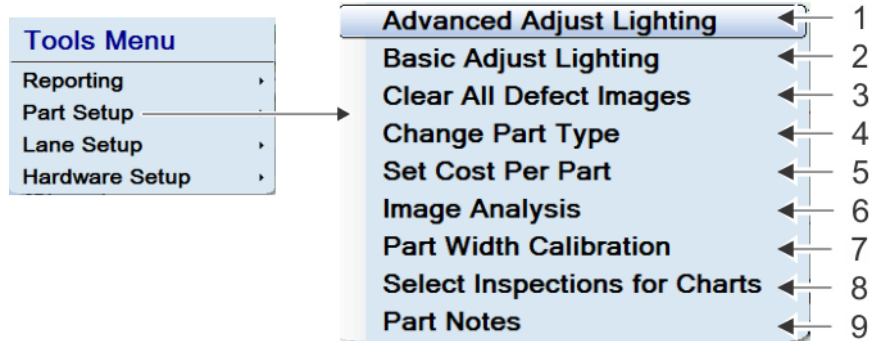

1	<b>Advanced Adjust Lighting</b> (on page 142)
2	<b>Basic Adjust Lighting</b> (on page 141)
3	Clear All Defect Images - Remove all images from the Reject Images buffer.
4	Change Part Type - Select the type of part to be displayed on the Walk By Graphic for the current lane.
5	Set Cost Per Part - Set the cost of each product, to be used with the "Defect Cost" trend chart.
6	<b>Image Analysis</b> (on page 138) - Determine the gray shade value for any pixel or group of pixels in your image.
7	<b>Part Width Calibration</b> (on page 92) - Set the number of encoder pulses that the part detect sensor "sees" the part.
8	Select Inspections For Charts - Select which inspections (up to 8) to display on the Trend Chart and Timing Trend.
9	Part Notes - Add setup and programming information about the part. This is especially helpful if you or someone else need to modify the part program later.

### Part Width Calibration



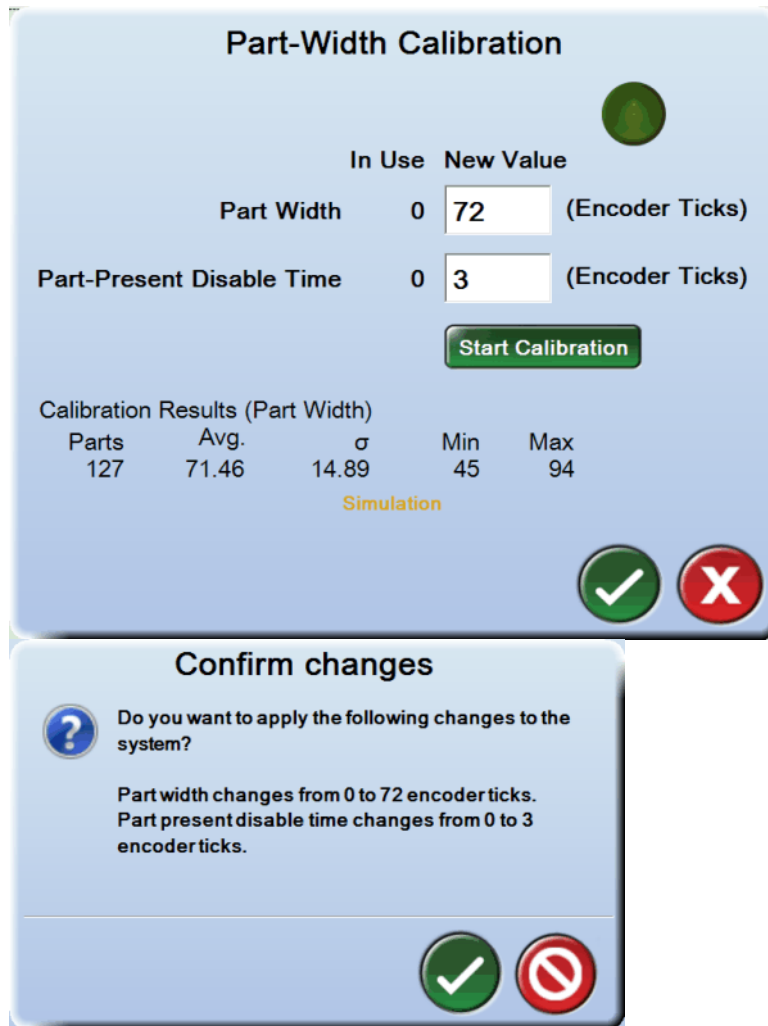

Part Width is the number of encoder pulses that the part detect sensor "sees" the part. To perform the calibration you must be running parts past the part detect sensor.

### ➤ To get to the Part Width menu:

1. From the Sensor Overview mode, right-click on a sensor button to view the **sensor menu** (on page 135).
2. Select Part Tracking, then select Part Width Calibration.



➤ **To calibrate the Part Width:**

1. With parts running under the camera or sensor, click **Start Calibration**. As each part goes by its part width will be displayed in Part Width field.
2. After a sufficient number of parts have gone by (we recommend about 10 parts), click **Stop Calibration** (same button as Start Calibration). This will display the calibration results in the lower part of the screen.
3. Examine the results; look for the **minimum** and **maximum** values to be within approximately 10 encoder pulses of each other. If the results are acceptable click OK  to save the data. If the results are skewed, recalibrate the part width. To exit without saving the changes, click the exit  button.
4. The system will prompt you to confirm your changes. If the results are acceptable click OK  to save the data. If the results are skewed, click the cancel  button and recalibrate.

## Part Rate

In Intellispec systems with software version 5.0.440 and later, the part rate is displayed in Lane Overview and Sensor Overview modes.

You can reset the part rate by right-clicking over the part rate tab and clicking **Reset Part Rate**.

The part rate displays:

- ppm (parts per minute)** - The average rate over the last five seconds. It is updated once per second.
- max** - The maximum rate found for all individual parts in the last five seconds determined in [a]. The displayed value is the largest value found in the last five minutes.

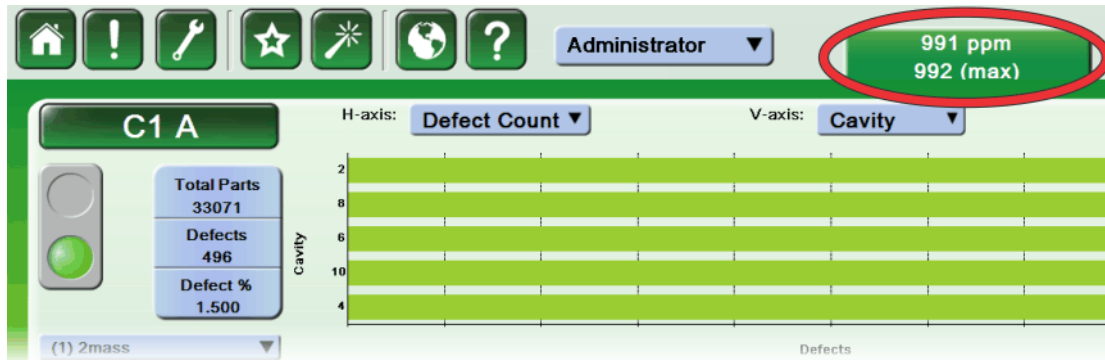

## Lane Setup

Some menu items are only available to advanced level users.

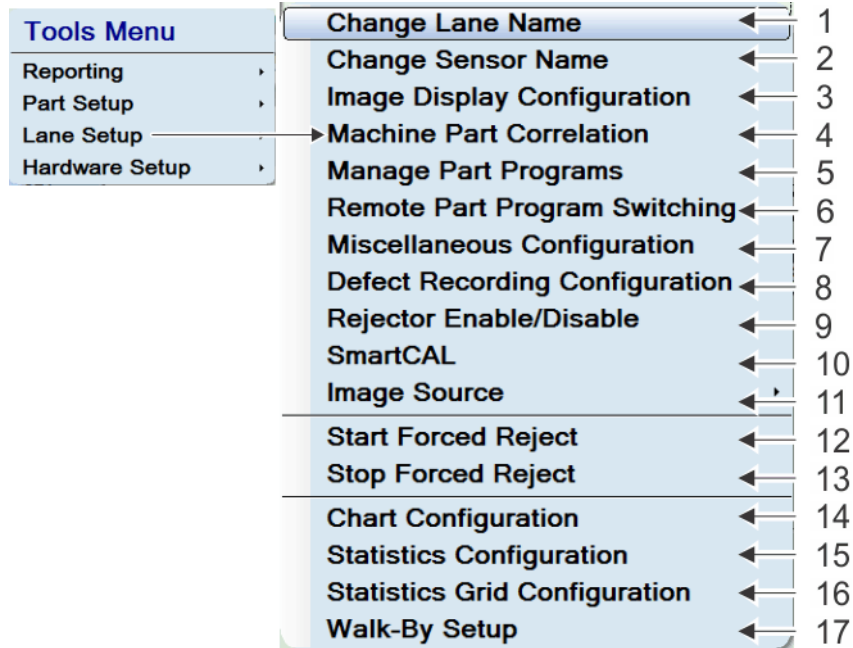

1	Change Lane Name - Change the name of the current lane.
2	Change Sensor Name - Change the name of the selected sensor.
3	<b>Image Display Configuration</b> (on page 96) - Set the frequency, rotation, and other display options for the sensor images.
4	<b>Machine Part Correlation</b> (on page 96) - Configure up to four different machine parts for correlation. [This option only appears when Correlation is configured] (This is usually done by the Pressco installer)
5	<b>Manage Part Programs</b> (on page 98) - Create, delete, or edit part programs.
6	<b>Remote Part Program Switching</b> (on page 101) - Select one of two part programs remotely.
7	<b>Miscellaneous Configuration</b> (on page 103) - Change settings for Missed Results, Inspection Warnings, and Defect Database (not currently available).
8	Defect Recording Configuration - [only shown if this option is enabled] Enable defect recording
9	<b>Rejector Enable/ Disable</b> (on page 103) - Enable or disable the rejector for lane or sensors.
10	SmartCAL - SmartCAL is a tool that allows you to load a set of images, run them with the current part program, and make sure the part program is passing or rejecting parts as you expect.
11	<b>Image Source</b> (on page 145) - Select images to display on the lane.
12 and 13	Start <b>Forced Reject</b> (on page 105) - Force parts to be rejected based on correlation to a specific machine part. Stop Forced Reject - Stop the Forced Reject process.
14	Chart Configuration – Set the number of columns in the Trend Chart and the currency type to be used in the "Cost per Part" trend chart.
15	<b>Statistics Configuration</b> (on page 69) - Change the display settings for the charts displayed by the Statistics buttons.

16	<b>Statistics Grid Configuration</b> (on page 107) - Change the amount of information for the charts displayed by the Statistics buttons.
17	<b>Walk By Setup</b> (on page 60) - Set up the group names, inspections assigned to each group, and the criteria determining when the areas of the graphic turn green, yellow, or red.

## Image Display Configuration

Adjust the display settings for images.

### ➤ To get to this screen:

From the Lane or Sensor Overview screen, click the Tools button  to see the Tools menu, then select Lane Setup, then select Image Display Configuration.

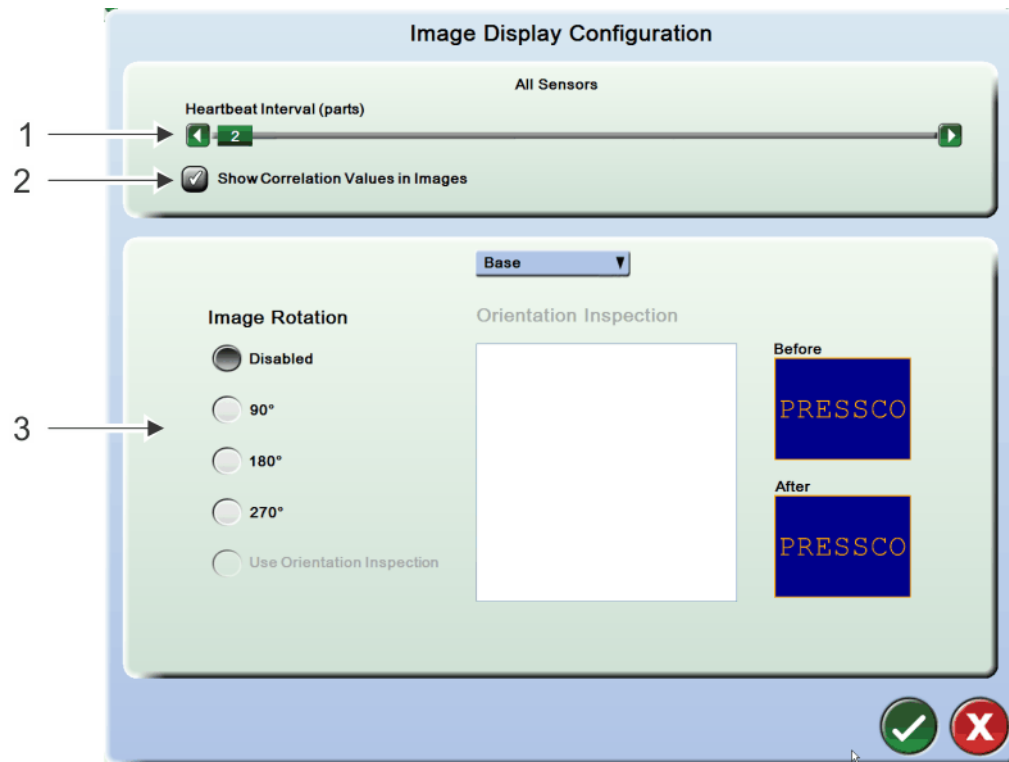

1	Set the frequency to update the image in the sensor view window.
2	If correlation is used, check this box to display correlation information in the Big Live Image view.
3	Rotate the defect images, sensor display images (heartbeat), and the Big Live Images by selecting rotation in degrees with respect to camera position, or rotation with respect to the orientation (if an orientation is being used).

## Machine Part Correlation

Configure up to four different machine parts for correlation. Each machine part can be named and assigned the correct number of stations. The offset bar is used for calibrating the displayed part with the actual machine part.

❖ *Note: This screen is usually set up by the Pressco installer.*

➤ **To get to this screen:**

From the Lane or Sensor overview screen, click the Tools button  to see the Tools menu, then select Lane Setup, then select Machine Part Correlation.

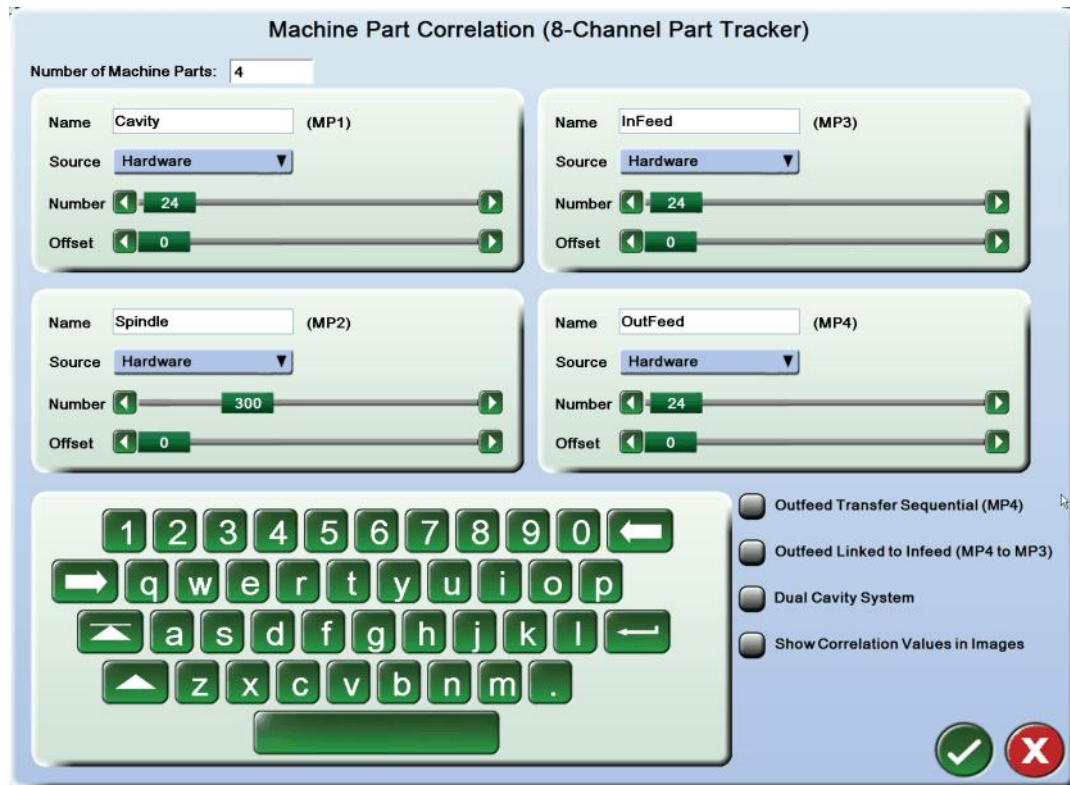

**Number Of Machine Parts**

Select the number of correlation sensors in your system (1-4).

- ❖ *Note: If you only see two Machine Parts available, you probably have a two channel Part Tracker board. This is the default configuration.*
- ❖ *If your system has an eight channel part tracker board, you must run the Discovery software and configure the lane for an eight channel part tracker board. Use the Edit Existing Lane function. This will provide the capacity for four Machine Parts to be configured.*

**Name**

Rename each machine part to something more recognizable to you (examples: Cavity, Spindle, or Liner Gun #1). This name will be displayed on the Intellispec screens and throughout correlation reports.

**Source**

Select between Hardware and Part Program to provide correlation. Some applications have inspections from which you can derive correlation information.

**Number**

Set the number of components in each machine part (example, number of pockets in a starwheel).

**Offset**

This allows you to change the mapping between what the inspection system considers part #1 (or pocket #1) and the actual parts. For example, if you try to reject a part from cavity #1, and the system rejects the part from cavity #2, then you would set offset at 1. This information is required to be correct for the inspection system to track components properly.

### Outfeed Transfer Sequential

(only available when four sensors are used, and only applicable to blow molder installations) Specify whether the infeed and outfeed transfer arms are numbered Independently or Sequentially. For example, say your machine has 10 infeed transfer arms and 10 outfeed transfer arms. If they are numbered Independently, the infeed transfer arms would be numbered 1 - 10, and the outfeed transfer arms would be numbered 1 - 10 as well. If they are numbered Sequentially, the infeed transfer arms would be numbered 1 - 10, and the outfeed transfer arms would be numbered 11 - 20.

### Outfeed Linked to Infeed (MP4 to MP3)

(applicable to blow molder installations) Enable this to derive the outfeed correlation count (MP4) from the infeed correlation count (MP3). This is typical of most blow molders. For example, in an SBO20 machine, the infeed count will be from 1 - 10. The outfeed count will be from 11 - 20. Infeed count 1 will correspond to outfeed 11, and so forth.

- ❖ Note: When this feature is enabled, the number of components is forced to be equal (number of components in MP3 = number of components in MP4 ).
- ❖ Note: There is no index sensor for MP4 in the hardware configuration.

### Dual Cavity System

(only available when four sensors are used, and only applicable to blow molder installations) Enable this if your system is a dual cavity machine.

### Show correlation values in images

Displays the correlation value in the images. These values are saved as part of the image file (if you save images).

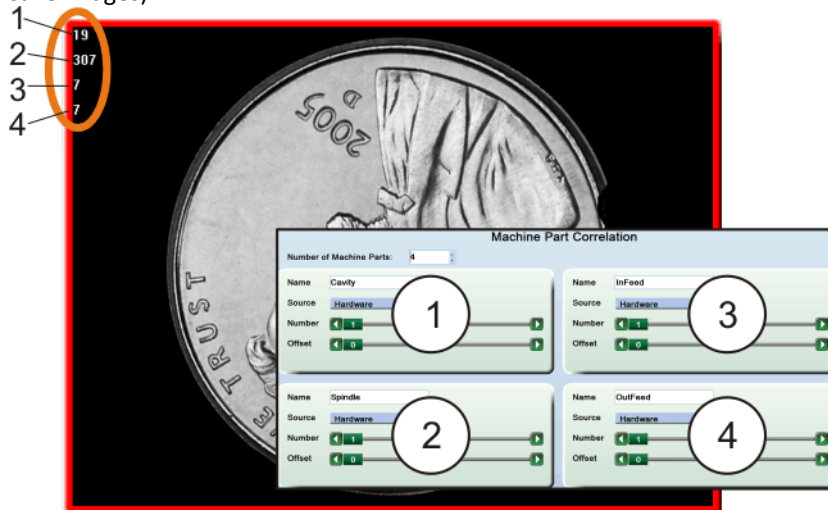

## Manage Part Programs

Create new part programs or delete, edit, rename, import or export existing part programs for all the different products inspected with the system.

### ➤ To get to this screen:

- From the Lane or Sensor Overview screen, click the Tools button  to see the Tools menu, then select Lane Setup, then select Manage Part Programs. Or:
- Right-click the Part Program drop-down menu.



For information on using this screen see:

- **How to Create, Copy, or Import a Part Program** (on page 168)
- **Export a part program** (on page 100)
- **Load a Part Program** (on page 100)

## Delete a part program

You can delete a part program to prevent other users from running it.

### ➤ To delete a part program:

1. Go to a Lane Overview or Sensor Overview screen [from Home: Lane button > Sensor button].
2. Load a known good part program, one that you will not delete. You cannot delete the currently running part program.
3. Right-click over the part program drop-down menu. The Manage Part Programs menu is displayed.
4. Highlight the program name in the Manage Part Programs menu, then click the **Delete** button.
5. A warning box will ask you if you are sure you want to delete the program. Click the OK button  to delete the program. The program is deleted from memory.

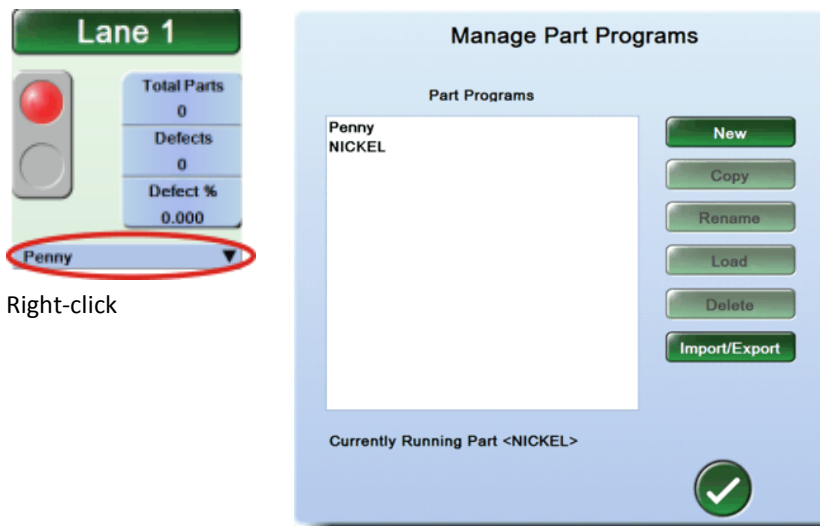

### Load a part program

You can switch part programs by loading a different part program from disk.

#### ➤ To load a part program:

1. Go to a Lane Overview or Sensor Overview screen [from Home: Lane button > Sensor button].
2. Right-click over the part program drop-down menu. The Manage Part Programs menu is displayed.
3. Highlight the program name in the Manage Part Programs menu, then click the **Load** button. The program name will appear in the Part Program drop-down menu on the Lane Overview or Sensor Overview screen.
4. Click the OK button  to exit the Manage Part Programs menu. The new part program is loaded into the Intellispec memory.

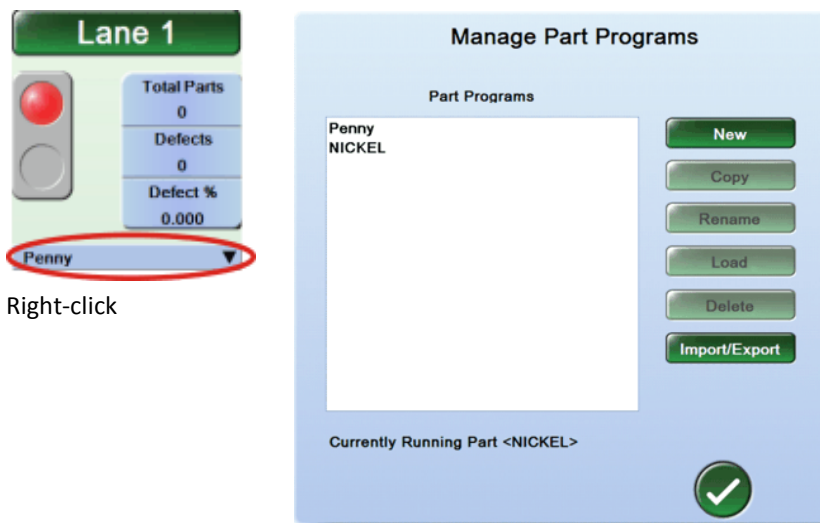

## Export a part program

You can export a part program to use it on another sensor, lane, or Intellispec.

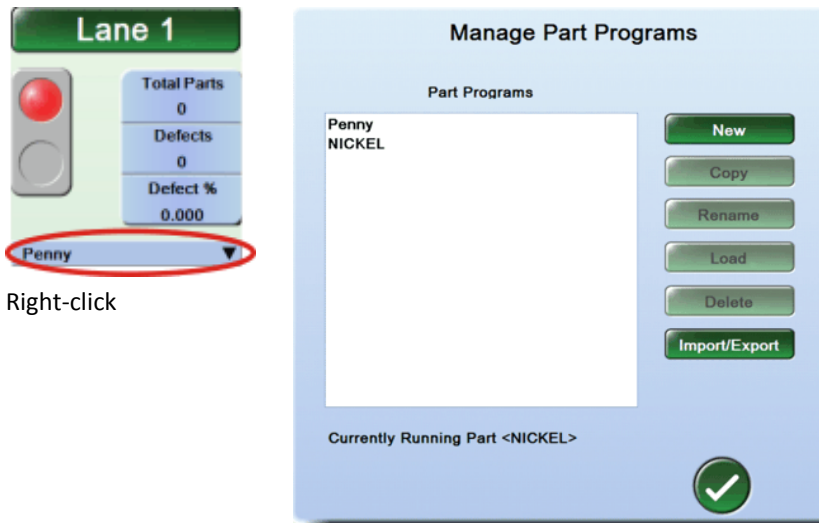

### ➤ To export a part program:

1. Go to a Lane Overview or Sensor Overview screen [from Home: Lane button > Sensor button].
2. Right-click over the part program drop-down menu. The Manage Part Programs menu is displayed.
3. Click the **Import/Export** button. The Import or Export Part Programs menu is displayed.



4. Click the disk icon  to browse to the folder or USB destination to export the part program.
5. Highlight the part program that you want to export in the Current Part Programs column.
6. Click the right arrow button  to export the part program.
7. Click the OK button  to exit the Import or Export Part Programs menu. The part program is exported.
8. Click the OK button  to exit the Manage Part Programs menu.

## Remote Part Program Switching

❖ *Note: this feature is available in versions 5.0.493, 5.2.026, 5.3.005 and higher versions of software.*

The Remote Part Program Switching function is used to select one of two part programs remotely through a PLC.

### ➤ *To use Remote Part Program Switching:*

- Your system must have an Extended I/O board connected to the tracker board for the lane on which you are using the function, and
- You must have user access permission to Manage Part Programs. See Managing Permissions.
- You must have at least two part programs already configured

### ➤ *To use the Remote Part Program Switching menu:*

1. From Lane Overview or Sensor Overview mode, select the Tools  button > Lane Setup > Remote Part Program Switching. This item will be disabled if there is no Extended I/O board or if the system is online.

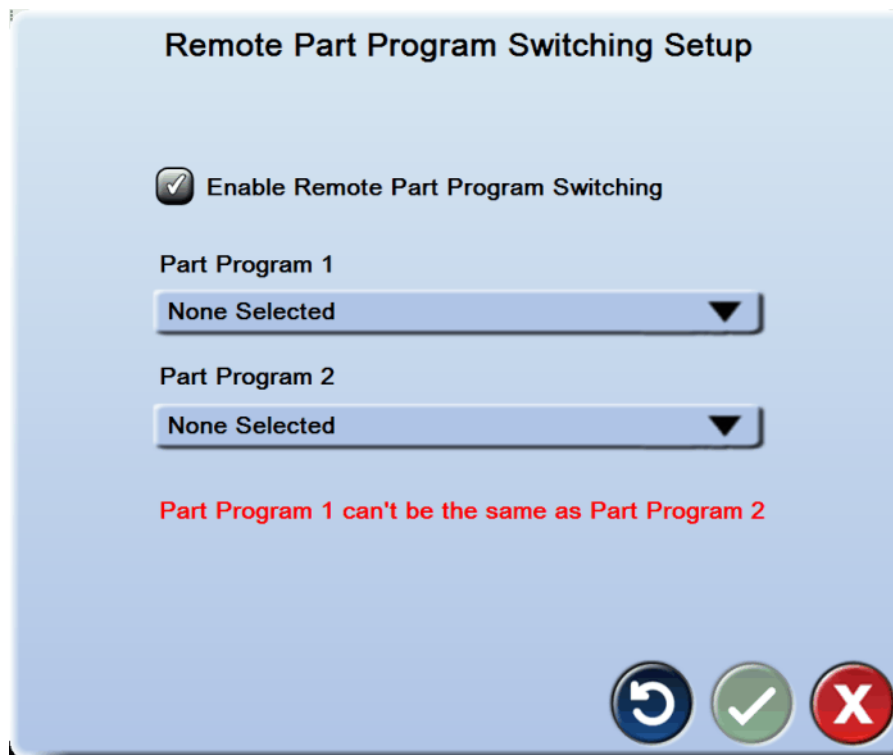

2. Enable the function by checking the Enable Remote Part Program Switching box.
3. Select Part Program 1 from the drop-down list available.
4. Select Part Program 2 (different from Part Program 1) from the drop-down list available.
5. Select the OK button to complete the selection and exit. The Remote Part Program Switching function is enabled.

Connect to the Extended I/O board. Reference these topics:

- **Extended I/O board** (on page 337)
- **Extended I/O signals** (on page 338)
- **Extended I/O circuits** (on page 342) (for information about how to connect your equipment to the board)

### ➤ *On the Extended I/O board, follow this sequence to select a part program:*

1. Set Input Port Strobe (J1-11) low.
2. Set Generic Input 0 (J1-3) and Generic Input 1 (J1-4) low.
3. Pulse Input Port Strobe high and then low. (This clears the input state.)

4. Set either Generic Input 0 or Generic Input 1 high.
5. Pulse Input Port Strobe high and then low. (This selects part program 1 if Generic Input 0 is high or part program 2 if Generic Input 1 is high.)

Timing considerations are as follows:

- Generic Input change to Pulse Input Port Strobe transition 10 microseconds minimum.
- Input Port Strobe high time 10 microseconds minimum.
- When the above sequence is performed, the system will go offline which brings System State (J4-16) low. The part program is changed and then the system is put back on line which sets the System State output high.
- The part selection sequence can be commanded when the system is offline. In this case, the part program is changed but the system does not go online automatically.

## Miscellaneous Configuration

Enable or disable additional lane options.

### ➤ To get to this screen:

From the Lane or Sensor Overview screen, click the Tools button  to see the Tools menu > Lane Setup > Miscellaneous Configuration.

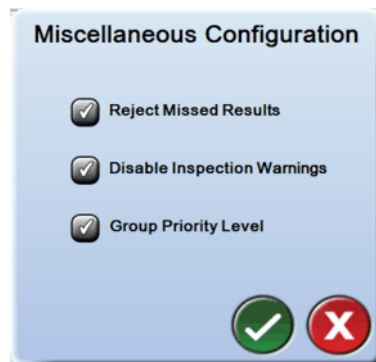

### Reject Missed Results

A missed result occurs if the system misses the inspection results of a part. This can happen if the inspection time is too long or if the system is too busy to process all the data before the part reaches the reject station.

Check this box if you want the system to reject parts from any missed results in the current Lane.

### Disable Inspection Warnings

Inspections can have reject and/or warning limits. A warning allows you to perform maintenance or adjustments before the system starts rejecting parts.

The warning limits are represented by the yellow adjustable slider bar on the Retro-Spec graphs. If you do not wish to use warning limits, check the Disable Inspection Warnings box.

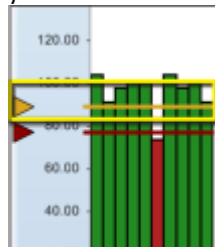

### Group Priority Level

This feature allows you to assign a priority to each group within the Walk By graphic. You can designate which defects are more important and prioritize the reporting structure accordingly. See Group Priority Level

## Rejector Enable/ Disable

Enable or disable the rejector at the Sensor level or at the Lane level.

- If one or more Sensors are checked, the reject device for all inspections performed by those Sensors is disabled.

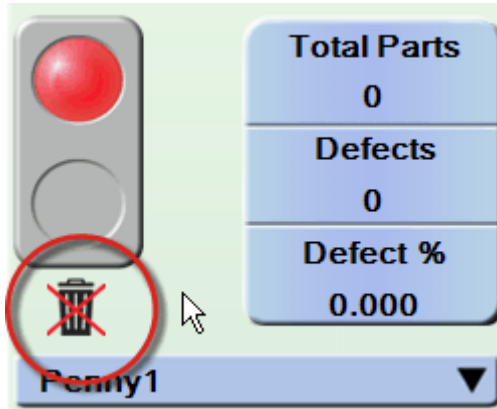

- If all Sensors are checked, the reject device is disabled at the Lane level. An icon is displayed in the Lane window to indicate that the rejector is disabled.

❖ *Note: the trash can symbol is only displayed if ALL sensors within the lane are disabled.*

### ➤ *To enable or disable the rejector for one sensor only:*

1. Go to Sensor Overview mode.
2. Right-click over the desired sensor button to see the Sensor menu.
3. Click "Reject Enabled" to toggle it to "Reject Disabled" or vice versa. If Reject Enabled is displayed, the rejector is enabled.

If you put the system online when the Sensor rejector is disabled, you will see a message stating "Sensor Rejector Disabled - Do you want to go online?"

### ➤ *To enable or disable the rejector for one or more sensors within a lane:*

1. From Lane Overview or Sensor Overview mode, click the Tools button  to go to the Tools menu.
2. From the Tools menu, click Lane Setup, then select Rejector Enable/ Disable.
3. Check or un-check the box next to the sensor(s) to enable or disable the rejector.

- Click the OK button to apply the changes and exit the menu. The new setting is applied. If the rejector for all sensors within the lane is disabled, you will see the trash can icon near the statistics for that lane.



If you put the system online when the lane rejectors are disabled, you will see a message stating "Lane Rejector Disabled - Do you want to go online?"



### ***Forced Reject***

The Forced Reject feature allows you to force any part to be rejected. The system will reject all parts associated with the checked components, regardless of the pass/fail condition of those parts. This provides a means of handling an emergency situation until repairs on a blow-molder or other machine can be made. If you know there is a serious problem with a particular component, you can use this method to ensure that no part from the defective machine component passes the inspection process.

❖ *Note: the correlation check boxes and machine parts are only displayed if your machine is using correlation.*

➤ **To get to this menu:**

From the Lane or Sensor Overview screen, click the Tools button  to see the Tools menu, then select **Lane Setup**, then select **Start Forced Reject**.



The parts of the menu are as follows:

❖ *Note: The lane must be online to force rejects.*

### **Reject One Part/ Reject N Parts/ Continuous Reject**

Reject one part, 'N' parts, or continuously reject from a specific machine part. To begin rejecting, click the **Start Forced Reject** button.

**Reject One Part** - rejects the next part that reaches the reject station, regardless of its inspection status. If you select Single or Combined Machine Parts in the above drop-down menu, the part must meet that criteria.

**Reject N Parts** - the numeric field next to this drop-down menu becomes active. Enter a number of parts you want to reject, regardless of their inspection status. If you select Single or Combined Machine Parts in the above drop-down menu, the part(s) must meet that criteria.

**Continuous Reject** - rejects all parts regardless of their inspection status, until you click the **Stop Forced Reject** button. If you select Single or Combined Machine Parts in the above drop-down menu, the part(s) must meet that criteria.

### **Skip N Parts Between Parts**

Uses the criteria set up with the Reject One Part/ Reject N Parts/ Continuous Reject menu, adding a number of parts that you specify between rejected parts.

### **Cavity /spindle/ infeed/ outfeed**

The names displayed in this section will correspond to the names of your machine part components. These are only shown if you select Single or Combined Machine Parts in the first drop-down menu. Specify the number of the machine part correlated to the part you want rejected.

### **Rejector**

(Not shown in the above screen) Specify which rejector to force rejection of part. If you only have one rejector, then this button is not applicable.

### **Numeric Keypad**

This is used to type values for numbers or series of rejected parts or correlation to machine parts.

### Start Forced Reject/ Stop Forced Reject

When you click **Start Forced Reject**, the criteria specified in the menu is applied and the parts are rejected. Click the **Stop Forced Reject** button to stop the reject process. Note that if you only reject one part, or specify a number of parts, the button toggles back to **Start Forced Reject** automatically.

### Status Box

Displays information about the rejection process.

## Statistics Grid Configuration

Choose how the statistics grids are displayed.

### ➤ To get to this screen:

From the Lane or Sensor Overview screen, click the Tools button  to see the Tools menu, then select Lane Setup, then select Statistics Grid Configuration.

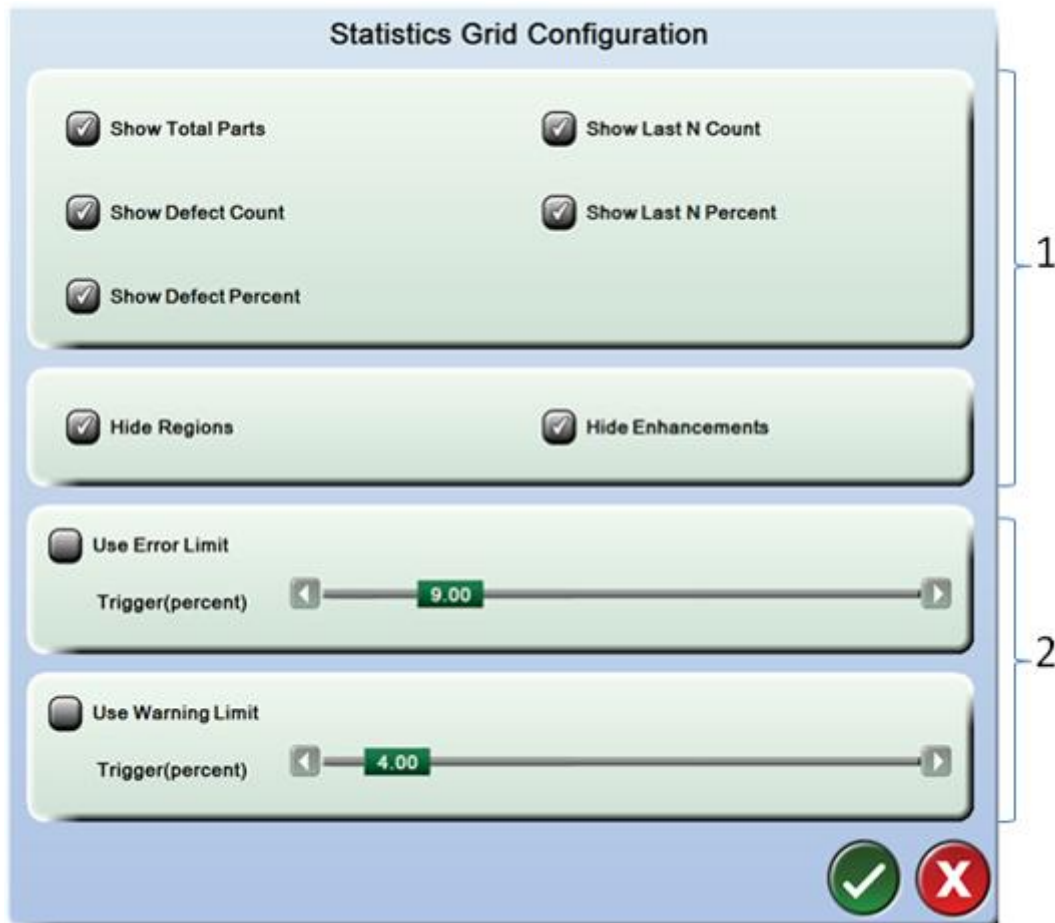

1	Checking these boxes determines what information is shown on the Statistics Grid screen.
2	These two sliders allow you to enable/disable and determine the setting for warning and error limits applied to the Statistics Grid screen.

## Hardware Setup

Some menu items are only available to advanced level users.

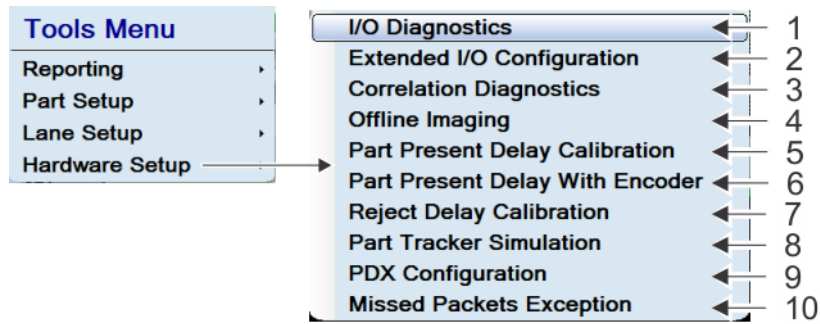

1	<b><i>I/O Diagnostics</i></b> (on page 108) - Verify the presence of input and output signals.
2	<b><i>Extended I/O Configuration</i></b> (on page 344) - Configure the optional Extended I/O board.
3	<b><i>Correlation Diagnostics</i></b> (on page 109) - Verify correlation signals.
4	<b><i>Offline Imaging</i></b> (on page 137) - Choose how the Intellispec acquires images when the lane is offline.
5	<b><i>Part Present Delay Calibration</i></b> (on page 110) - Calibrate the distance (in encoder pulses) from the part detect sensor to the camera centerline.
6	<b><i>Part Present Delay with Encoder</i></b> (on page 112) - Coarsely calibrate the part present delay by using encoder counts.
7	<b><i>Reject Delay Calibration</i></b> (on page 113) - Calibrate the distance (in encoder pulses) from the part detect sensor to the rejector.
8	Use <b><i>part tracker simulation</i></b> (on page 117) for troubleshooting or if a part detect sensor is bad. A simulated part rate would allow inspection to continue.
9	<b><i>PDX Configuration</i></b> (on page 118) - Set up the part detect generator. Only used in some applications.
10	<b><i>Missed Packets Exception</i></b> (on page 120) - Set the number of missed packets to trigger the part tracker to send a Lost Part Tracking message to the Intellispec.

### ***I/O Diagnostics***

#### ➤ ***To get to this screen:***

From the Lane or Sensor Overview screen, click the Tools button  to see the Tools menu > Hardware Setup > I/O Diagnostics.

This screen can be used to verify the presence of input and output signals. Part rate and encoder rate are also displayed.

- Green lights are input signals (signals that originate outside the Intellispec and are communicated to the system). When an input is received the light is on.
- Red lights are output signals (signals that originate inside the Intellispec and are transmitted out of the system). When an output is generated the light is on. You can test an output signal by clicking on the appropriate light.

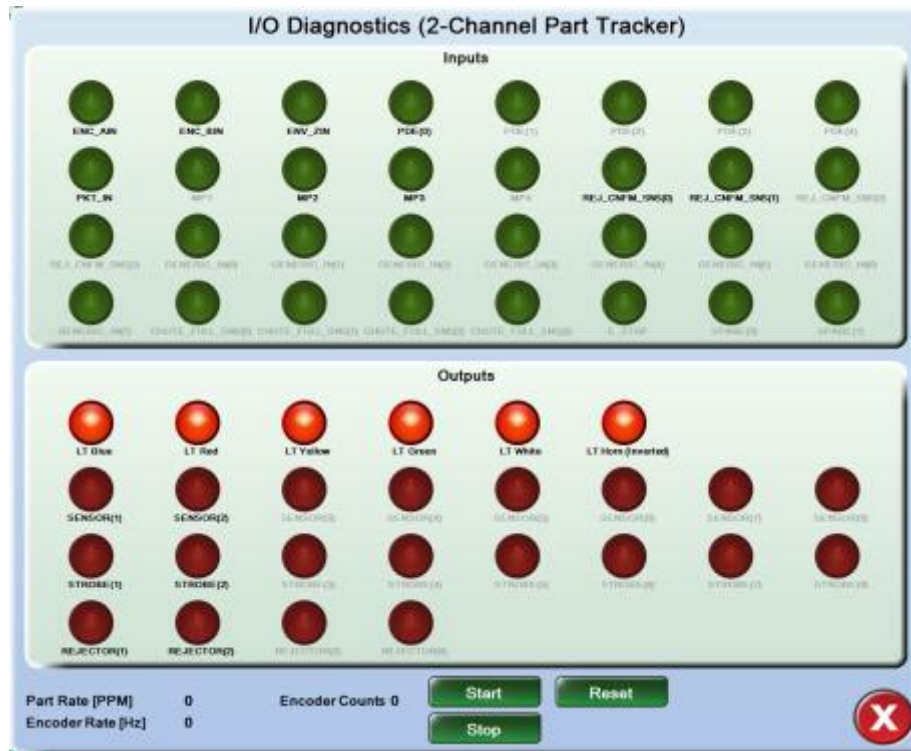

The outputs correspond to the hard-wired input and output signals throughout the Intellispec system.

## Encoder counts

At the bottom of the screen, you can use the diagnostics and buttons to count encoder pulses. This is used as an approximate number of encoder counts to assist in setting up part tracking sensors along with other machine part hardware.

❖ *Note: due to start and stop time of machine components, the encoder count will not be exact. This tool is used for approximation of encoder counts.*

### Encoder Counts

The encoder count from the part tracker board. The board continually counts, and restarts at zero when you press the **Reset** button.

### Start button

Begin displaying encoder pulses.

### Stop button

Stop updating the encoder pulse display. The part tracker will remain counting, but the display will stop updating.

### Reset button

Reset the part tracker board encoder count.

## Correlation Diagnostics

This is a troubleshooting tool to verify that correlation sensor information is being received by the Intellispec.

### ➤ To get to this screen:

From the Lane or Sensor Overview screen, click the Tools button  to see the Tools menu, then select Hardware Setup, then select Correlation Diagnostics.

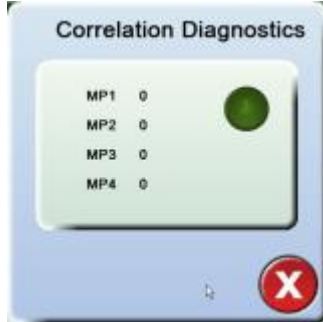

For systems that have correlation sensors, this screen is used to verify that the correlation sensor information is being received by the system. It is a troubleshooting tool.

As the production unit is operating, if the correlation sensor is transmitting pulses, it will come up in the appropriate window. For example, if you have a cavity sensor attached to machine part one (MP1) and are running an 8-cavity blow molder, you will see MP1 increment from 1-8 repeatedly.

Make sure that each machine part (MP) increments according to the number of components in your system.

MP = Machine Part. MP1 through MP4 correspond to the correlation sensors that you have configured in the **Machine Part Correlation** (on page 96) screen.

## Part Present Delay Calibration

Part Present Delay is the distance (in encoder pulses) from the part detect sensor to the camera centerline. Two independent signals are generated: 1) light strobe and 2) camera snap.

❖ *Note: if your system is using a PDX, set up **PDX Configuration** (on page 118) before Part Present Delay.*

The Part Present Delay ensures that your part is in the center of the image when the camera snaps its picture. Depending on the orientation of your camera, your part could be moving from left to right, right to left, top to bottom or bottom to top as it travels through the camera's field of view. You need to be aware of the part flow direction in order to set up the Part Present Delay Calibration.

For an illustration of Part Present Delay within the inspection process, refer to the **Sequence of Events During Inspection** (on page 168).

Even if you are unsure what the Part Present Delay value should be, you can view the strobing of the lights to gauge whether the delay has been set too long or too short. When the Part Present Delay value has been set too short, the lights will strobe before the part reaches the camera; likewise when the delay is set too long, the lights will strobe after the part has passed the camera. When the part is close enough to be in the actual image that the camera acquires, you can use the image itself to center the part. A Part Present Delay calibration needs to be done for each camera in the system.

## Calibration

When you calibrate the Part Present Delay, it is ideal to only use one part at a time. Otherwise, it will not be easy to determine if the part detected is actually the same part in the image or the part rejected (for Reject Delay) since all the parts look alike. If it is not possible to use only one part, an alternative is to use a different color part. You will most likely use a few parts to test the calibration, or run the same part through several times.

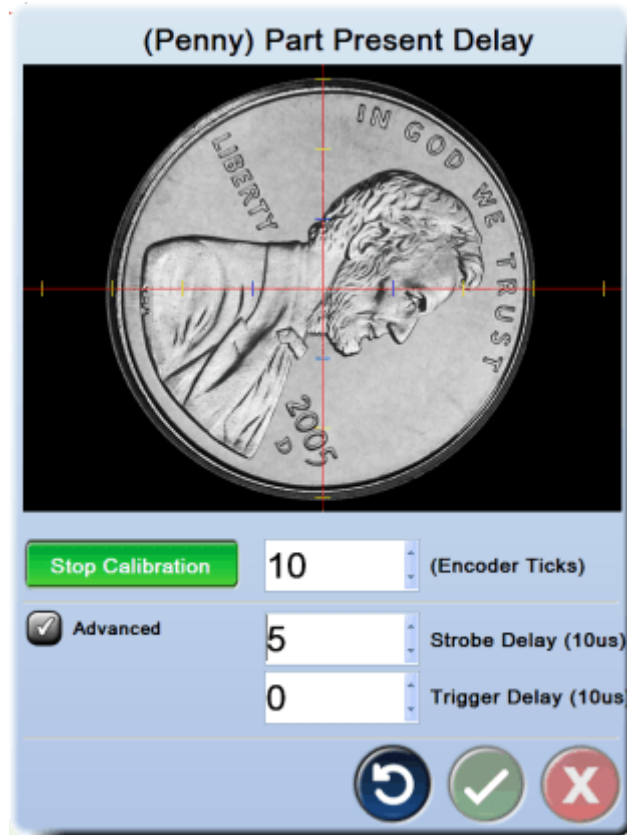

### ➤ To calibrate the Part Present Delay:

❖ *Note: you must be logged in with proper user access to calibrate the Part Present Delay.*

1. From the Sensor Overview mode, right-click on a sensor button to view the **sensor menu** (on page 135).
2. Select Part Tracking, then select Part Present Delay Calibration.
3. Click the **Start Calibration** button.
4. Place a part onto the conveyor or into the part stream. The part will trigger the part detect sensor, then the system will count the number of encoder pulses and take a picture.
5. Manually adjust the part present delay (encoder ticks) value until the image is centered every time a part is run through the system.
6. When completed, click the **Stop Calibration** button. The Part Present Delay calibration value is saved and stored in a Lane configuration file.

## Advanced settings

❖ *Note: Advanced settings are normally set at the Pressco factory. You should not need to adjust them. Normal settings are listed below.*

Set a Base/Neck configuration as follows:

Camera	Strobe Delay	Trigger Delay	Part Present Delay
Base	5	0	same as Neck
Neck	5	30	same as Base

Also check **Advanced adjust lighting - set delay** (on page 143) to make sure that the Neck lighting delays are set correctly.

## Part Present Delay with Encoder

This tool provides a rough calibration of the part present delay by using encoder counts. You can fine tune the calibration using the **Part Present Delay Calibration** (on page 110) tool. Up to eight buttons (sensors) may be displayed on this screen, depending on your system configuration. Each part present delay is set separately, unless the sensors use the same sensor trigger (as in Base/Neck modules).

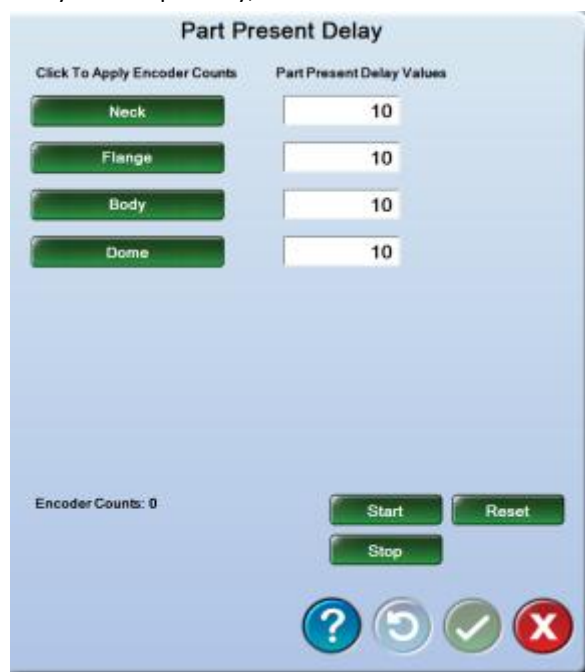

### ➤ To set the Part Present Delay with Encoder:

1. Run the conveyor or machine slowly or by hand, and place a part before the part present sensor.
2. When the part reaches the part present sensor, and you see the Part Present LED flash on the inspection module or cluster box I/O box, select the **Reset** button to set the encoder count to zero.
3. Press the **Start** button to begin counting encoder pulses
4. Run the conveyor slowly so that the part passes in front of or underneath the sensor.
5. When the part reaches the sensor, press the **Stop** button to stop counting encoder pulses.
6. Press a sensor button [example: Neck or Dome] to apply the encoder counter to the sensor's Part Present Delay value.
7. Repeat this process for the remaining sensors.
8. Select the OK button  to save changes and exit.

## ENCODER COUNTS

### Encoder Counts

The encoder count from the part tracker board. The board continually counts, and restarts at zero when you press the **Reset** button.

### Start button

Begin displaying encoder pulses.

### Stop button

Stop updating the encoder pulse display. The part tracker will remain counting, but the display will stop updating.

### Reset button

Reset the part tracker board encoder count.

## Reject Delay Calibration

Reject Delay is the distance (in encoder pulses) from the part detect sensor to the rejector. This signal ensures that the correct part is rejected.

During Reject Delay calibration, the reject device will activate for each part that flows through the system. Ensure that the rejector is activated properly and that each part is rejected properly. After calibration, ensure that adjacent parts are not being rejected (example, from too long a reject dwell time), nor being knocked off by the rejected part.

For an illustration of the Reject Time Delay within the inspection process, refer to the **Sequence of Events During Inspection** (on page 168).



### ➤ To calibrate the Reject Delay:

❖ *Note: you must be logged in with proper user access to calibrate the Reject Delay.*

1. From the Sensor Overview mode, right-click on a sensor button to view the **sensor menu** (on page 135).
2. Select Part Tracking, then select Reject Delay Calibration.
3. Click the **Start Calibration** button.
4. Place a part on the running conveyor or into the part stream. After the number of encoder pulses shown in the Reject Delay box, the rejector will be activated.
5. Make sure the correct part was rejected.

6. Continue to insert parts into the part stream.
7. Manually adjust the reject delay (encoder ticks) until the correct part is rejected every time.
8. Adjust the Reject Dwell so that it is long enough to completely reject the part, and short enough that only one part is rejected for each reject pulse.
9. When completed, click the **Stop Calibration** button. The Reject values are saved and stored in a Lane configuration file.

### Reject Dwell

The duration of the reject signal. Dwell can be set by encoder ticks or by milliseconds. Select the correct button for your application. This signal must be long enough to ensure the part is efficiently rejected, and short enough to ensure that only one part is rejected for each reject pulse.

### Adaptive Reject

**Adaptive Reject (optional)** (on page 114)

### **Adaptive Reject (optional)**

This topic applies if your system has Part Tracker firmware version **F185 or higher**. If you have this firmware, the Reject Delay Calibration will show "**Max Encoder Frequency**" in the lower menu. If your menu shows "Diff. from Calibration [%]," then go to **Adaptive Reject (optional) - older version** (see "**Adaptive Reject (optional)**" on page 116).

This feature is used to compensate for the reject device's turn-on time delay with varying speeds of machine operation. An example where this is used is on a Belvac machine. The turn-on time of the reject device might be over one-half of a can width at high machine speeds. The Adaptive Reject will delay the activation of the reject device as a function of encoder speed. As the belt (or production line) slows down, more delay is added.

Adaptive Reject allows for different speeds without having to recalibrate between part types.

#### ➤ **For best results when using Adaptive Reject:**

- Calibrate the **Reject Delay** (see "**Reject Delay Calibration**" on page 113) and Reject Dwell at the fastest possible conveyor or production line speed **prior to enabling the Adaptive Reject function**
- Calibrate the Reject Delay when the conveyor or production line is running at a constant speed -- not during a startup or stopping

❖ *Note: Adaptive Reject will not function properly if the reject device delay is greater than the spacing between parts.*

#### ➤ **To set Adaptive Reject:**

1. Go to the **I/O Diagnostics** (on page 108) screen and record the encoder rate while the line is running at max speed.
2. Go to the Reject Delay Calibration menu: Right-click over a sensor button > Part Tracking > Reject Delay Calibration.
3. Click the check box next to Use Adaptive Reject in the **Reject Delay Calibration** (on page 113) menu to enable the feature.
4. Set the Max Encoder Frequency to the value you recorded in step 1.
5. Set the reject device Turn On Time (usually about 10 ms for air rejectors and about 15 ms for the pusher rejector).

6. Click the OK button  to save changes and exit the Reject Delay Calibration menu.



Settings for Adaptive Reject:

**Turn On Time**

Latency of the rejector mechanism in milliseconds.

**Max Encoder Frequency**

Maximum encoder frequency of the starwheel or conveyor.

❖ *Notes:*

- Reject Delay should be calibrated with the system running at the maximum encoder frequency.
- A positional error will occur if the encoder frequency exceeds the maximum encoder frequency.

The table below shows the computed value of the delay based on encoder speed and how the resultant delay (in encoder ticks) is the same regardless of speed.

Max Encoder Frequency (Hz)	Encoder Frequency (Hz.)	Computed Delay (encoder ticks) (A)	Reject device turn-on delay (encoder ticks) (B)	Total movement (encoder ticks) (A + B)
10000	500	95	5	100
10000	1000	90	10	100
10000	2000	80	20	100
10000	3000	70	30	100
10000	4000	60	40	100
10000	5000	50	50	100
10000	6000	40	60	100
10000	7000	30	70	100
10000	8000	20	80	100
10000	9000	10	90	100
10000	10000	0	100	100

- Computed Delay (Encoder Ticks) (A) = [Max Enc Freq (Hz) – Enc Freq (Hz)] \* Reject Turn-on Delay (msec) / 1000
- Rejecter Latency (Encoder Ticks) (B) = Enc Freq (Hz) \* Reject Turn-on Delay (msec) / 1000
- Total Movement = A+B

### **Adaptive Reject (optional)**

This topic applies if your system has a part tracker **firmware version below F185**. You can tell by the Reject Delay Calibration menu. If the lower part of the menu has "Diff. from Calibration [%]" then follow the instructions in this topic. If the menu shows "Max Encoder Frequency" then go to **Adaptive Reject** (see "**Adaptive Reject (optional)**" on page 114).

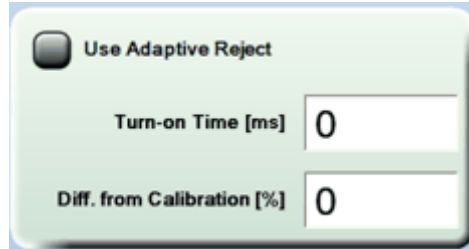

This feature is used to compensate for the reject device's turn-on time delay with varying speeds of machine operation. An example where this is used is on a Belvac machine. The turn-on time of the reject device might be over one-half of a can width at high machine speeds. The Adaptive Reject will delay the activation of the reject device as a function of encoder speed. As the belt (or production line) slows down, more delay is added.

If you do not know the fastest conveyor or production speed when you are setting Reject Delay, you could calibrate the Reject Delay again when you run a different part at a different production speed. Adaptive Reject allows for different speeds without having to recalibrate between part types.

#### ➤ **For best results when using Adaptive Reject:**

- Calibrate the **Reject Delay** (see "**Reject Delay Calibration**" on page 113) and Reject Dwell at the fastest possible conveyor or production line speed **prior to enabling the Adaptive Reject function**
- Calibrate the Reject Delay when the conveyor or production line is running at a constant speed -- not during a startup or stopping

❖ *Note: Adaptive Reject will not function properly if the reject device delay is greater than the spacing between parts.*

#### ➤ **Before calibrating Adaptive Reject:**

1. If you have not done so already, calibrate Reject Delay and Dwell. See **Reject Delay Calibration** (on page 113) for more information.
2. Write down or make note of the Reject Dwell value after Reject Delay calibration. You will need to temporarily change this during Adaptive Reject calibration.

#### ➤ **To calibrate Adaptive Reject:**

1. Click the check box next to Use Adaptive Reject in the **Reject Delay Calibration** (on page 113) menu to enable the feature.
2. Set Reject Dwell to zero during the Adaptive Reject calibration process.
3. Run the conveyor or production line at the fastest speed that you will use, and click the **Start Calibration** button.
4. Let the conveyor or production line run for about 20 seconds. The part tracker will record the maximum encoder frequency. It will use this number to determine the amount of delay to be applied to the rejector at all other encoder frequencies.
5. Click the **Stop Calibration** button.
6. Set the Reject Dwell back to the value originally calibrated during Reject Delay calibration (the number you noted *before calibrating Adaptive Reject*).
7. Enter the Turn On time of the reject device installed in your system.

8. Enter a value for **Max Encoder Frequency** or **Diff. from Calibration %**, if applicable. See more information below.
9. Click the OK button  to save changes and exit the Reject Delay Calibration menu.



Settings for Adaptive Reject:

#### Turn On Time

Latency of the rejector mechanism in milliseconds.

#### Diff(erence) from Calibration (%)

This number is used if the maximum speed of the conveyor or production line is greater than the speed at which the Reject Delay was calibrated. For example, if you calibrated the conveyor for one part where the conveyor runs at a slower speed, and know that you will run the conveyor 20% faster for another part, then enter 20 for Diff. from Calibration.

The ideal setting is zero. However, a value of approximately 10 is acceptable, to allow for speed fluctuations due to power surges.

❖ *Note: this value only applies to potential speeds greater than calibration speeds, not slower speeds.*

## Part Tracker Simulation

Use part tracker simulation for troubleshooting or if a part detect sensor is bad. A simulated part rate would allow inspection to continue.

➤ **To get to this screen:**

From the Lane or Sensor Overview screen, click the Tools button  to see the Tools menu, then select Hardware Setup, then select Part Tracker Simulation.

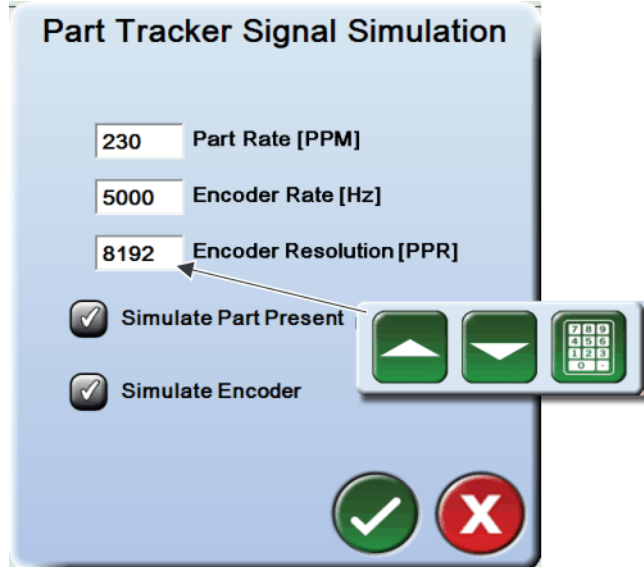

To enable the simulated part tracker, click the check box and then enter the desired part rate in the window.

**Part Rate** - Enter a simulated part rate in parts per minute (PPM).

**Encoder Rate** and **Resolution** - Enter the simulated encoder properties.

❖ *Note: the system cannot run in both **PDX** (see "**PDX Configuration**" on page 118) mode and **Part Tracker Simulation** (on page 117) mode at the same time. If one mode is already running and you enable the other mode, the system displays a warning that the latest setting will override the previous mode.*

## PDX Configuration

The Part Detect Generator (PDX) is used in some applications where the Intellispec system inspects directly on a machine, rather than on a conveyor. The PDX is a circuit built into the Part Tracker board.

❖ *Note: the system cannot run in both PDX (see "PDX Configuration" on page 118) mode and Part Tracker Simulation (on page 117) mode at the same time. If one mode is already running and you enable the other mode, the system displays a warning that the latest setting will override the previous mode.*

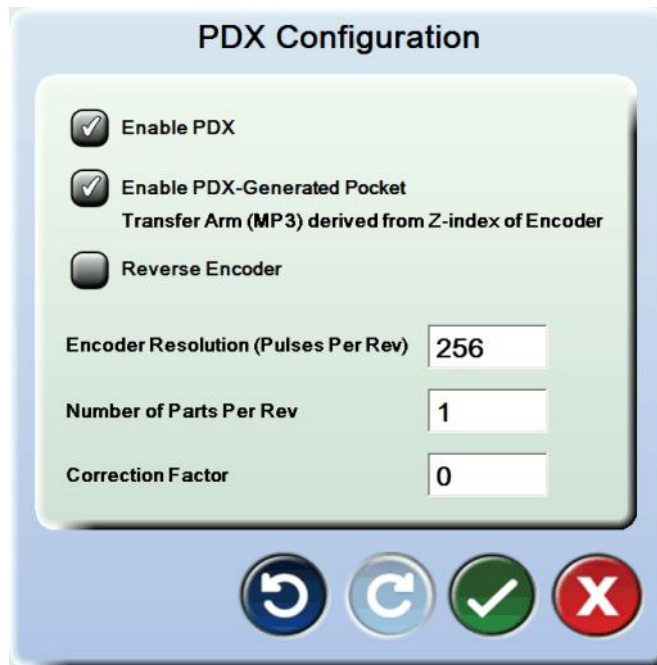

### ➤ To get to this screen:

1. From the Lane Overview or Sensor Overview screen, click the Tools button  to see the Tools menu.
2. Select Hardware Setup, then select PDX configuration. The parameters are described below:

#### Enable PDX

Enables the PDX circuit.

#### Enable PDX-Generated Pocket

- If your system is using a physical pocket disk with an index pin, leave this box un-checked.
- If your system is not using a pocket disk, and you need the Z-index signal of the encoder, check this box. This eliminates the need for a pocket disk. The index signal is handled on the Part Tracker board.

#### Reverse Encoder

Reverses the direction of the encoder pulses. Instead of the normal A, B sequence of pulses, the pulses switch to B, A.

#### Encoder Resolution (Pulses Per Rev)

Enter the resolution of the encoder installed on your machine.

#### Number of Parts Per Revolution

Enter the number of machine parts (example, number of Transfer Arms) to which the encoder is attached.

### ➤ To configure the PDX:

1. Click the Enable PDX check box.
2. Enter the encoder resolution used on your system (example, 8192 pulses per revolution).

3. If your system is NOT using a pocket disk to generate the index signal, check the Enable PDX-Generated Pocket box.
4. Click the OK button  to accept changes and exit.

## Missed Packets Exception

For each part and for each camera, two packets of information are communicated:

- The part tracker sends the host PC a signal stating the camera has been triggered (correlation signal)
- The host PC then sends a pass/fail signal back to the tracker (results signal) when the inspections are done

A missed packet exception occurs when the part tracker has sent out X number of correlation signals without receiving any results signals back from the PC. The default is set at 6.

When this number has been met a **Lost Part Tracking** input is received on the **Sensor Missed Statistics** (on page 91) screen.

### ➤ To get to this screen:

From the Lane or Sensor Overview screen, click the Tools button  to see the Tools menu, then select Hardware Setup, then select Missed Packets Exception.



Set the number of missed packets to trigger the part tracker to send a Lost Part Tracking message to the Intellispec.

## Reject Confirm Calibration (Optional)

Reject Confirm can detect missed rejects. Coupled with the **Missed Reject Alarm** (see "**Lane Alarms Description**" on page 79), Reject Confirm will reliably detect and notify you of any missed reject condition.

❖ *Note: Reject Confirm is an optional feature, and an additional sensor must be installed at your site.*

Reject Confirm uses a part detect sensor positioned at a calibrated and defined distance (Reject Confirm Delay) past the normal reject mechanism to determine whether the defective part was actually rejected. Reject Confirm Delay must be a value of 1024 or less.

After the rejector fires (meaning the reject delay for a part has passed), the Reject Confirm Delay starts. Once the Reject Confirm Delay has passed, the system examines the reject confirm sensor for a period of time equal to the Part Width. If the reject confirm sensor "sees" a part within that time, it means that the reject was missed. If the reject confirm sensor does not see a part, it means the part was rejected successfully.

If the reject was missed, the Missed Reject Alarm will be triggered. However, the **Missed Reject Alarm** (see "**Lane Alarms Description**" on page 79) must first be enabled and configured.

Below is a timing diagram of the Reject Confirm process.



1	<b>Reject Delay</b> (see " <b>Reject Delay Calibration</b> " on page 113)
2	<b>Reject Dwell</b> (see " <b>Reject Delay Calibration</b> " on page 113)
3	Reject Confirm Delay, set by Reject Confirm Calibration
4	<b>Part Width</b> (see " <b>Part Width Calibration</b> " on page 92)
5	Part Detect (PD) - where the part is first detected by the sensor
6	Image Acquired - image is taken, inspection is performed
7	Rejecter Station - standard rejection point
8	Reject Confirm - second part sensor to determine whether a defective part was rejected

➤ **To set up Reject Confirm Calibration:**

**1 - Enable the Missed Reject alarm**

Go to the **Lane Alarm Configuration** (on page 76) to enable the alarm.

**2 - Calibrate Standard Reject Delay**

Calibrate the standard **reject delay** (see "**Reject Delay Calibration**" on page 113) using normal procedures.

**3 - Set up Reject Confirm**

Mount the Reject Confirm sensor at "X" distance beyond the rejector where "X" is distance in encoder ticks. For example, if there are 70 encoder pulses per inch, and the sensor is mounted five inches beyond the rejector, the Reject Confirm Delay would be set to 350.

❖ *Note: The maximum setting for Reject Confirm Delay is 1024. Mount the Reject Confirm sensor within that range of encoder ticks.*

When the Reject Confirm sensor sees a part that is not supposed to be there, it triggers the Missed Reject alarm.

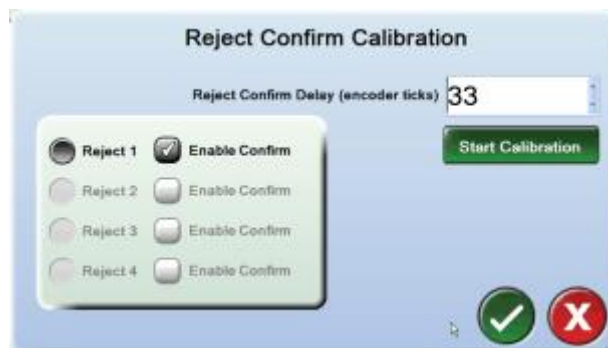

➤ **To calibrate Reject Confirm:**

1. From the Sensor Overview mode, right-click on a sensor button to view the **sensor menu** (on page 135).
2. Select Part Tracking, then select Reject Confirm Calibration.
3. Enable Reject Confirm.
4. Click the **Start Calibration** button.
5. Run a part through the system.

❖ *Tip: for best results, run about 10 parts through the system.*

6. When completed, click the **Stop Calibration** button. The system will determine the number of encoder pulses from the part detect sensor to the reject confirm sensor.

Reject Confirm Delay is computed.  $\text{Reject Confirm Delay} = (\text{number of pulses from Part Detect to Reject Confirm Sensor}) - \text{Reject Delay}$ .

# Chapter 10

## Software Utilities

This section includes various software utilities that assist with Windows settings, help and support from Pressco, and sensor configuration.

### Go Online at Startup

Use this option to have the Intellispec system go online to inspect when you start the software (or reboot the computer). This saves the extra step of putting each lane online, and it automatically puts the system into inspection mode if power is lost and the computer reboots as a result.

➤ *To use this option:*

1. Click the Home button to go to System Overview mode.
2. Click the Tools button to see the tools menu, then select System > Go Online at Startup. A check mark is displayed next to the menu item when this is enabled.



➤ *To disable this option:*

1. Click the Home button to go to System Overview mode.
2. Click the Tools button to see the tools menu, then select System > Go Online at Startup. The check mark is removed when this option is disabled.

### Adjusting Date and Time

Adjust the date and time for the Intellispec system. The Windows operating system time is also changed.

➤ *To adjust date and time:*

1. Go to System Overview mode by clicking the Home button .
2. Click the Tools button  to see the Tools menu.
3. Select System > Set Date and Time. The System Date and Time menu is displayed.

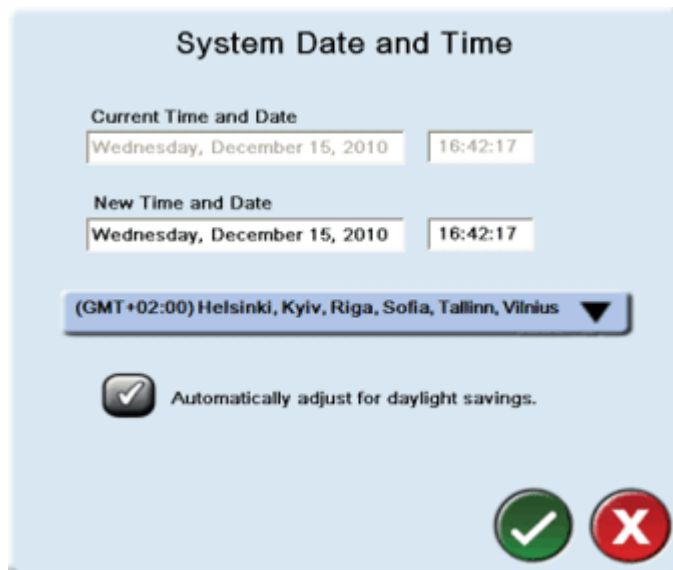



4. Choose your time zone from the drop-down menu.
5. Enable the check box to automatically adjust for daylight savings time if applicable.
6. Click the OK button  to save changes and exit.

---

## Setting up a printer

Configure a USB or networked printer to print Intellispec reports. The driver for the printer must be set up by an Administrator that has access to Windows.

➤ **To set up a printer:**

1. Go to System Overview mode by clicking the Home button .
2. Click the Tools button  to see the Tools menu.
3. Select System, then select Setup Printer. The printer configuration screen is displayed.

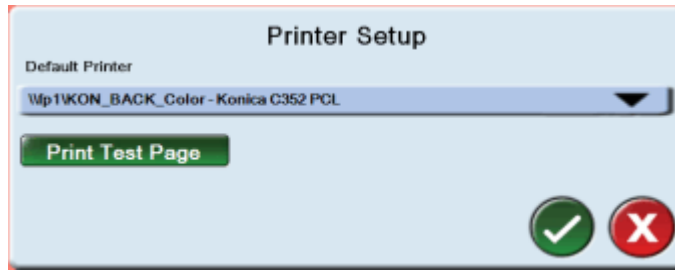

4. Select the printer to configure from the drop-down menu. The Intellispec system recognizes printers through the Windows drivers.
5. To test the printer, click the **Print Test Page** button. A basic "Intellispec Test Page" message is printed.
6. Click the OK button  to save changes and exit. The printer will be ready to use.

---

## Creating a Support Package

A support package is a set of files that is gathered by the Intellispec system to help determine system problems. You will send this package to Pressco service specialists so that they can troubleshoot your system.

❖ *Note: A Support Package does NOT contain images. You may be asked to send images with the support package for the most effective troubleshooting. At least one image per camera is desired. See **Saving Images** (on page 150).*

➤ **What you need:**

- **Mechanical keyboard (MKB)** (on page 35) to enter problem description
- USB flash drive (128MB or larger)
- If a Pressco Support representative sent you a ".pcf" file to acquire additional system information, then copy that file to the USB drive prior to connecting it to the Intellispec system

➤ **To set up for the support package procedure:**

- Connect the mechanical keyboard (MKB) to the convenience **USB port** (see "**USB Ports**" on page 35) on the side of the user interface.

➤ **To create the support package:**

1. Click the Help button  at the top of the screen. The help menu is displayed.

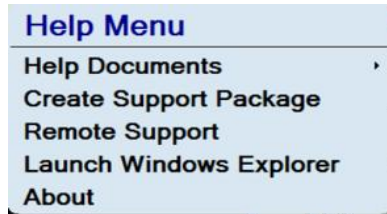

2. Select the Create Support Package option. The support package wizard is displayed.
3. Follow the instructions on screen.
4. Use the forward arrows  to move to the next screens.
5. When asked to describe the problem, use the mechanical keyboard to enter information.
6. Optional: At Step 3: Configure, check the Custom Configuration box. A .pcf file is custom Pressco configuration file that gathers additional information (beyond the standard Support Package) from your system. A Pressco Support representative will send you a .pcf file to load before you run the Support Package option.

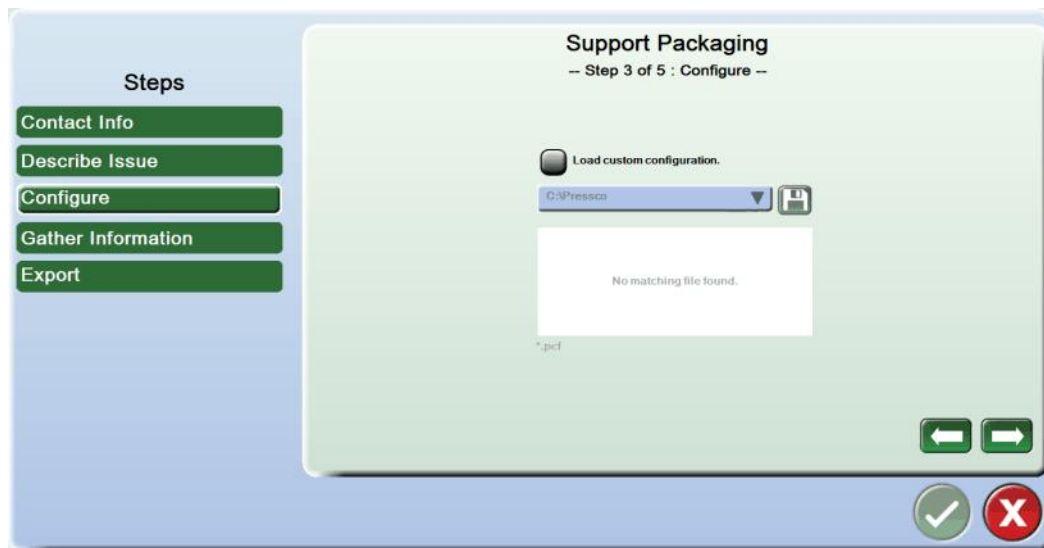

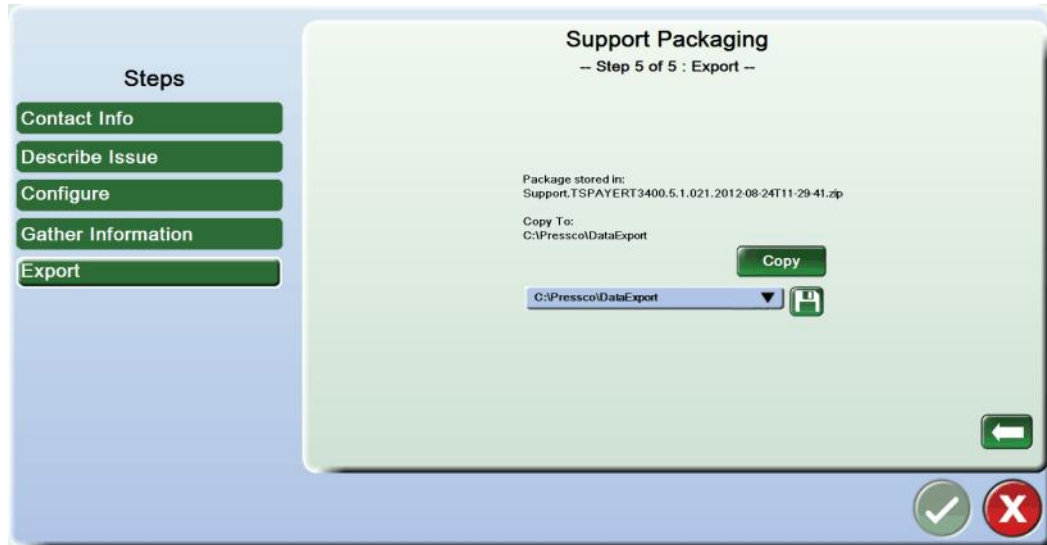

- a) If a Pressco Support representative sent you a .pcf file to acquire additional system information, then connect the USB device that contains the .pcf file.
- b) Click the disk icon  and browse to the location (usually your USB drive) where the .pcf file is stored. The system locates the .pcf file.

- When the steps are completed, verify that the Step 5: Export screen is displayed.

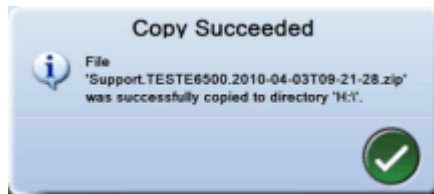

- Select the USB Flash Drive in the "Copy to:" location. You may need to remove the mechanical keyboard and then insert a USB flash drive into the USB port.
- Click the Copy button. The support package files are copied to the USB flash drive, then a "Copy Succeeded" message is displayed.



- Click the OK button  to continue.
- Click the OK button  at the bottom of the Support Packaging screen to exit.
- Remove the USB flash drive.
- Remove the mechanical keyboard (MKB).
- Send the support package files to Pressco.

➤ **To send the files to Pressco:**

- Copy the files that were saved, including images, from the USB drive to your computer.
- Send an e-mail to [techsupport@pressco.com](mailto:techsupport@pressco.com) (<mailto:techsupport@pressco.com>) and attach the support package files. Pressco service/ tech support will respond within one business day, if possible.

# Help - Remote Support

Remote Support is used to allow remote access to the Intellispec software. iTivity software is the method used by Pressco to provide remote system support if a Maintenance Agreement is purchased for that Intellispec system. With this software Pressco can log in and operate the Intellispec remotely.

➤ **You will need:**

- A functioning Intellispec (systems without power, or systems that are not capable of running Intellispec software, cannot be remotely accessed)
- An internet connection to your Intellispec. This can be established through your network, and is usually set up during installation. You may use DSL, Cable, Mobile Broadband, or plant network connections to connect to the internet. Contact your network administrator for help.

➤ **To use Remote Support:**

1. Notify a **Technical Support** (see "**How to Contact Pressco**" on page 373) representative that you require remote support. You will need to identify yourself, your location, and the Intellispec to which he should connect.
2. In the Intellispec software, Click the Help button . From the Help menu, select Remote Support.

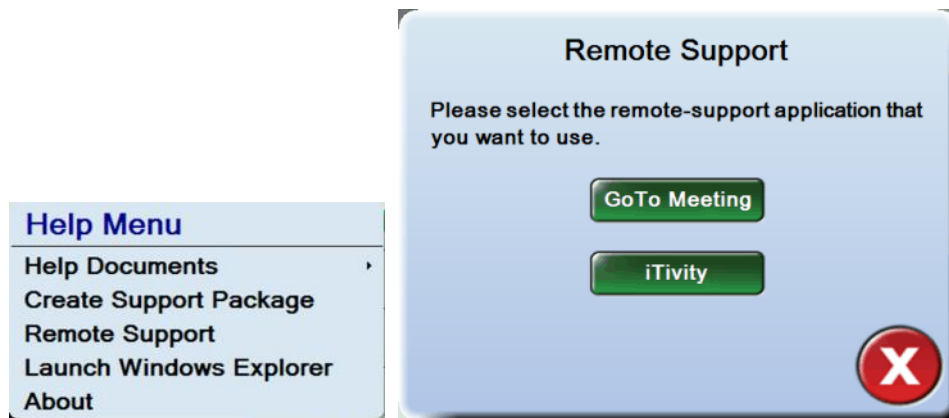

3. Select the **iTivity** button. If the system has a valid internet connection, the iTivity agent will attach to the server at Pressco. A connection status screen will appear indicating that the session has been established, as shown below. Intellispec systems are identified by computer name, which, in most cases, is the serial number.



- When the Pressco Tech Support representative is connected, you will be asked to give him control of your Intellispec system. Check Allow remote user MOUSE and KEYBOARD control and click Accept. The Tech Support representative will now perform the necessary troubleshooting of your system.

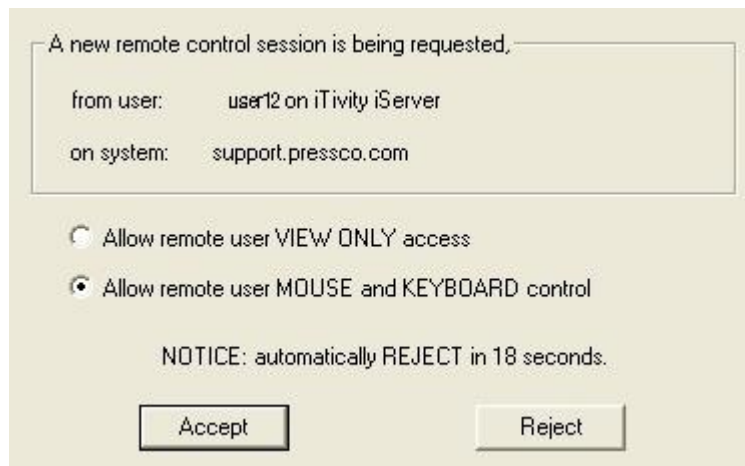

- When the Tech Support representative is finished, he will disconnect your Intellispec from the remote session.

If you need to disconnect your Intellispec from the remote session yourself, follow the steps below.

➤ **To disconnect from remote support:**

- Click the X in the upper right corner of the 'iTivity Live Support Agent Connection Status' box.
- When the system asks "Do you really wish to exit the iTivity Live Support Agent?" click OK. The system will be disconnected.



- Note: if you click the  button, the session will be disconnected, but this does not close the remote support program.
- If the session is disconnected and you want to allow Tech Support to be able to access your



system again, click the  button.



# Discovery Software - What is Discovery?

**Discovery** is software installed on the Intellispec hard drive that automatically looks for and identifies certain components installed on each lane. Specifically, the software identifies any sensors, cameras, lighting drivers, part trackers, and if used, Intellimass drivers that are attached to the system. Each one of these devices communicates with the Intellispec software via Cat -6 cabling and is assigned a unique MAC address.

❖ *Note: You should rarely need to use this software. However, if a new component (for example, camera) is installed on the system the software would be used to configure the new camera.*

Additionally, during system startup, if a previously configured component fails to communicate with the Intellispec software, the discovery software screen will automatically appear on the user interface, alerting you to the problem.

## Discovery software screen

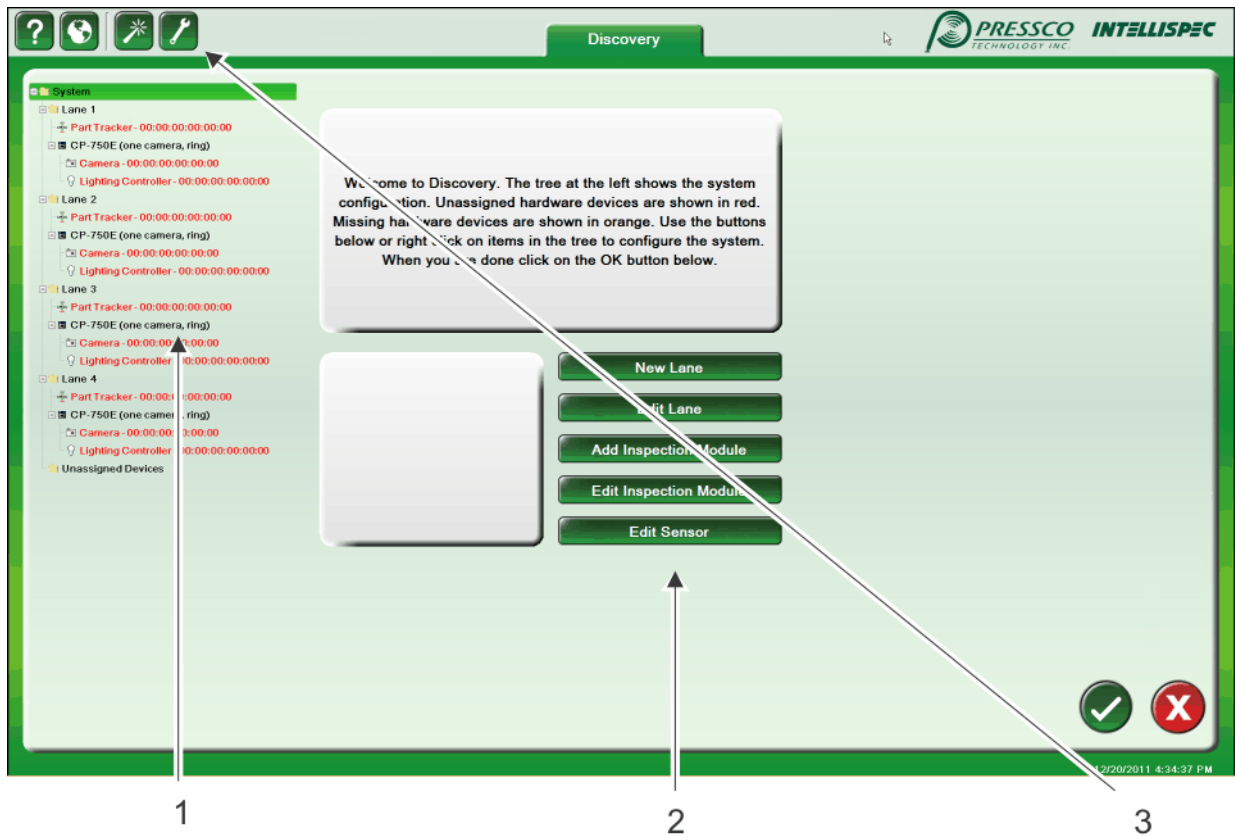

1	<p>The tree on the left side of the screen shows the system configuration including the lanes in the name and MAC address of each component in that lane.</p> <ul style="list-style-type: none"> <li>▪ Unassigned hardware devices are shown in red</li> <li>▪ Missing hardware devices are shown in orange</li> </ul>
2	<p>This menu allows you to perform specific actions, such as add or edit lanes or sensors, by clicking on the designated button.</p>
3	<p>The <b>Discovery menu toolbar</b> (on page 130) allows you to perform additional actions.</p>

## Discovery Menu Toolbar

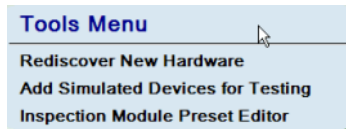

### Tools Menu

- **Rediscover New Hardware** - when this command is initiated this software will perform another search of all hardware communicating with the Intellispec and displayed in the tree on the left side of the screen.
- **Add Simulated Devices for Testing** - this is software used by Pressco engineers to assign devices on an Intellitrainer.\*
- **Inspection Module Preset Editor** - this is software used by Pressco engineers to assign new components as they become available.



**Wizard Menu** - lists the same choices as those listed in the green buttons in the center of the screen.



**Language Menu** - displays language choices that can be displayed.



**Help** - provides software and systems for users.

\*Intellitrainer = portable Intellispec training computer.

## Discovery - access and use

- The initial configuration of all hardware devices will be performed by the Pressco installer, and it is not anticipated that plant personnel will normally need to use Discovery software.
- The Discovery screen is automatically displayed during system startup anytime a hardware device that was previously configured is not communicating with the Intellispec software.
- If you need to run the Discovery screen manually, you must log in as an Administrator, shut down the Intellispec software, and run the Discovery program from Windows
- An **example** of a situation where plant personnel may use the Discovery software and actions to be taken is described next:
  - During system startup camera does not communicate with the Intellispec software
  - The Discovery screen sees this as a missing piece of hardware and automatically displays the Discovery screen. The configuration tree shows the camera in the expected location but displayed in orange, indicating that hardware device is missing.
  - As a first step you should open the tools menu icon and select "Rediscover New Hardware." This will trigger the software to search for the missing camera.
  - If the camera re-establishes communication, as seen by the camera name changing to black, you can close the discovery software and resume normal operation.
  - If the camera does not re-establish communication this indicates a hardware problem and the camera will most likely need to be replaced.

# Favorites Menu

Access the Favorites menu from System Overview, Lane Overview, or Sensor Overview menu. Click the Favorites button  from the toolbar to see the menu.

❖ *Note: Some menu items are only available to advanced level users.*

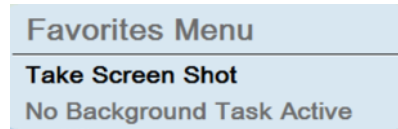

This menu allows you to access the following utilities:

**Take Screen Shot** (on page 131)

Manage **Background Tasks** (on page 131)

## Take Screen Shot

This utility allows you to capture an Intellispec screen image. This is different from saving individual part images through the **Save Image** (see "**Saving Images Through the Sensor Menu**" on page 150) function. A screen shot is useful to illustrate a problem to technical support, or to capture settings for future setup.





### ➤ *To capture the current full Intellispec screen:*

1. Click the Favorites button  to access the Favorites menu.
2. Select the Take Screen Shot option. An onscreen keyboard is displayed with a default image name.
3. Re-name the screen shot if desired.
4. Click OK to save the image. The image is saved as a Portable Network Graphic (.png) file to C:\Pressco\DataExport\ScreenShots.

## Background Tasks

You can control the Intellispec system's background tasks. If you are saving or copying several images, especially to a USB device, this process is slow. Therefore the Intellispec considers it a background task. The system will continue to inspect and perform regular tasks in the foreground. You may stop or remove certain background tasks if desired.

Background task management is found under the Favorites icon (except in System Overview mode). You may see different icons depending on whether the system is performing background tasks.

1		Normal. No background tasks in use.
2		One or more background task is running. None is complete.
3		One or more background task is running. At least one is complete.
4		All background tasks are complete. This icon will appear on screen until you "Remove All" tasks from the system using the Manage Background Tasks menu.

When at least one background task is active, the Manage Background Tasks menu item becomes active in the Favorites menu. Click either icon [item 2 or 3 above] to access the menu.



Select the Manage Background Tasks option from the Favorites menu to cancel or remove one or more tasks. Removing a task gets rid of all information about the task.

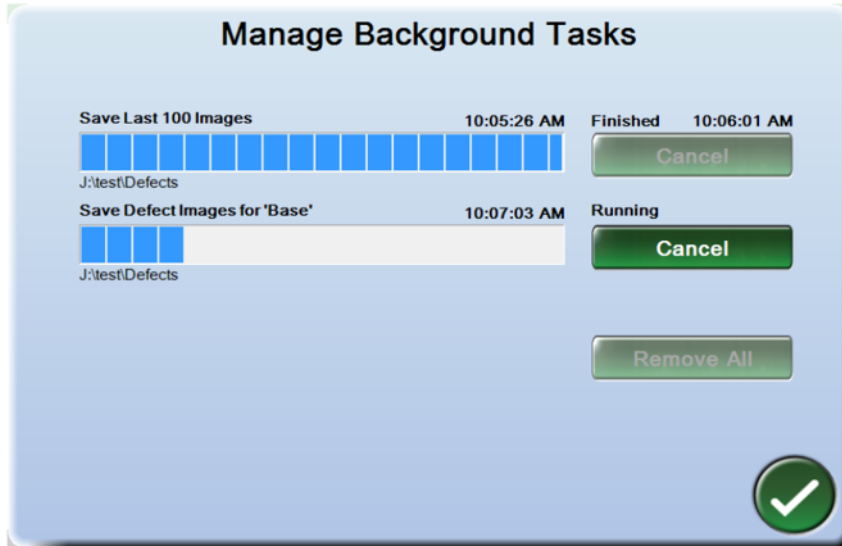

Notes:

- Each lane maintains its own list of background tasks. If you start a task on Lane 1, you must manage the task from Lane 1.
- You will not be able to close the dialog box until the task is complete or canceled. This prevents errors from occurring in the system.

### ***Saving images to USB using the Retro-Spec interface***

When you are editing an inspection, you might save image sets to a USB device. This is not a background task, and you will not be able to perform other tasks while saving the images. However, you can cancel the task if necessary (see menu shown below). You will not be able to close the dialog box until the task is complete. This prevents errors from occurring in the system.

The sequence to save the images is (see illustration below): 1 - click the Save button. 2 - Choose the USB device. 3 - Save a data set (A or B). For more information about this menu see *Saving Images through the Retro-Spec interface* (on page 153).

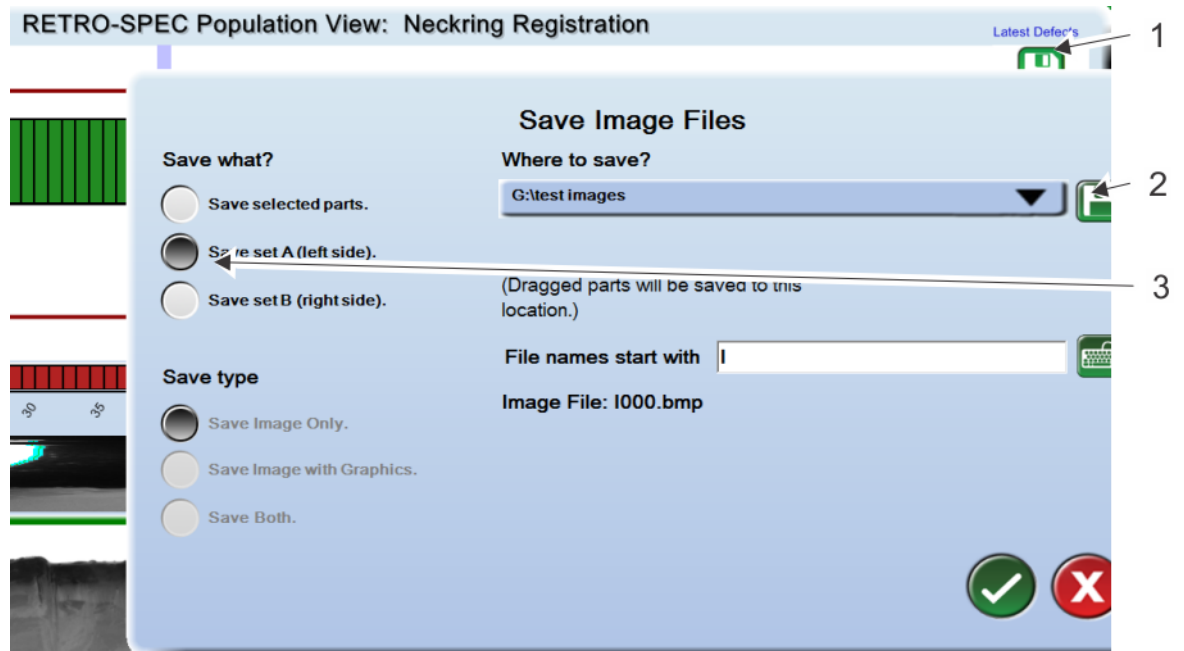

You may cancel the task if necessary.

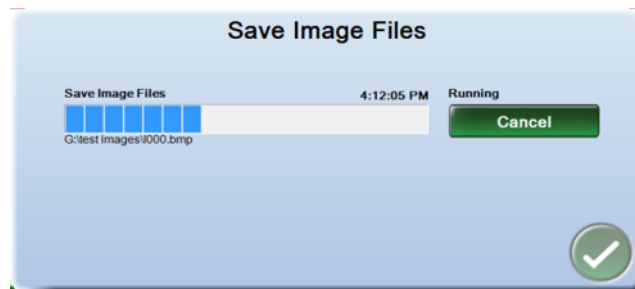



# Chapter 11

## Lighting and Imaging

This section includes how to adjust lighting, how to save and load images, how to use Offline imaging, and how to use Image Analysis.

### Sensor menu

The Sensor Menu provides access to part tracking, lighting, and image options. Right-click the Sensor button to view the Sensor menu from the Lane Overview or Sensor Overview mode. The items at the bottom of the menu are only available in Sensor Overview mode.

❖ *Note: the lane must be offline to access the items in the Sensor menu.*

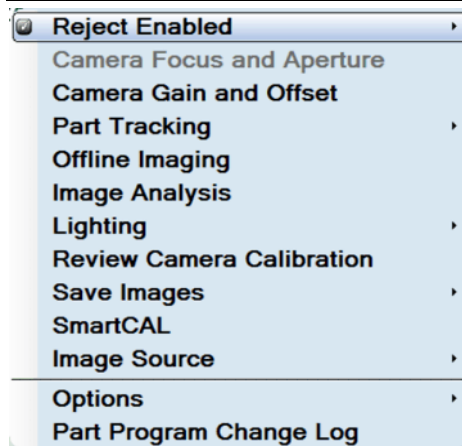

The items in the Sensor menu are as follows:

#### Reject Enabled

(Toggles to Reject Disabled) This option enables or disables the rejecter for the **Sensor** only. If you disable a sensor and put the system online, you will see a message that a rejecter is disabled. See also *Rejector Enable/ Disable* (on page 103).

#### Camera Focus and Aperture (on page 136)

Calibrate the focus and aperture of some cameras. This menu item will be grayed out if your system does not have cameras that can be adjusted through the software.

#### Camera Gain and Offset

❖ *Note: This menu normally should not be adjusted. It is usually set by the Pressco installer. Improper adjustment of these parameters can cause a distortion of the image.*

- Camera gain is the amplification of the video signal
- Offset adjusts the grayscale reference values

#### Part Tracking

Opens Part Tracking options for:

- *Part Present Delay Calibration* (on page 110)
- *Part Present Delay with Encoder* (on page 112)
- *Reject Delay Calibration* (on page 113)
- *Reject Confirm Calibration* (see "*Reject Confirm Calibration (Optional)*" on page 120)
- *Part Width Calibration* (on page 92)

### **Offline Imaging (on page 137)**

Choose how the Intellispec acquires images when the lane is offline.

### **Image Analysis (on page 138)**

This tool displays the gray shade value for any pixel or group of pixels in your image. This is useful in programming part programs or setting up lighting. You can measure grayscale values of pixels in horizontal or vertical lines, or over a circle. Image Analysis also allows you to calibrate the pixel scale for the sensor.

### **Lighting**

Opens lighting options: **Basic Adjust Lighting** (on page 141) and **Advanced Adjust Lighting** (on page 142).

### **Review Camera Calibration (on page 144)**

This tool shows how the current camera is calibrated - the number of image pixels to an actual measurement on your part. Calibration is used in measurement inspections.

### **Save Images (see "Saving Images Through the Sensor Menu" on page 150)**

Allows you to save captured images to disk.

### **SmartCAL**

SmartCAL is a tool that allows you to load a set of images, run them with the current part program, and make sure the part program is passing or rejecting parts as you expect.

### **Image Source (on page 145)**

Allows you to choose which images to display, and select between live sensor images or saved images.

The two following options are available from Sensor Overview mode.

### **Options (see "Options (sensor menu)" on page 177)**

Provides different inspection tree views.

### **Part Program Change Log (on page 174)**

Display the Part Program Change Log. This lists the inspections and the edit history for each. You can view all inspections from one sensor, other sensors, or other part programs.

## **Camera Focus and Aperture**

This menu allows you to adjust the focus and aperture of some cameras. It is only available when the lane is offline.

❖ *Note: only some cameras support this feature. They contain built-in motors to make these adjustments. The Camera Focus and Aperture menu item will be grayed out in the Sensor menu if your system does not support this feature.*

➤ **To get to this screen:**

From the Lane or Sensor Overview screen, right-click the Sensor button to see the Sensor menu, then select Camera Focus and Aperture from the menu.

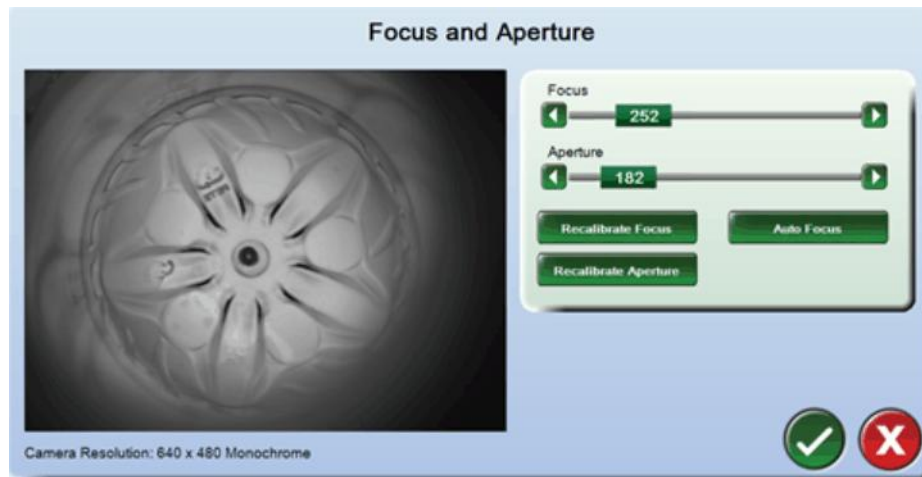

Make adjustments as necessary.

**Focus slider**

Sets the focus position of the lens.

**Aperture slider**

Sets the aperture position of the lens.

**Recalibrate/ Calibrate Focus**

Determines and sets the usable range of focus positions for the lens.

**Recalibrate/ Calibrate Aperture**

Determines and sets the usable range of aperture positions for the lens.

**Auto Focus**

Automatically determines and sets the best focus position for the image.

## Offline Imaging

Choose how the Intellispec acquires images when the lane is offline.



### Triggered Mode

- **Single Image** – using the part detect sensor, an individual picture is taken every time the button is clicked.
- **Run** – using input from the part detect sensor, pictures are taken continuously at the rate set in "Image Update Interval."

### Immediate Mode

- **Single Image** – NOT using the part detect sensor, an individual picture is taken every time the button is clicked.
- **Run** – the camera takes a continuous picture, the light array is on, and you instantly see whatever is under the camera.

## Image Analysis

This tool displays the gray shade value for any pixel or group of pixels in your image. This is useful in programming part programs or setting up lighting. You can measure grayscale values of pixels in horizontal or vertical lines, or over a circle. Image Analysis also allows you to calibrate the pixel scale for the sensor.

#### ➤ To get to Image Analysis:

- Make sure the lane is offline. Image Analysis is not available in online mode.
- Right-click an image in the Sensor Overview screen to display the zoom and image options. Choose Image Analysis from the menu.

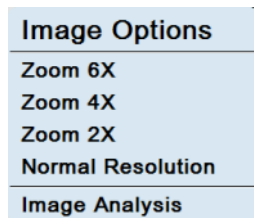

- OR -

- Right-click the **Sensor menu** (on page 135) and choose Image Analysis from the menu.

❖ *Note: you must have proper user access to use Image Analysis; otherwise, the option will be grayed out*

The Image Analysis screen is displayed. The components of this screen are described below.

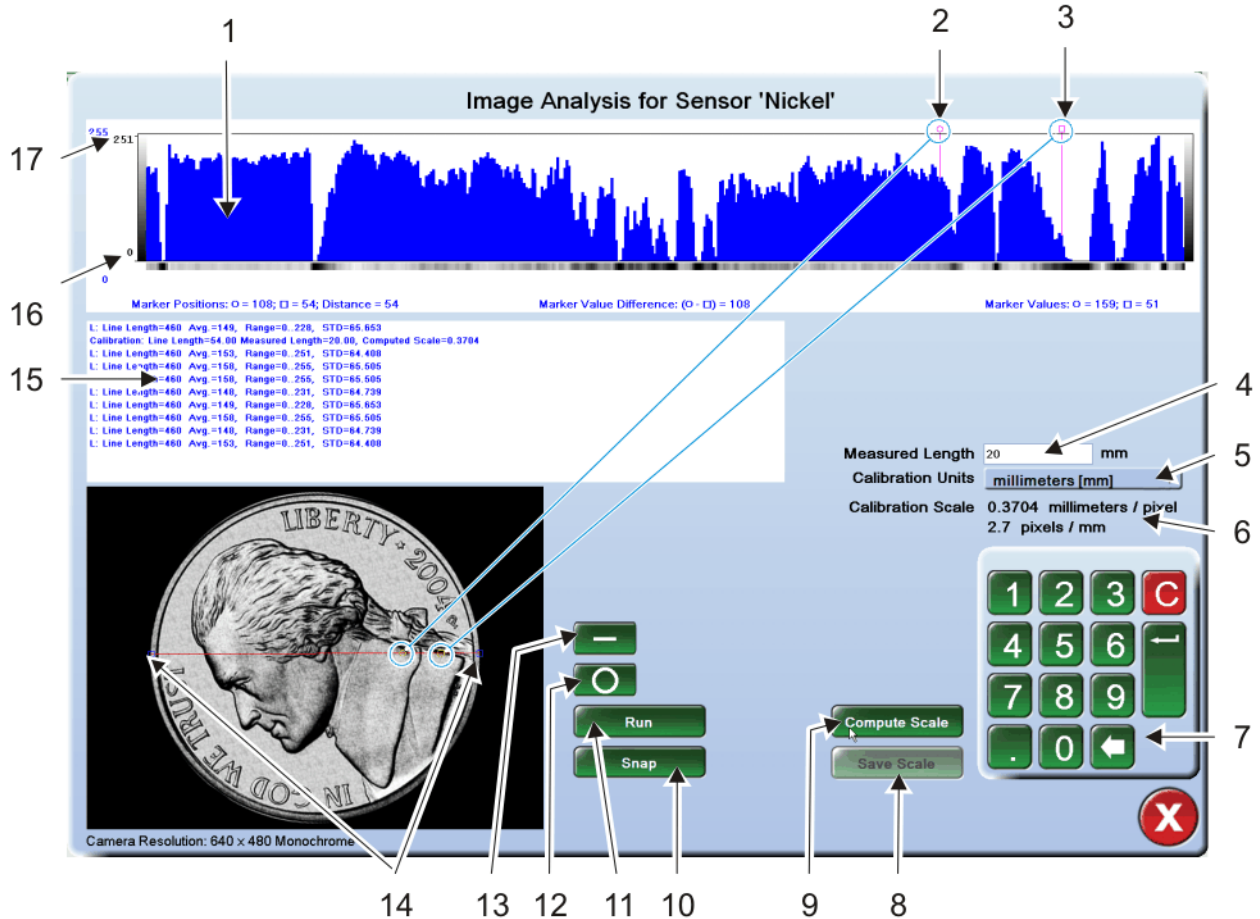

1	Image analysis graph displays gray shade value for each pixel along the line or circle. The gray shade values of the line, or unwrapped circle, are displayed directly below the graph.
2	Circle marker - click and drag the circle to any point on the line or circle (either in the image or in the graph)
3	Square marker - click and drag the square to any point on the line or circle (either in the image or in the graph)
4	Measure your actual part with a ruler or calipers and enter the measured value in this box. Place a line or circle on the image, covering the same area you measured. <b>If using a line:</b> place the end boxes of the line on the same area on the image that you used to measure the part. This will measure length. <b>If using a circle:</b> place the circle on the image over the same location you used to measure your part. This will measure the part's diameter.
5	Choose your calibration units that you used to measure your part
6	This is a computed number that is updated after you click the <b>Compute Scale</b> button. It computes the units of measure per pixel, and shows the number of pixels measured by the line or circle.
7	Use this keypad to enter the measured value of your part.
8	<b>Save Scale</b> - (available after you Compute the scale) Click this button to save the number of pixels per unit of measure to the sensor file. This calibration unit can then be used in inspections such as Measurement or Distance.

9	<b>Compute Scale</b> - Click this button <b>after</b> you have entered your measured value [item 4] and set up your line or circle. The system computes the units of measure per pixel.
10	Click <b>Snap</b> to acquire one new image. This option is only available if you accessed Image Analysis by right-clicking the Sensor button.
11	Click <b>Run</b> to continually snap new images. Different images are only displayed if your production line is running. This option is only available if you accessed Image Analysis by right-clicking the Sensor button.
12	Click the circle button to view gray shades along a circle
13	Click the line button to view gray shades along a line
14	Click and drag an end square to change the size or location of the line. If you are using a circle for image analysis, use the middle yellow square to re-position the circle on the image.
15	Values for each image are displayed so that you can see the difference between images
16	The lowest gray shade value along the line or circle
17	The highest gray shade value along the line or circle

Under the graph, the information displayed is as follows:

#### Marker Positions

The distance in pixels that the square or circle markers are from the beginning of the reference (red) line or circle.

#### Marker Value Difference

The difference in gray shade between the values of the two markers.

#### Marker Values

Gray shades of markers.

## Calibrating the Image Pixel Scale

### Using Image Analysis

Image Analysis can be used to enter your actual measured values of your part and compute the units of measure per pixel. This is called Pixel Scale. This calibration can be used for any inspection on that sensor.

#### ➤ *To compute the pixel scale (refer to the illustration for Image Analysis (on page 138)):*

1. Using a known good part, measure the length or diameter of an area on your part.
2. Enter that value into the Measured box [item 4].
3. Place a line or circle on the part image in Image Analysis over the same location used to measure your part. Place the markers of the line, or a circle at the edges where you want the system to measure your part.
4. Click the Compute Scale button [item 9]. The system computes the pixel scale and displays the values [item 6].
5. To save the scale to the Sensor file, click the Save Scale button. The pixel scale is saved with the sensor and can be used for any inspection on that sensor.

### Using an inspection

Pixel scale can be calibrated for an individual inspection or sensor. When **Save Calibration** is used in these inspections, you can use the calibrated information in other inspections for that sensor. The inspections that use pixel scale calibration are:

- **Measurement** (on page 261)
- **Fill Height** (on page 269)
- **Distance** (on page 287)

See the descriptions for the individual inspections using the links provided.

## Basic Adjust Lighting

The Basic lighting provides most of the lighting adjustments you will use.

❖ *Note: lighting must be adjusted while the lane is offline.*

### ➤ To get to this screen:

1. From the Lane Overview or Sensor Overview screen, right-click over the desired sensor button.
2. Select Lighting, then select Basic Adjust Lighting. The Basic Lighting screen is displayed.

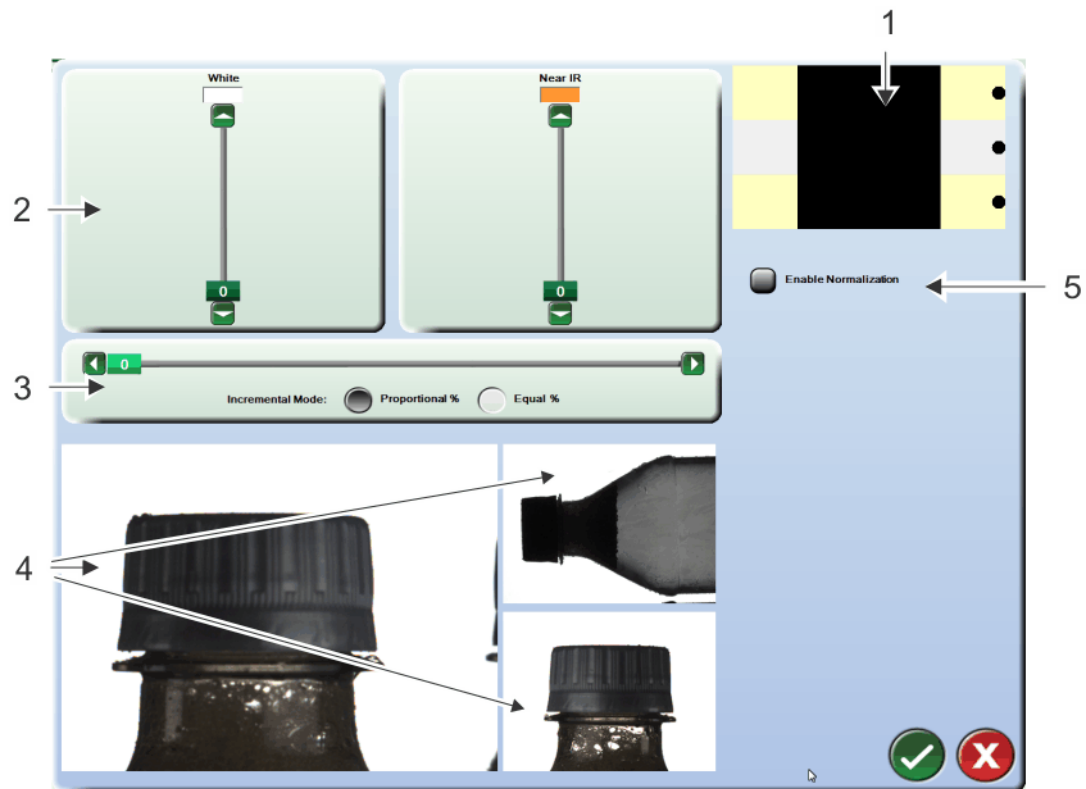

1	Upper right corner displays each zone. Click a zone to adjust it. You can select a single zone or multiple zones at any one time. As lighting is changed, the zone and the button next to it change color.
2	Separate slider bars for each color (red, green, blue, and infrared) allow individual adjustment.
3	Incremental mode <b>Proportional %</b> - Moving the slider bar adjusts all colors but maintains the current percentage of each color. <b>Equal % lighting</b> - Each color is adjusted by the same amount.
4	Click any image (if applicable to your system) to select the camera to adjust its lighting.
5	<b>Enable Normalization</b> - (in some systems, Disable Normalization). For most applications leave normalization disabled. If you are modifying a part program that has normalization enabled, then leave it enabled. This function was previously used to limit the brightness of certain LEDs. It is no longer required.

## Advanced Adjust Lighting

This screen provides additional lighting setup. This is mostly used by Pressco engineers, or for making infrequently performed specialized settings.

❖ *Note: lighting must be adjusted while the lane is offline.*

### ➤ To get to this screen:

1. From the Lane Overview or Sensor Overview screen, right-click over the desired sensor button.
2. Select Lighting, then select Advanced Adjust Lighting. The Advanced Lighting screen is displayed.

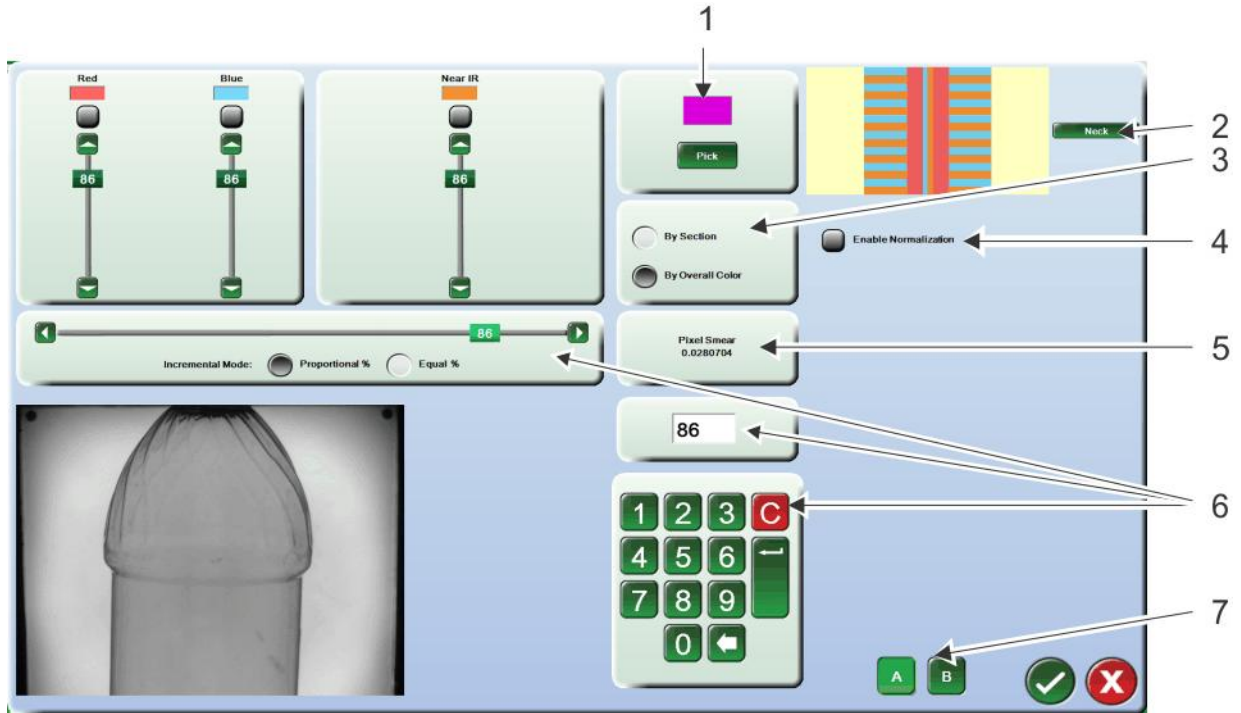

1	Opens a color palette and allows you to choose preselected colors.
2	If your inspection module has different lighting arrays, click one of the array buttons to adjust lighting by zone.
3	<b>By Section</b> - Allows you to change lighting by each individual section. <b>By Color</b> - Allows you to change lighting for multiple sections at once.
4	<b>Enable Normalization</b> - (in some systems, Disable Normalization). For most applications leave normalization disabled. If you are modifying a part program that has normalization enabled, then leave it enabled. This function was previously used to limit the brightness of certain LEDs. It is no longer required.
5	<b>Pixel Smear</b> - The Intellispec computes the amount of pixel smear based on lighting, image size, and part rate. It should be kept below one.
6	<b>On-screen keypad (OSK)</b> - enter the percentage of color. Type the number in the empty box (using the onscreen keypad). This also moves the percentage slider.
7	<b>A/B buttons</b> - Allows you to set up two different lighting settings for the same part so you can view each and compare.

## Advanced adjust lighting - zones

When you select one of the array buttons from the Advanced Lighting screen, you can adjust each zone independently.

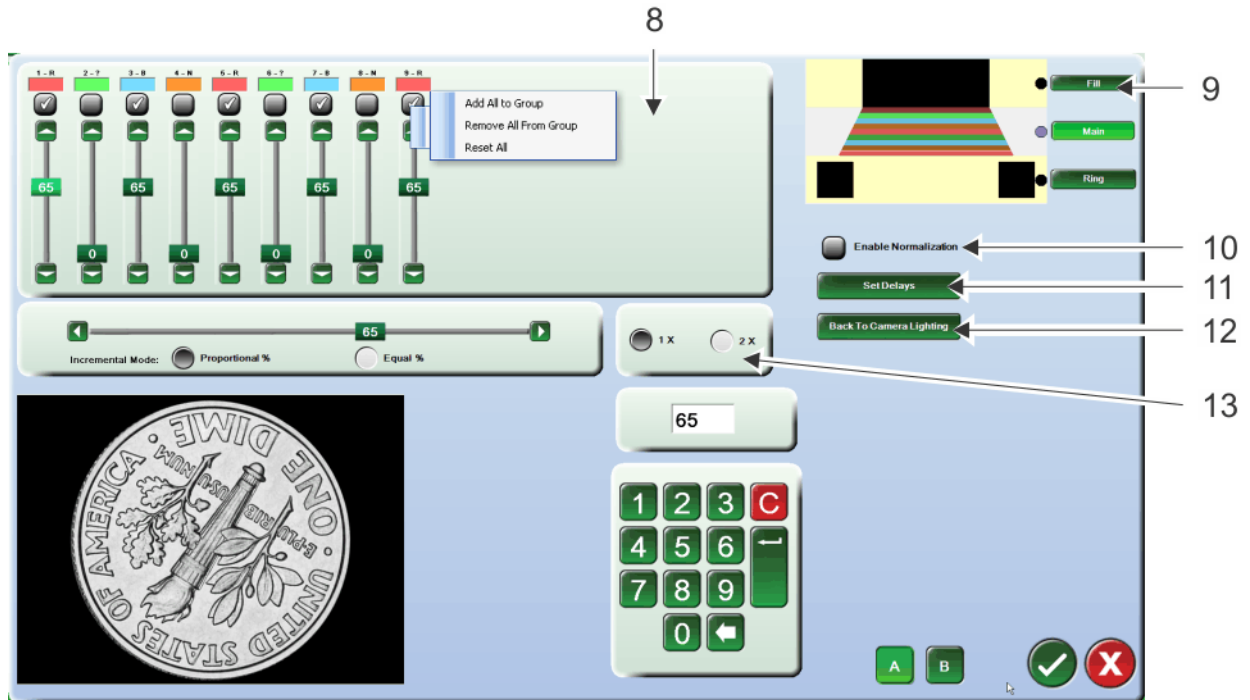

8	<p>Adjust any zone within the light array. Options:</p> <ul style="list-style-type: none"> <li>Adjust any zone with the slider or arrows</li> <li>Select several zones by checking their gray box to adjust those zones as a group (intensity will be the same for the whole group)</li> <li>Right-click over any zone for options to add all zones to the group, remove all zones from the group, or reset all zones to zero</li> </ul>
9	Click another array button to adjust lighting zones for that array
10	<b>Enable Normalization</b> - (in some systems, Disable Normalization). For most applications leave normalization disabled. If you are modifying a part program that has normalization enabled, then leave it enabled. This function was previously used to limit the brightness of certain LEDs. It is no longer required.
11	<b>Set Delay</b> (see " <i>Advanced adjust lighting - set delay</i> " on page 143) is only available in a BNS application.
12	Click the <b>Back to Camera Lighting</b> button to go back to the main Advanced Adjust lighting screen
13	1X - 2X is an intensity multiplier. 1X is the normal setting. 2X doubles the intensity without having to adjust the intensity through the sliders. Maximum intensity is 100% - if a slider is already at 100%, then the intensity will not be doubled.

## Advanced adjust lighting - set delay

Setting the zone delay is only available in a BNS application. It provides a strobe delay on the light control board for the Neck camera, so that the Neck lighting fires after the Base camera (and not at the same time). Since the Base and Neck part present signal occurs at the same time, a lighting delay is required so that the Base is lit separately from the Neck.

❖ *Note: this setting is normally done in the Pressco factory. You should not need to adjust it.*

➤ **To get to this screen:**

1. From a Lane Overview or Sensor Overview screen, right-click over a Sensor button to see the sensor menu.
2. Select Lighting > Advanced Adjust Lighting.
3. In the upper right corner of the lighting screen, click one of the array buttons to go to the zone adjustment screen.
4. Click the Set Delays button. The Zone Delays menu is displayed.

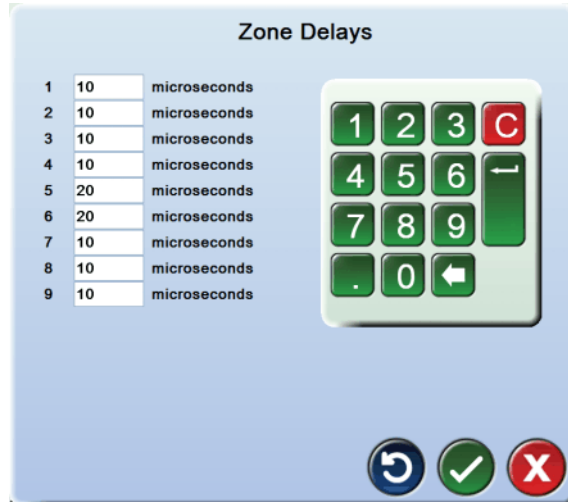

➤ **To adjust zone delay:**

1. Enter the number of microseconds for each zone with the OSK. The normal setting for the Neck camera is 350 microseconds on each zone.
2. Click the OK button  to save changes and exit the menu.

❖ *Note: this delay is separate from the Strobe Delay set in **Part Present Delay Calibration** (on page 110).*

## Review Camera Calibration

This menu allows you to switch between inches and millimeters, select a custom scale, or go back to pixels. If you switch between inches and millimeters, the pixel scale is automatically converted. Calibration to pixel scale is performed in **Image Analysis** (on page 138) or some inspections such as Measurement or Fill Height. Calibration is used to compute measurements on a part.

The unit you select in this menu is displayed in the Inspection menus:  for pixels, mm for millimeters, " for inches, or [ ] blank for custom units.

To see this menu, right-click over the Sensor button in Lane Overview or Sensor Overview modes > select Review Camera Calibration.

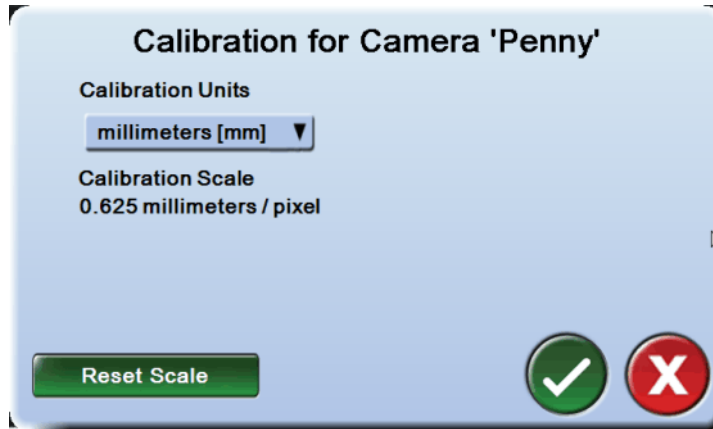

Notes:

- If you switch from mm to inches, or inches to mm, the scale is converted for you. However, if you switch to custom or pixels between mm and inches, then the scale is not adjusted for you.
- If you switch to pixels, the scale is set to 1.0. The scale will revert back to your calibrated value if you switch from pixels to another unit.
- The **Reset Scale** button sets the scale to 1.0 for any unit you have selected.

## Image Source

This tool allows you to choose which images to display for the lane or sensor. You can load images to simulate inspection if your production line is not running, or choose live images from the sensor.

To see this menu, right-click the Sensor button from Lane Overview or Sensor Overview mode, then select Image Source.

❖ *Note: you can also see most of the items from this menu by clicking the Tools button in Lane Overview mode, selecting Lane Setup, then selecting Image Source.*

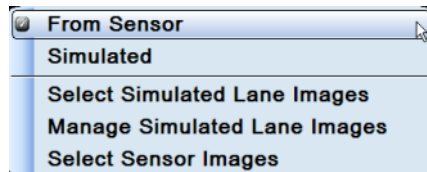

### From Sensor

The system displays the live images from the current sensor.

### Simulated

The system displays images you have previously saved to disk. When you select Simulated Images, the following happens:

- All rejectors for the current lane are disabled.
- The name of the sensor(s) is displayed in **red** to indicate that the rejector is disabled.
- You must specify images through one of the following options: Select Simulated Lane Images (PDL), Manage Simulated Lane Images (PDL), or Select Sensor Images.

### Select Simulated Lane Images

*Load a PDL file* (on page 147)

*Manage Simulated Lane Images* (see "*Manage Simulated Lane Images (PDL)*" on page 146) (PDL)

*Select Sensor Images* (on page 149)

## Manage Simulated Lane Images (PDL)

Create a Pressco Data List file [.PDL] that lists the images to load. This way, you can easily load the same images another time. It allows you to save and load images for all sensors within the lane.

First, you must save a set of images; choose from one of the options: **How to Save Images** (see "Saving Images" on page 150)

To see this menu, right-click on a Sensor button in Lane or Sensor Overview mode to see the **Sensor menu** (on page 135), then choose **Image Source** (on page 145), then choose **Manage Simulated Image Files** from the menu.

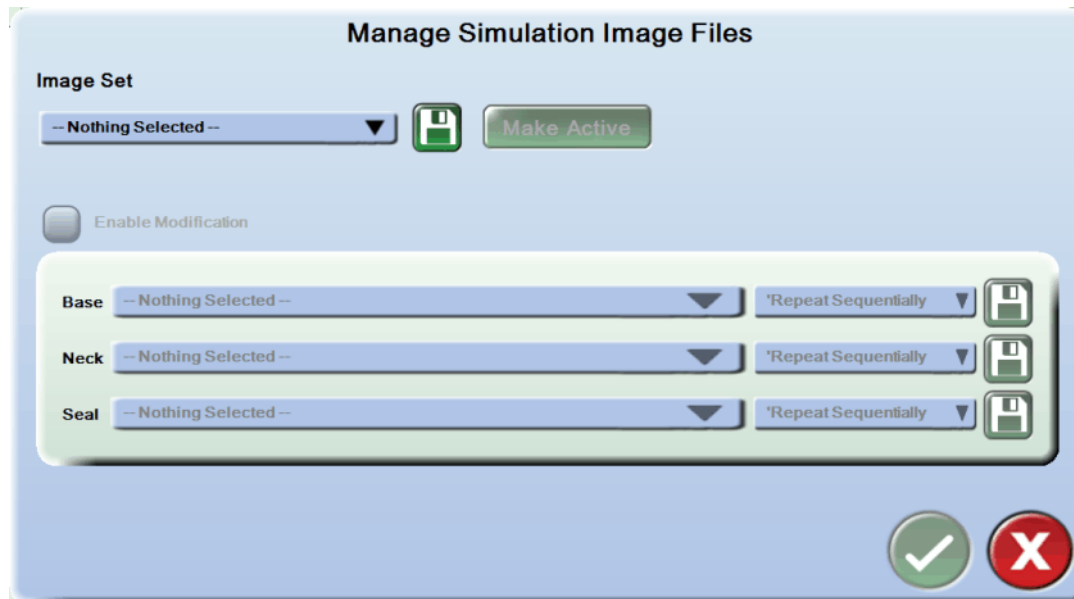

### ➤ To create a new PDL file:

❖ *Note: this process creates one file where you can load images from all sensors within the lane.*

1. Click the disk icon  under **Image Set**.
2. In the **Select Lane Simulation File** screen, click the **New** button. An on-screen keyboard is presented.

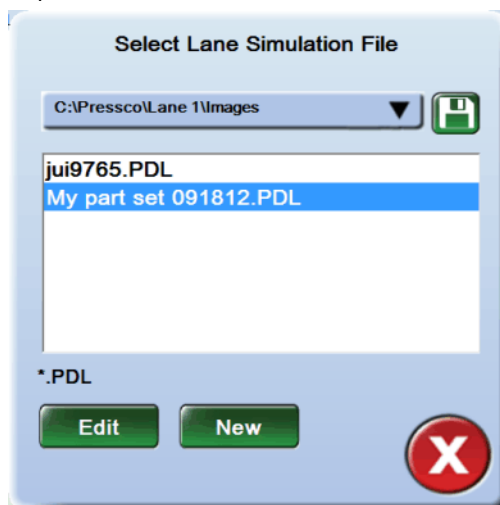

3. Type a name for the image file and click the OK button from the on-screen keyboard to save the file. A file is created and saved in the default directory for the sensor (example: C:\Pressco\Lane 1\Images). The file path will be displayed in the **Image Set** drop-down menu.
4. To add images to the set, highlight the file name in the **Select Lane Simulation File** screen. The **Edit** button becomes active.

5. Click the **Edit** button. The Select Lane Simulation File screen closes, and the selected file name is displayed in the **Manage Simulation Image Files** screen.
6. Check the **Enable Modification** box, then click the disk icon  next to the 'Repeat Sequentially' drop-down menu. The **Select Sensor Images** screen is displayed.
7. Select images for the set using the instructions under the **Select Sensor Images** (on page 149) section, and click the OK button to save.
8. Choose how to display the images using the drop-down menu on the right of the screen.
  - **Repeat Sequentially** - displays the images in order by file name, starting from the first image file, repeating as long as the lane is online.
  - **Repeat Randomly** - displays the images in a random order, repeating as long as the lane is online.
  - **Run Once** - not currently supported.
9. Click the **Make Active** button. A check mark is displayed next to the PDL file name, and the file is activated.
10. Exit from the Manage Simulation Image Files screen.

Next, display the list of images.

➤ **To display the simulation images:**

1. Make sure **Simulated** is selected in the sensor menu: Right-click over a sensor button > choose Image Source > Simulated. A check mark next to Simulated indicates the system will display images from disk, and not the camera.
2. To clear the previous images from the lane, right-click over the **Statistics menu** (on page 40), and select Clear Lane Statistics and Clear Images.
3. The next time you put the lane online, the selected PDL images will be displayed.

## Load a PDL file

This topic assumes that your system already has PDL files on the hard disk. If not, create a new PDL file: **Manage Simulated Lane Images** (see "**Manage Simulated Lane Images (PDL)**" on page 146).

➤ **To load a previously created PDL file:**

1. Take the lane offline (if necessary).
2. In Lane Overview or Sensor Overview mode, right-click a sensor button to see the **Sensor menu** (on page 135).
3. Make sure **Simulated** is selected in the sensor menu: Choose Image Source > Simulated. A check mark next to Simulated indicates the system will display images from disk, and not the camera.
4. Right-click over the sensor button to view the sensor menu again. Choose Image Source > Select Simulated Lane Images. The Select Lane Simulation File screen is displayed.

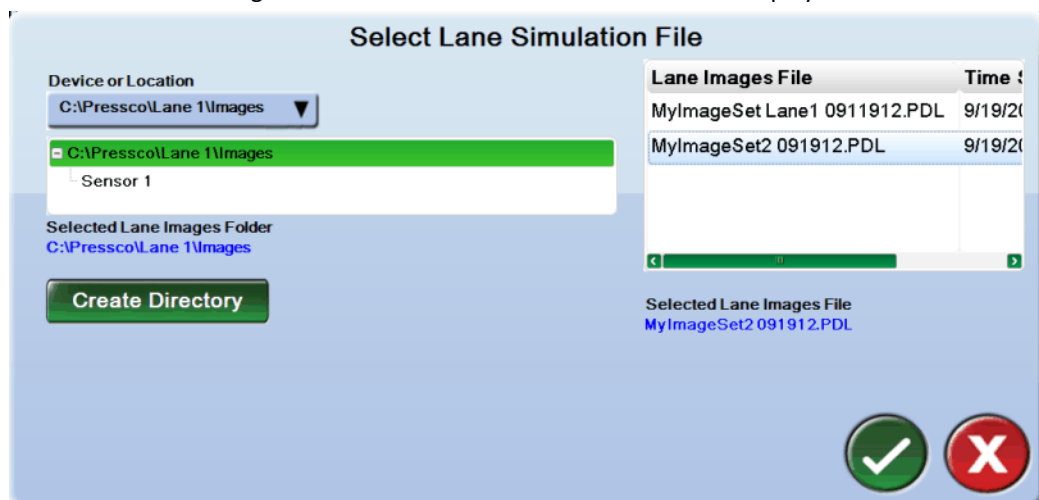

5. In the right side of the screen, select the PDL file to display. Browse to a different directory (in the left side of the screen) if necessary. Click the OK button  to save the selection and exit the screen.
6. To clear the previous images from the lane, right-click over the **Statistics menu** (on page 40), and select Clear Lane Statistics and Clear Images.
7. The next time you put the lane online, the selected PDL images will be displayed.

## Edit a PDL file

You can edit an existing PDL file by adding or deleting images. If your system does not already have a PDL file, create one: **Manage Simulated Lane Images** (see "**Manage Simulated Lane Images (PDL)**" on page 146).

### ➤ To edit an existing PDL file:

1. Go to the **Manage Simulation Image Files** screen: Right-click a sensor button > choose Image Source > Manage Simulated Lane Images.
2. In the **Manage Simulation Image Files** screen, click the drop-down menu under **Image Set**, and select the PDL file to edit. The PDL file name is displayed in the Image Set box.
3. Check the **Enable Modification** box. The list of images in the PDL file is displayed in the drop down menu next to the sensor name. You can add or delete images as desired.

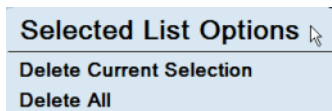

### ➤ To delete images:

1. Follow the instructions "To edit an existing PDL file" above.
2. Click the drop-down menu next to the sensor name to display the list of images in the PDL file, and select an image name to delete. Release the trackball buttons or click outside of the menu to collapse the drop-down menu.
3. Right-click over the drop-down menu next to the sensor name to see the **Selected List Options** menu.



4. From the menu, choose to delete the currently selected image or all the images in the PDL file. The image(s) is deleted.
5. Click the OK button  to save the changes and exit.

### ➤ To add images:

1. Follow the instructions "To edit an existing PDL file" above.
2. Click the disk icon  next to the 'Repeat Sequentially' drop-down menu. The **Select Sensor Images** (on page 149) screen is displayed.
3. Add or remove images by browsing through the directories, using the **Add** or **Remove** buttons.
4. Exit from the **Select Sensor Images** screen. The modified list of images is displayed in the drop-down menu next to the sensor name in the Manage Simulation Image Files screen.
5. Click the OK button  to save the changes and exit.

## Select Sensor Images

Select individual images or a group of images to display on the **sensor**. (To select images for all sensors within a lane, use **Select Simulated Lane Images** (see "**Image Source**" on page 145)) To see this menu, right-click on a Sensor button to see the sensor menu, then choose **Image Source**, then choose **Select Sensor Images** from the menu. (It is also displayed when you check the Enable Modification box in the Manage Simulated Lane Images screen.)

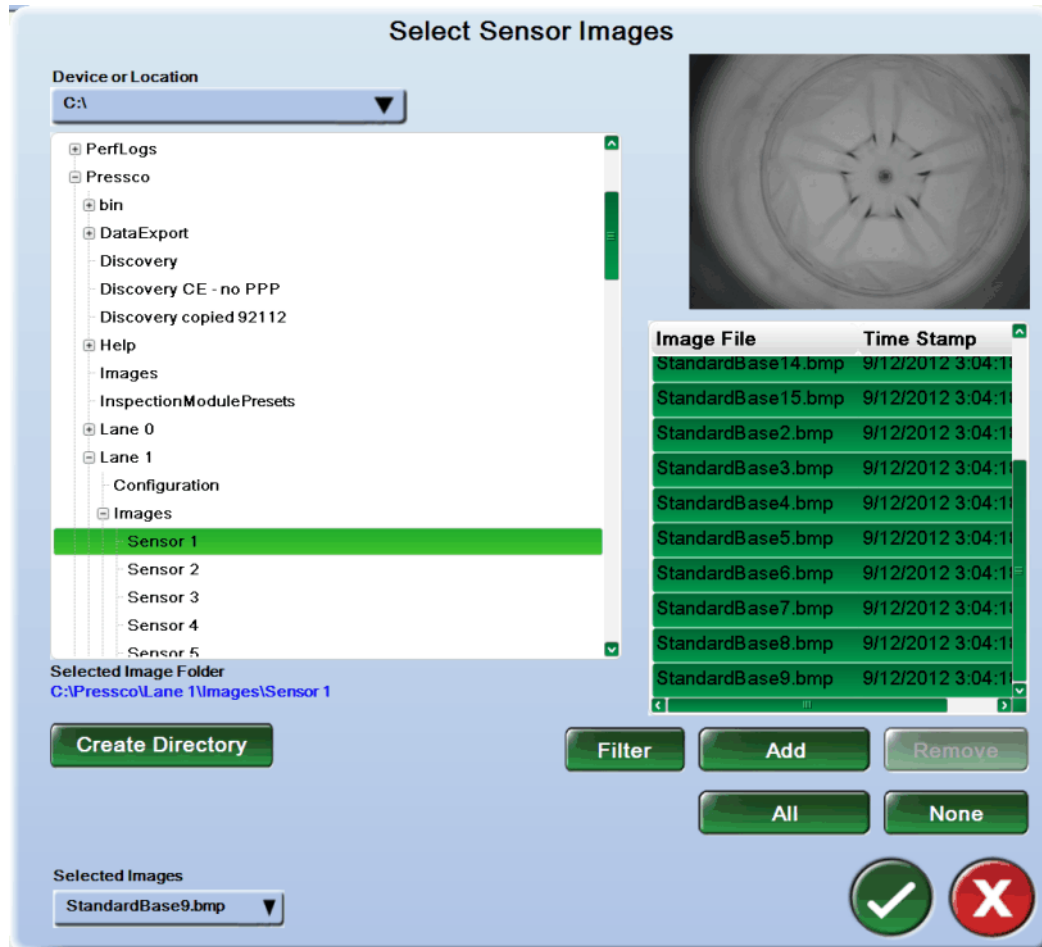

### ➤ To select images:

1. Browse through the directories using the drop-down menu at the top of the screen. The list of images in the selected directory is displayed on the right side of the screen.
2. Select an image name from the right side of the screen. Click the **All** button to select all images in the directory, or click **None** to de-select all the images.
  - To select a subset of common images, click the **Filter** button. This allows you to specify a portion of the file name.
    - A wild card (asterisk [\*]) is required in the filter name
    - An example is using "\*good\*" as a filter. Since many images are saved as either good or bad parts, this allows you to select the set of images you want.
    - Another example is using "\*.bmp" as a filter. The Intellispec system can only load bitmap (.bmp) images. If your directory has different image types, you can use the filter to select only the .bmp files.
3. The **Selected Images** drop-down menu contains the set of images you have chosen. Use the **Remove** button to remove an image from the set.

- You can add images from more than one directory. After adding selected images from one directory, browse to another directory in the left panel and add more images. The drop-down menu below **Selected Images** shows all the image files you have selected.
4. Click the OK button  to save the set of images. The next time you put the lane online, it displays the set of images you have selected.

---

## Saving Images

There are a number of ways to save an image within the Intellispec system. Through most of these options, you can save images to create a **PDL** (see "**Manage Simulated Lane Images (PDL)**" on page 146) file to load at any time, to create or troubleshoot part programs. Images can be saved whether the lane is online or offline, except the option: "Saving Images Automatically" - that option allows you to save information while the lane is online.

**Save any image:** In most parts of the system, right-click over any image to save it. A Save Image menu item will be displayed. Select the desired type of image, and save it. When the system asks you where to save it, use the disk icon to browse to a location. If you are using a USB device, insert the device and browse to it. This is useful to save images to include with a **Support Package**.

More information about how to save images from different locations can be found through the links below:

**Saving Images Through the Sensor Menu** (on page 150)

**Saving Images Automatically** (on page 151)

**Saving Images through the Retro-Spec interface** (on page 153)

**Saving Individual Images While Editing an Inspection** (on page 157)

**Saving Reject Images** (on page 158)

**Saving a Region of Interest (Unwrapped) Image** (on page 162)

## Saving Images Through the Sensor Menu

This tool allows you to quickly save a set of images from one sensor (up to 100 images). You can use these images to set up and test part programs. You can save images whether the lane is online or offline.

❖ *Note: Some menu items are only available to advanced level users.*

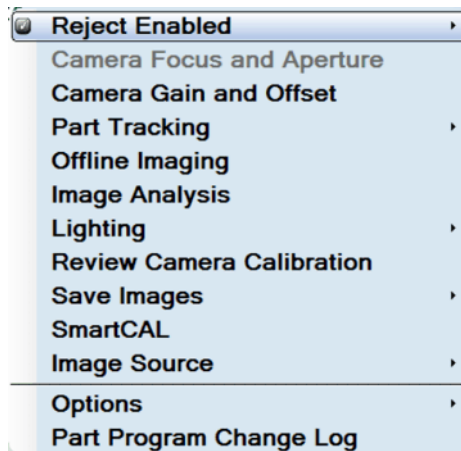

### ➤ To save images:

1. Right-click over the Sensor button in Lane Overview or Sensor Overview mode to see the Sensor menu.



- From the Sensor menu, select Save Images, then choose whether to save the last 100 images, the latest sensor defect images, or auto-save images. (See *Saving Images Automatically* (on page 151)).



- For the last 100 images or latest sensor defects, a dialog box prompts you to change directories. Click the disk button  to browse to a different folder if desired.
- Type a prefix for the set of image files, if desired. The default "Defects" prefix is provided for you.
- Click the OK button  to save the images.

#### Save Last 100 Images

Save the last 100 images captured by the current sensor.

#### Save Latest Sensor Defects

Save the latest defect images shown in the Reject Images thumbnails, up to 100 images.

## Saving Images Automatically

This feature automatically saves images from one sensor when the lane is online. You can set up this feature to save up to 1000 images, and specify which images to save. The images can be related to an inspection in the current part program, and they can be images from parts that pass, fail, or both.

#### ➤ To get to this menu:

- Right-click a sensor button. The sensor menu is displayed.

- Select Save Images > Auto-Save Images. The Image Auto-Save menu is displayed. The menu items are described below.

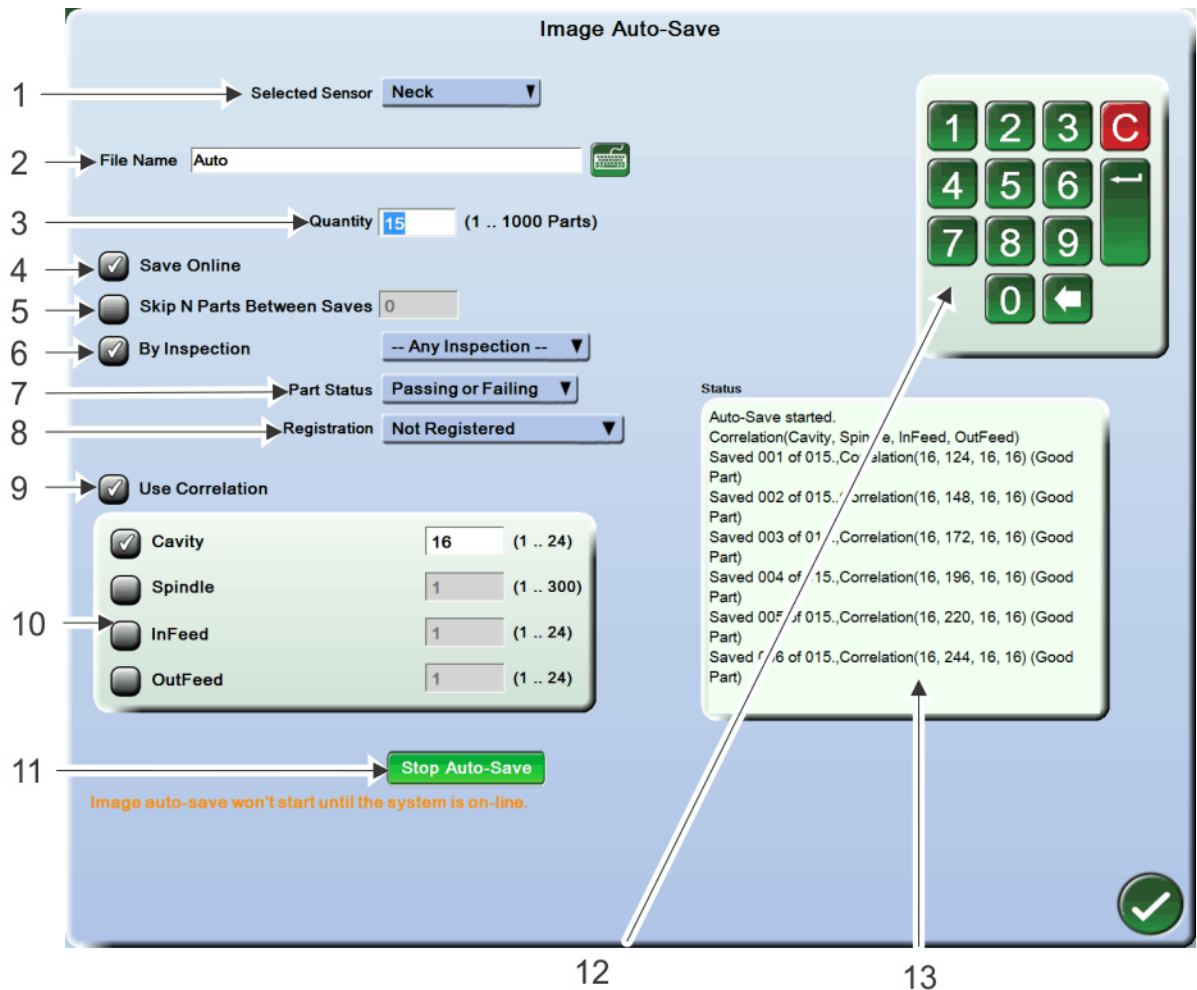

1	<b>Selected Sensor</b> - Select the sensor in the current lane from which to save images
2	<b>File Name</b> - Create a file name, preferably something descriptive of the part you are inspecting. When you click in the file name box, an on-screen keyboard is provided. The system automatically appends and increases a number in the name, and indicates whether the part passed [P] or failed [F]. An example name is "Auto0001_S1_P.bmp." This name indicates the first image saved [0001], from sensor 1 [S1] and it passed inspection [P].
3	<b>Quantity</b> - Select how many images to auto-save, between 1 and 1000. Use the numeric keypad [item 11] to enter a number.
4	<b>Save Online</b> - Check the box to enable auto-save. Images will only be saved when the lane is online.
5	<b>Skip N Parts Between Saves</b> - Check the box if you do not want to save consecutive images. Place the cursor in the number box and use the numeric keypad [item 11] to enter the number [N] of parts to skip between saved images.
6	<b>By Inspection</b> - This is only available when you have one sensor selected [in item 1]. Check the box to enable saving images related to a specific inspection. Use the drop-down menu to select the inspection from the current part program.
7	<b>Part Status</b> - Select whether to save images that pass or fail inspection, or both. When images are saved, the file name contains [P] for passing or [F] for failing.

8	<b>Registration</b> - Select whether to save images that failed registration [Not Registered], had a found center [Centered], or had a found center and orientation [Centered and Oriented].
9	<b>Use Correlation</b> - [available if the correlation option is installed] Check this box to enable saving images correlated to specific machine parts.
10	<b>Machine parts</b> - if Use Correlation is enabled, select the machine part(s) to which the saved images are correlated. Also enter a machine part number in the box provided.
11	<b>Start Auto-Save</b> - Click the <b>Start Auto-Save</b> button to begin automatically saving images. Note that images are only saved when the lane is online. To stop the automatic saving of images before the process is complete, click the button when it reads <b>Stop Auto-Save</b> . If all the specified images have been saved, the button returns to the default Start Auto-Save state.
12	<b>Numeric keypad</b> - Use the numeric keypad to enter values for quantity of images to save [item 4], or to skip a number of images between saves [item 6].
13	<b>Status</b> - This area displays the status of the auto-save process.

## Saving Images through the Retro-Spec interface

This topic covers how to save images through the Retro-Spec interface. You may want to save images to reference later, to send to Pressco for troubleshooting help, or to set up a part program. Saving images is done through the Retro-Spec interface from Registrations, Orientations, or Analyses. You must first have at least a temporary **Part Program** (see "**How to Create, Copy, or Import a Part Program**" on page 168) loaded. You must have user permissions to edit part programs.

Images can be saved whether the lane is online or offline. Images are saved as grayscale bitmap images, at 302 KB in size. No graphics are saved with the images.

### ➤ To save one or more images:

1. Go to Sensor Overview mode [from Home, click Lane button, then Sensor button].
2. Put the lane online for a while to acquire several part images.
3. Take the lane offline to stop acquiring images (if desired).
4. Double-click the name of any Registration, Orientation, or Analysis in the inspection tree to view the Retro-Spec interface. Note: you cannot save images through a Region of Interest (ROI).
5. Right-click the Retro-Spec graph to see the **Retro-Spec options** (on page 187) menu.

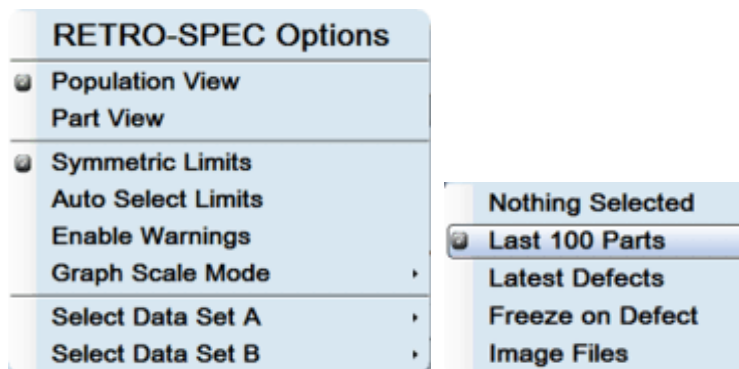

6. Select an option for Data Set A and/or Data Set B (from **Select Data Set A** and **Select Data Set B**). The Retro-Spec graph is updated with the selected part data.

7. In the Retro-Spec graph, click the bar corresponding to the image you want to save.

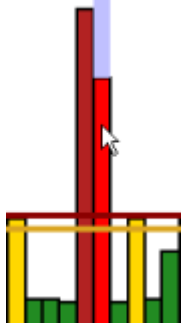

❖ *Note: You can save a whole data set from the Save Image Files menu.*

8. Click the disk icon  on the Retro-Spec graph. The Save Image Files menu is displayed.

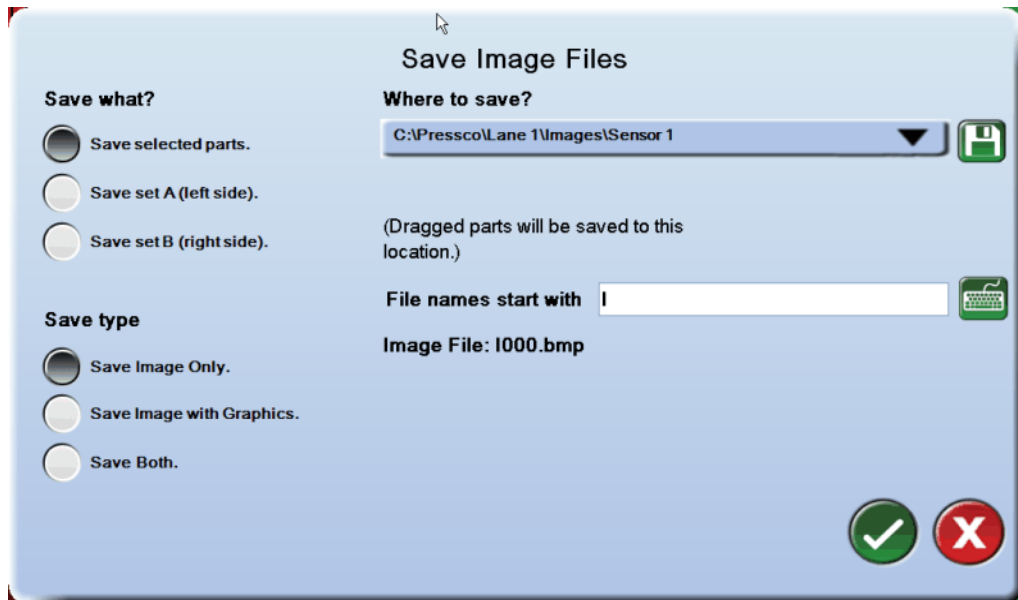

9. Choose which images to save under the "Save What?" column. Save only the selected part image, or all the images from Data Set A or Data Set B.
10. Choose the type of image to save under the "Save Type" column. Save the image only, the image with the graphics overlaid, or two separate images (both).
11. To name the image files, enter a prefix in the "File names start with" box. The default prefix is "I" for "image." This step is important if you already have saved images and you do not wish to overwrite them.

12. Use the disk icon  under "Where to Save?" to browse to the location where you want to save images. Use the **Select Location** menu to save images to the Intellispec hard drive or to a USB device. Create a new directory, if desired, for your images.

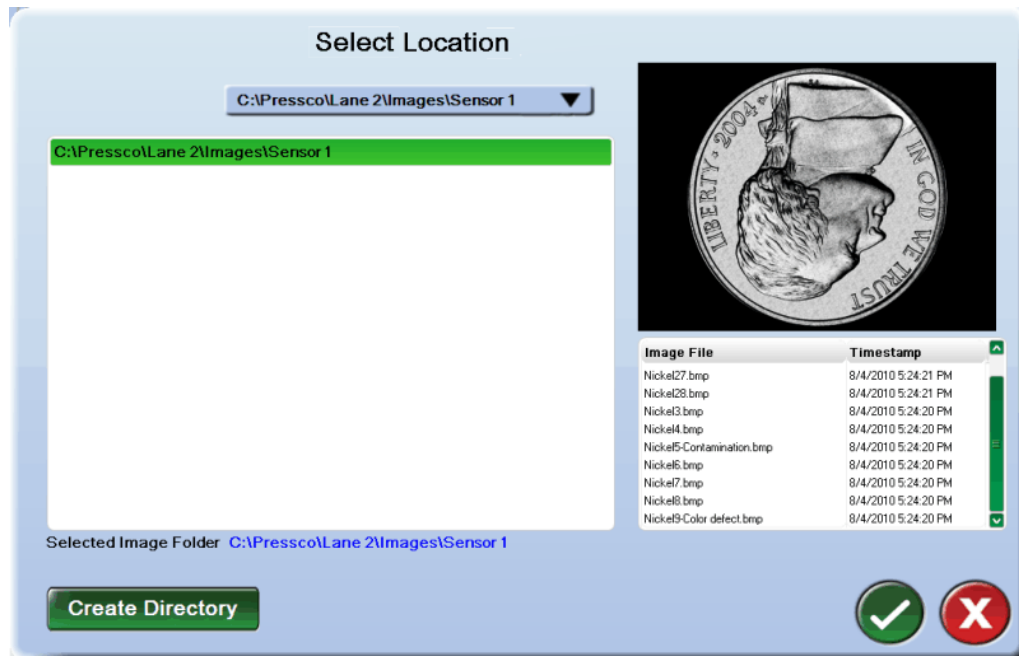



13. Click the OK button  twice to save the image(s). The images are saved.

❖ *Note: all images in a data set will be named with unique file names. However, if you save another data set to the same folder at a later time using the same prefix, the original images will be overwritten. See **Recommendations for Image File Management** (on page 155).*

14. To save subsequent single images to the same location, click the bar on the Retro-Spec graph for another part, and then click the disk icon on the graph. Click the OK  button. The part image will be saved.

You can **load** (see "**Loading Saved Images**" on page 163) saved images at a later time for reference, setting up a part program, or testing.

❖ *Note: Part images can be dragged to the disk icon  and saved if the Lock/Move Parts button is unlocked:  See more information about this button in the **Retro-Spec Population View Graph** (on page 185).*

## Recommendations for Image File Management

When you save the images for data sets to a folder, each image is given a unique name. However, if you save another data set to the same folder, those original images are overwritten. Therefore we recommend that you create new folders when you save data sets. Our recommendations are:

- Make new folders and give them meaningful names
- Add the word Defects (or Good) to the folder name to indicate that you are storing defects (or good images) for that inspection

When you are **saving images** (see "**Saving Images through the Retro-Spec interface**" on page 153), you can create new folders (directories).

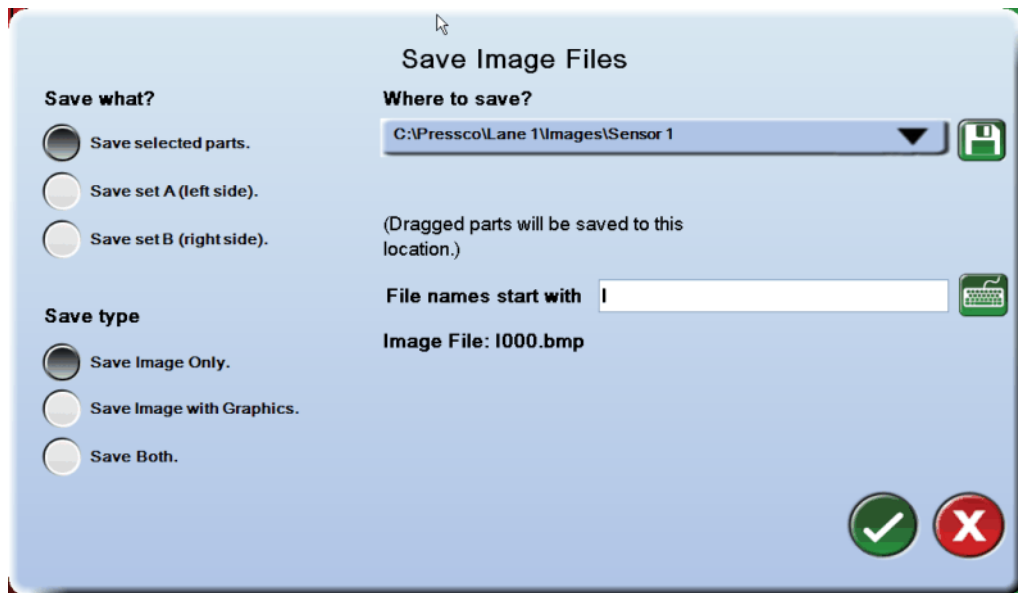

➤ **To create a new folder while saving images:**

1. Click the disk icon  on the Retro-Spec graph. The Save Image Files menu is displayed.

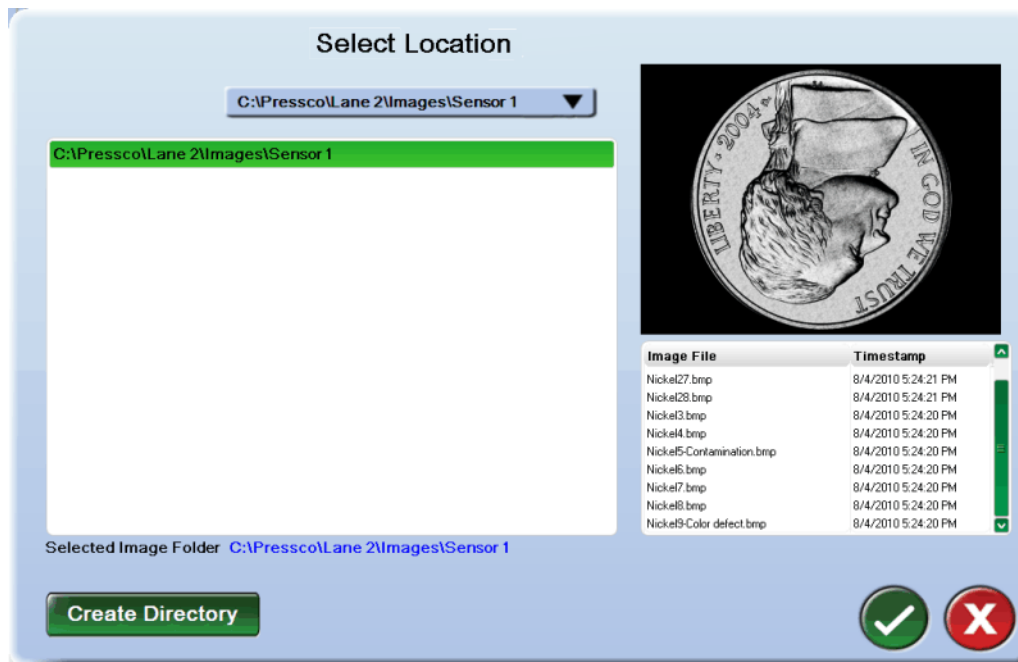

2. Click the disk icon  to browse folders. The Select Location menu is displayed.



3. Click the button at the top of the menu to browse to the location that makes sense to the sensor (example, "C:\Pressco\Lane 1\Images\Sensor 1\"). Note that you can also save images to a USB device.
4. Click the **Create Directory** button to create a new folder. Rename the folder something meaningful, such as the area of inspection (example, Countersink). If you are saving images of defects, use Defects in the folder name.
5. Click the OK  button to complete browsing and return to the Save Image Files menu.
6. Click the OK  button to save the images. Depending where the images are being stored, it may take up to a minute to complete, especially if a USB device is used.

## Saving Individual Images While Editing an Inspection

You can save one image while editing an inspection. To save the image, right-click over the image to see the Image Options menu. Select Save Image from the menu, then choose the desired option. The image can be saved whether the lane is online or offline.

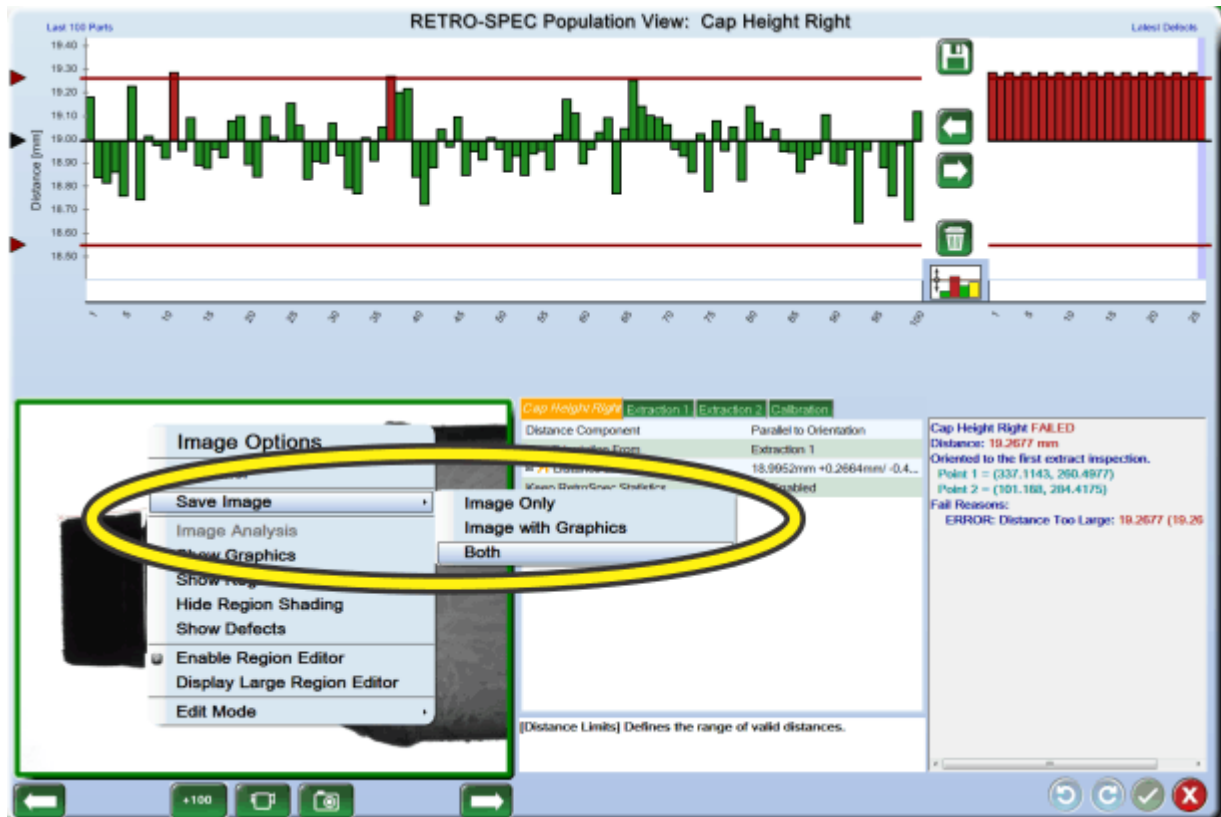

The options are shown below.

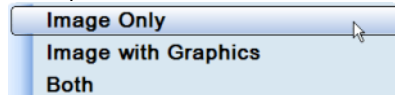

- **Image Only** - Saves a bitmap (.bmp) image with no graphics.

❖ *Note: only bitmap images can be loaded back into the Intellispec*

- **Image with Graphics** - Saves the current image with inspection graphics on the image. It is saved as a Portable Network Graphic (.png) file.
- **Both** - Saves both files - (.bmp) with no graphics, and (.png) with graphics.

When you save an image, a dialog box, as shown below, provides options for saving the image. The image is saved to the default location shown in the box, unless you click the disk icon and specify a different location. A default file name including Lane name, date, and time is provided for you. You can rename the image by clicking on the keyboard icon and typing a new name using the on screen keyboard.



## Saving Reject Images

You can save images from parts that were considered defective, either from **Lane Overview** or **Sensor Overview** mode. This can be done when the **Reject Images** button on the right side of the screen is selected. Up to 100 images can be saved at a time. These images can be loaded at a later time as simulated images to assist in programming inspections or training.

Images can be saved whether the lane is online or offline.



### ➤ To save reject images:

1. Right-click over any image displayed in the reject image area on the screen (Images in Sensor Overview mode shown below). The Defect Image Options menu is displayed.

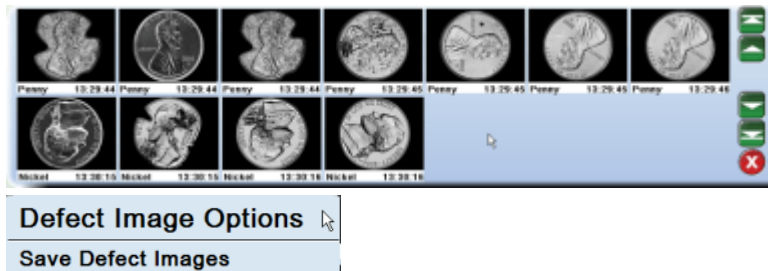

2. Select Save Defect Images from the menu. The Save Image menu allows you to change the directory or name of the images to be saved. A default name and directory are provided for you.
3. Change the directory or file name if desired and click the OK button to exit. The images are saved as bitmap (.bmp) images. Each image is given a unique name.

## Saving Reject Images by Inspection

You can save images that failed a specific inspection in **Sensor Overview** mode [from System Overview mode, select a lane, then click a Sensor button [item 1] to go to Sensor Overview mode]. There are two ways to save inspection-specific images. Refer to the illustration below.

❖ *Note: If you select an inspection that did not fail any parts, all reject images from that sensor, up to 100 images, are saved.*

➤ **If the Reject Images button [item 4] is selected on the right side of the screen:**

1. Click the name of an inspection [item 3] in the inspection tree. The images associated with that inspection are displayed in the thumbnail image area.
2. Right-click over the set of images to see the Defect Image Options menu [item 2].
3. Select Save Defect Images from the menu. The Save Image menu allows you to change the directory or name of the images to be saved. A default name and directory are provided for you.
4. Change the directory or file name if desired and click the OK button to exit. The images are saved as bitmap (.bmp) images. Each image is given a unique name.

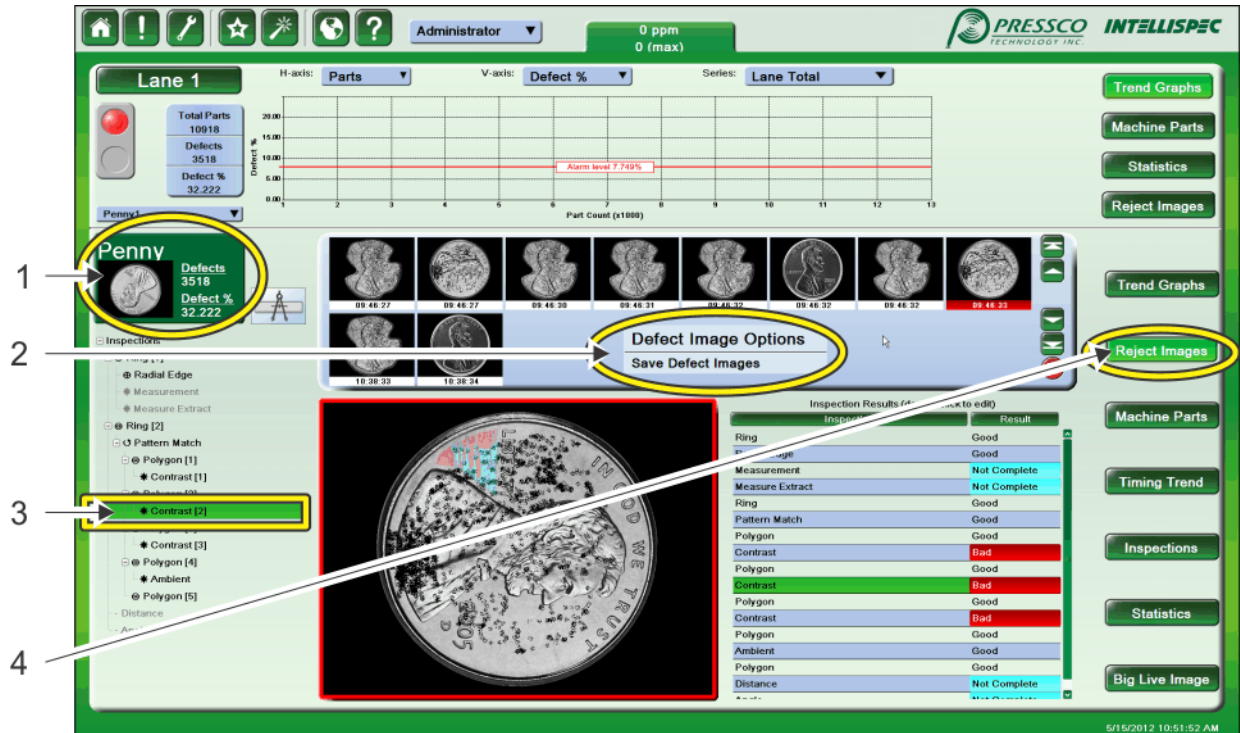

1	Sensor button
2	Right-click over image thumbnails to see Defect Image Options menu
3	Select one inspection to view defect images associated with that inspection
4	Select the Reject Images button to view thumbnails of images from defective parts

➤ **If the Statistics button [item 4a] is selected on the right side of the screen (refer to the illustration below):**

1. Click the name of an inspection [item 3a] in the inspection table. The images associated with that inspection are displayed in the thumbnail image area.
2. Right-click over the set of images to see the Defect Image Options menu [item 2].
3. Select Save Defect Images from the menu. The Save Image menu allows you to change the directory or name of the images to be saved. A default name and directory are provided for you.
4. Change the directory or file name if desired and click the OK button to exit. The images are saved as bitmap (.bmp) images. Each image is given a unique name.

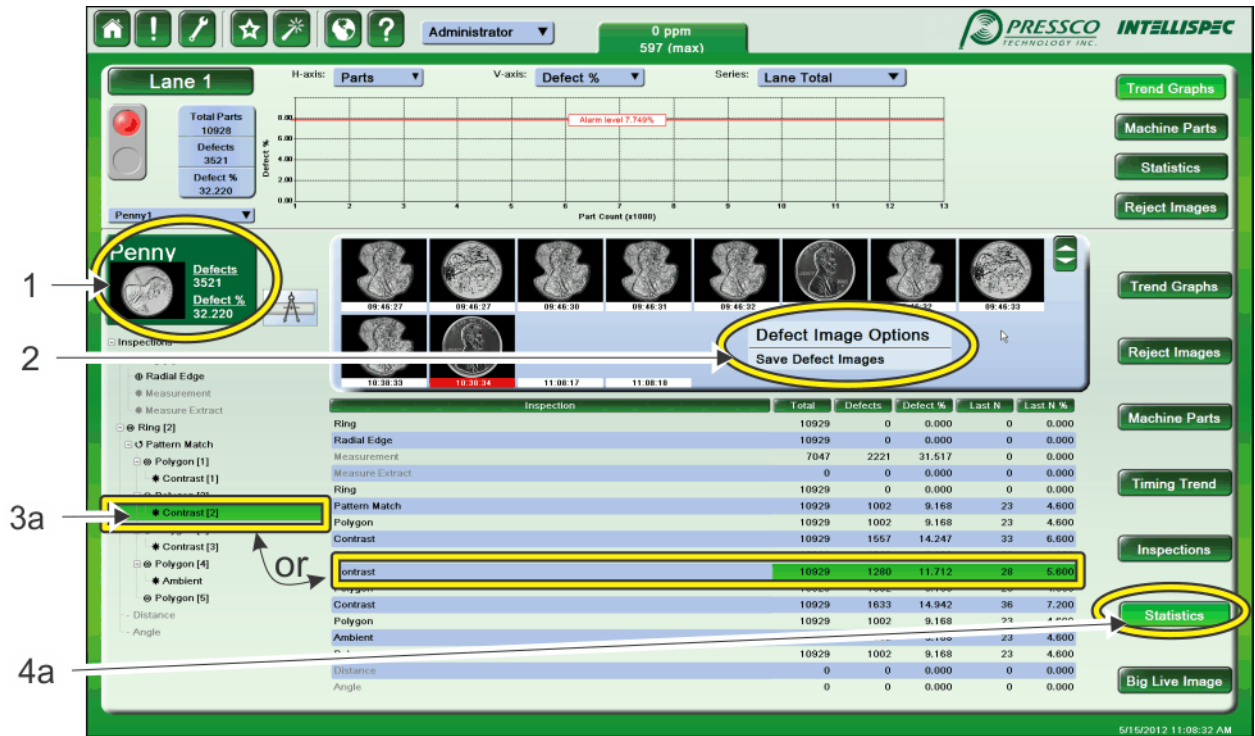

1	Sensor button
2	Right-click over image thumbnails to see Defect Image Options menu
3a	Select one inspection to view defect images associated with that inspection
4a	Select the Statistics button to view detailed inspection statistics

## Saving Reject Images by Machine Part

You can save images that failed inspection and are associated with specific machine parts.

### ➤ To save images associated with a machine part (refer to the illustration below):

1. Go to Sensor Overview mode: from System Overview mode, select a lane, then click a **Sensor** button [item 1] to go to Sensor Overview mode.
2. Click the **Machine Parts** button [item 4b] on the right side of the screen. The images associated with machine parts are displayed in the thumbnail area.
3. Select a different machine part from the drop-down menu [item 3b], if desired.
4. Select a specific machine part from the graph [item 5]. The name of the machine part is displayed in the button above the V-axis selection.
5. Right-click over the set of images to see the Defect Image Options menu [item 2].
6. Select Save Defect Images from the menu. The Save Image menu allows you to change the directory or name of the images to be saved. A default name and directory are provided for you.
7. Change the directory or file name if desired and click the OK button to exit. The images associated with that machine part are saved as bitmap (.bmp) images. Each image is given a unique name.

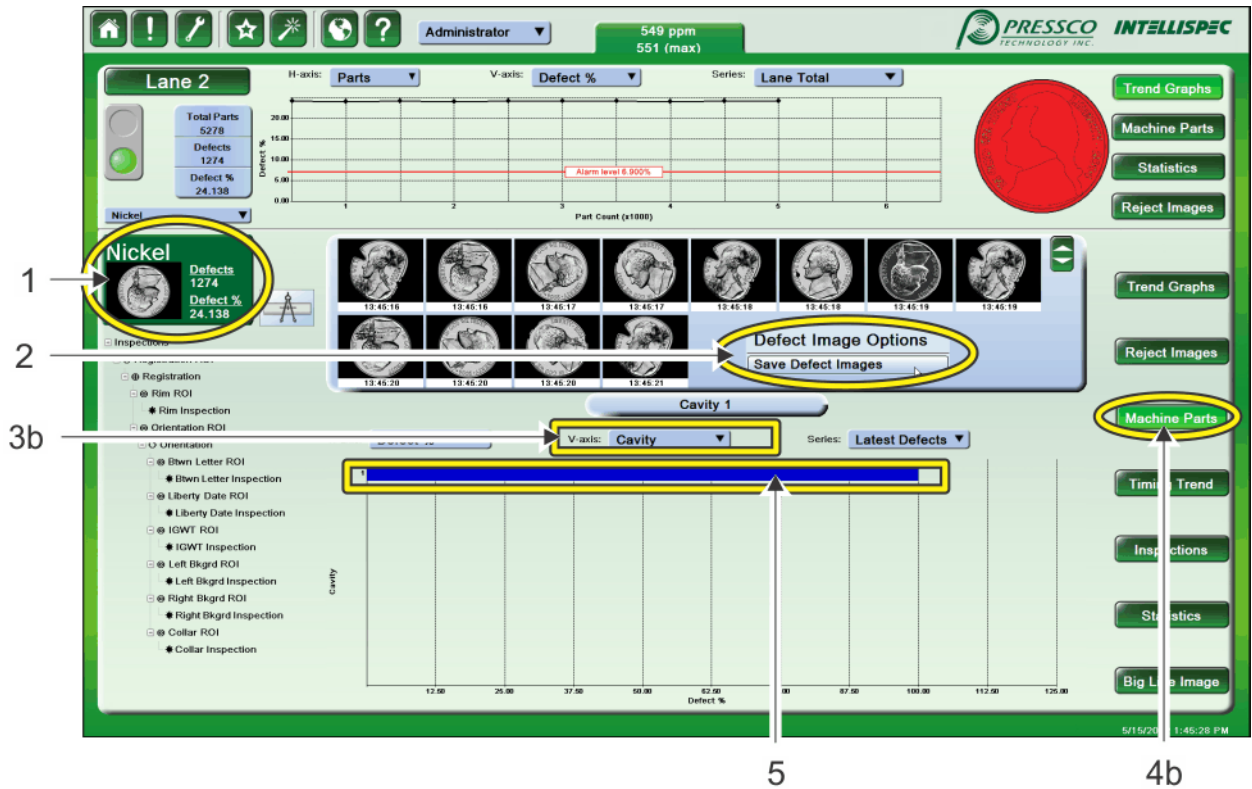

1	Sensor button
2	Right-click over image thumbnails to see Defect Image Options 1 menu
3b	Select a machine part type
4b	Select the Machine Parts button to view thumbnails of defective parts associated with specific machine parts
5	Select a specific machine part from the graph

## ***Saving Individual Reject Images***

You can select any thumbnail image in **Sensor Overview** mode and save it.

### ***➤ To save an image (refer to the illustration below):***

1. Go to Sensor Overview mode: from System Overview mode, select a lane, then click a **Sensor** button [item 1] to go to Sensor Overview mode.
2. Click any thumbnail image [item 3c] (available when Reject Images or Statistics button is selected). The Reject Images button becomes selected after you select the thumbnail image.
3. Right-click over the large image at the bottom of the screen to see the Image Options menu [item 2c].
4. Select Save Image from the menu. Choose to save the Image Only, Image with Graphics, or Both. For information about these options, refer to ***Saving Individual Images While Editing an Inspection*** (on page 157). The image is saved.

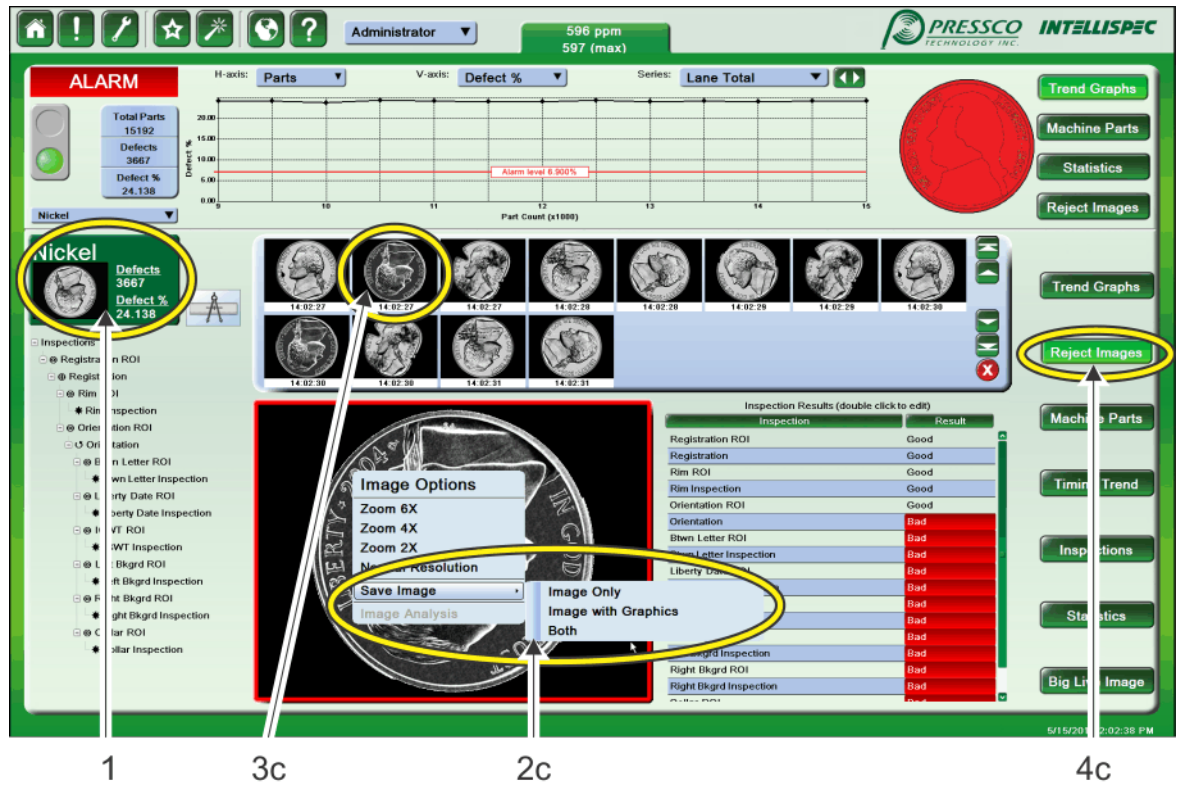

1	Sensor button
2c	Right-click over the image to see Image Options menu
3c	Select a thumbnail image
4c	When you select a thumbnail image, the Reject Images button becomes selected for you

## Saving a Region of Interest (Unwrapped) Image

You can save the unwrapped region display while you are editing an inspection. The image will be saved as a Portable Network Graphic (.png) file. An example unwrapped image is shown below. The image will be the same dimensions as the defined region of interest. Note that the Intellispec stretches some images to fit the region of interest window.

The image can be saved whether the lane is online or offline.



❖ *Note: whether regions, edges, or other graphics are saved depends on the settings when you save the image. If diagnostics are on, or if Show Graphics is enabled, those items are saved with the image.*

### ➤ To save the unwrapped image while editing an inspection:

1. Right-click in the unwrapped image area to view the ROI Options menu.

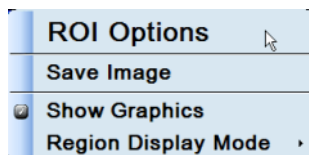

2. Choose Save Image from the menu. The Save Image menu allows you to change the directory or name of the image to be saved.
3. Change the directory or file name as desired and click the OK button to exit. The image is saved as a .png file.

## Loading Saved Images

This topic covers how to load images through the Retro-Spec interface. You can also choose an **Image Source** (on page 145) through the Sensor menu.

You can load images previously **saved** (see "**Saving Images through the Retro-Spec interface**" on page 153) on the Intellispec to use as reference, test part sets, or to set up a part program without the production line running. You must have user access to edit part programs.

### ➤ To load images:

1. Go to Sensor Overview mode [from Home, click Lane button, then Sensor button].
2. Double-click the name of any Registration, Orientation, or Analysis in the inspection tree to view the Retro-Spec interface graph. A partial graph is shown below.

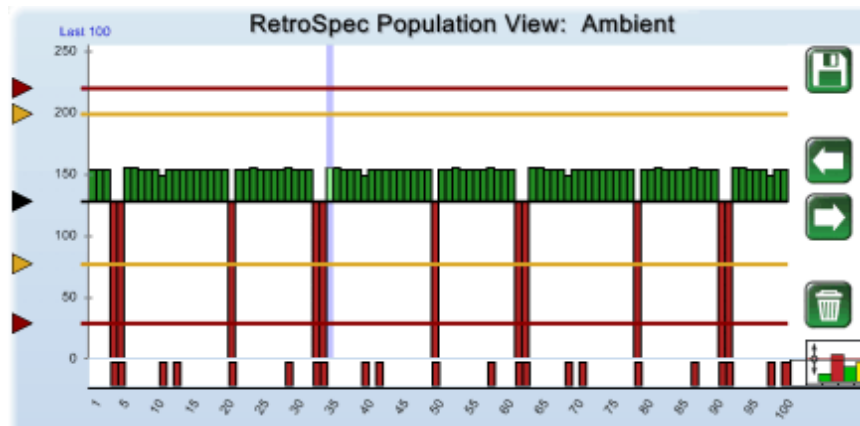

3. Click one of the left or right arrow buttons  to view the **Select Data Sets** menu.

4. Click the Image Files button for either Set A or Set B.

- Click the disk icon  to browse to the folder where the images were saved. The **Select Location** menu is displayed.

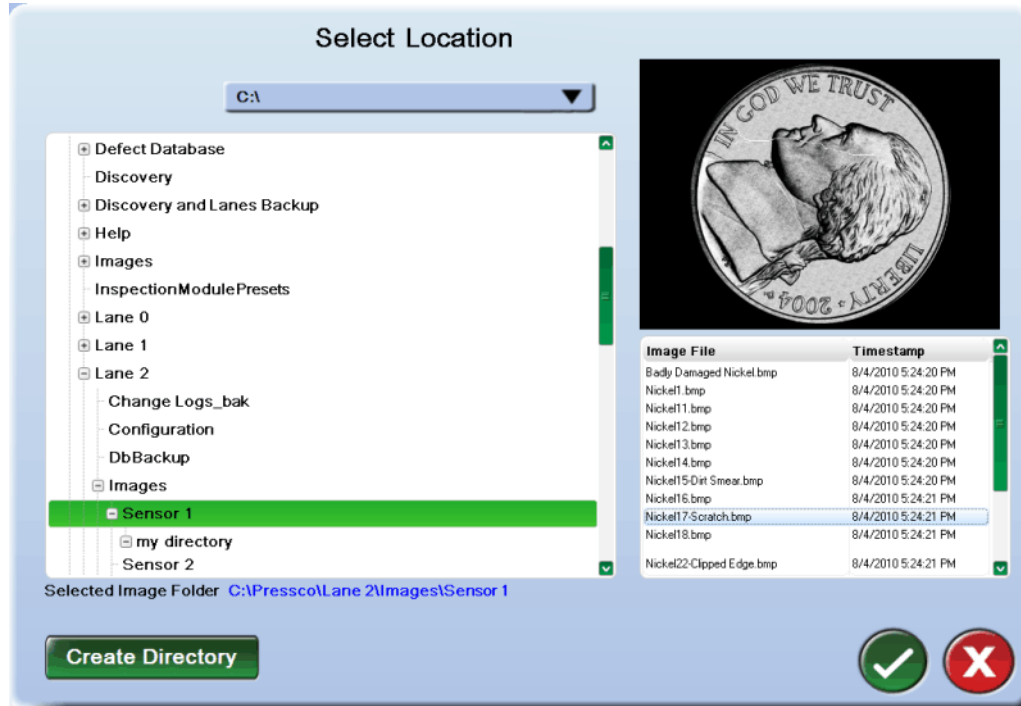

- Browse to and select the folder that contains the images you want to load.
  - To preview the images in the folder, browse through the file names in the window on the right of the Select Location menu.
- Click the OK button  twice. The Intellispec loads all the bitmap images that were previously saved in the selected folder.

---

# Image Options

While viewing an inspection screen, right-click in the part image to see the Image Options menu. A small check indicates that the option is currently active. Click an option to make it active or toggle it to inactive. The default Image Options menu is shown below.

❖ *Note: some menu items are not shown when you are viewing a registration or orientation.*

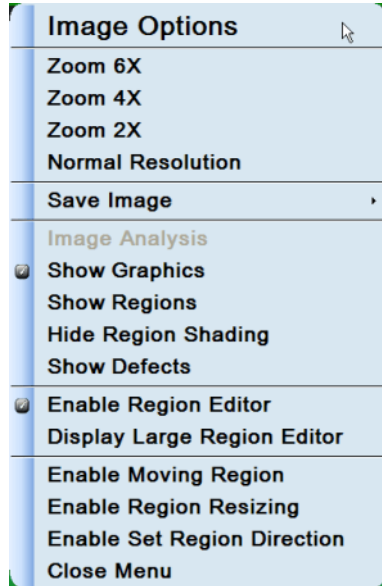

There are options for certain regions. Options are grayed out if they do not apply to the current inspection.

## Zoom - 6X, 4X, 2X

Magnify the image by the specified amount.

## Normal Resolution

Return the image to normal size.

## Save Image

Save an individual image. Refer to *Saving Individual Images While Editing an Inspection* (on page 157).

## Image Analysis

Not available from this menu as of this printing.

*Image Analysis* (on page 138)

## Show Graphics

Display the region and graphics for the current inspection.

## Show Regions

Display the region(s) from other inspections in the same part program.

## Hide Region Shading

Remove the shaded graphics from the screen so that you can see more of the part image.

## Show Defects

Not available from this menu as of this printing.

## Enable Region Editor

Change the shape and placement of the region directly on the image.

### Display Large Region Editor

Display a large part image on which you can change the shape and placement of the region. Check Enable Region Editor to make the changes to the region. Un-check this option to return the image to normal size.

### Enable Moving Center

[Available when you are editing a region] Change the center of the region when you are using Region Editor directly on the image.

### Enable Region Resizing

Resize the region directly on the image.

### Enable Set Region Direction

[Available in certain inspections such as Measure ROI] When this feature is enabled, click on the region in the image. The region box will be displayed in yellow with diamonds around the box. Click on one of the diamonds to make the inspection search in the direction of the selected diamond. The selected diamond is filled in solid yellow.

### Center Ring

[Available when you are using Region Editor directly on the image and Enable Moving Center is checked.] Click Center Ring to re-center the region on the image using the current parameters. This is a command; there will be no check mark next to this option.

### Edit Mode

A Polygon inspection has the option to “Complete Build Mode” to add points to the polygon. Edit Mode becomes available after a Build Mode is complete. Options below are only active if a check mark appears next to the option in the menu.

**Delete** - Click all polygon points that you want to delete. To stop deleting points, right-click to see Image Options menu. Select Edit Mode > and un-check Delete.

**Add** - Click anywhere between two points to add another point. To stop adding points, right-click to see Image Options menu. Select Edit Mode > and un-check Add.

**Move** - move one point in the polygon. Move the cursor over the point you want to move, then click and drag the point.

**Enable Moving Region** - [only available when Move is enabled] Move the entire region at once. To move the polygon, click anywhere on the image except on one of the yellow polygon points. Click and drag the polygon to move it.

**Enable Rotate Around Center** - [only available when Move is enabled] Rotate the entire polygon with respect to the center. To rotate the polygon, click anywhere on the image except on one of the yellow polygon points. Click and drag the polygon to rotate it.

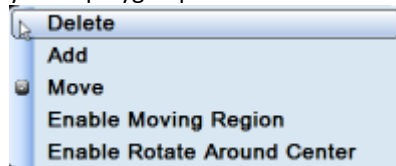

# Chapter 12

## Inspection Overview

This section includes basic information about part programs, part tracking, and Retro-Spec graphs. For detailed information about adding or adjusting inspections, see the section about **Inspections** (on page 191).

### Inspection Terminology

The following terms are used throughout this manual and the software. A basic understanding of this terminology will help you understand how the system operates.

Term	Description
<b>Analyses</b> (on page 251)	An analysis usually analyzes the pixel shade information within a region and compares it to programmed reference values. The inspection passes or fails based on these comparisons. There are also several analyses that make measurements. You may have many analyses for each inspection region.
<b>Dimensions</b> (on page 286)	The dimension inspection type is special in that it connects the results of two other inspections to do the analysis. For example, a distance inspection can connect two registrations to measure the distance between centers of two features.
<b>Enhancements</b> (on page 203)	Enhancements are used to alter images for the purpose of better defect detection, or for making certain features stand out.
Inspection Module	The housing, camera, cables, and associated electronics that are installed on or over the production line to acquire an image of your products. Sometimes referred to as a tunnel. The inspection module can consist of a different sensor than a camera to make measurements of your product.
Lane	A lane usually refers to one production line, and can contain multiple sensors.
<b>Orientations</b> (on page 243)	An orientation compensates for part rotation by finding a grayscale pattern. An analysis which must rotate with the part must follow an orientation.
Part Program	The list of regions, analyses, registrations, etc. programmed specifically for your part to detect defects or make measurements.
<b>Part Tracking</b> (on page 168)	Part Tracking refers to the monitoring of parts from the part detect sensor to reject station. This ensures that the correct parts are rejected at the correct time, and that good parts remain in the part stream.
Region	The Region indicates where on the part the analyses will take place. You may have as many analyses, enhancements, registrations, or orientations as you like in one region.
<b>Registrations</b> (on page 215)	A registration compensates for part movement by calculating the reference point on the part. All analyses follow a registration.
Reject	A part that failed one or more inspections from any sensor. The part can be physically rejected, or simply counted in the statistics.
Retro-Spec	The graphical interface used in inspections that allows you to make quick changes to a part program. It also allows you to experiment with different parameter settings to see how changes would have affected the most recent inspection population, without unnecessarily rejecting parts.

Sensor	A camera, Intellimass, or other sensor that acquires images, measurements, or other data from your product.
--------	---

## Sequence of Events During Inspection

The following illustration demonstrates a typical inspection sequence of events. Note that your system configuration may involve more components, and may be different than pictured here.

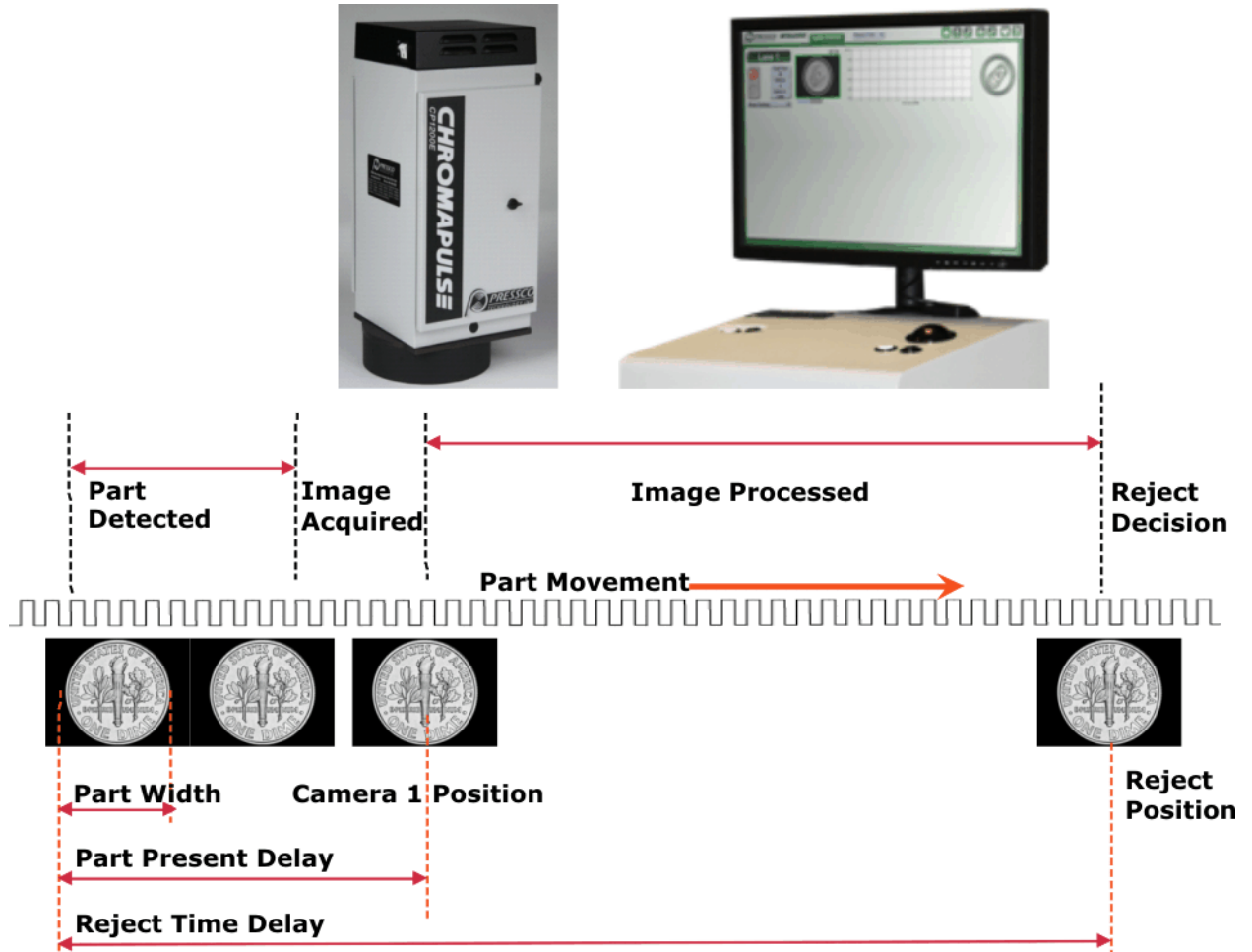

## Part Tracking

Part Tracking refers to the monitoring of parts from the part detect sensor to reject station. This ensures that the correct parts are rejected at the correct time, and that good parts remain in the part stream.

Part Tracking includes:

**Part Present Delay Calibration** (on page 110)

**Part Present Delay with Encoder** (on page 112)

**Reject Delay Calibration** (on page 113)

**Reject Confirm Calibration** (see "**Reject Confirm Calibration (Optional)**" on page 120)

**Part Width Calibration** (on page 92)

# How to Create, Copy, or Import a Part Program

A new Part Program can be created from scratch, imported or exported to/from disk, or copied from an existing part program. A Part Program is created in the Lane Overview or Sensor Overview screen.

➤ **You will need:**

- User access to create part programs

➤ **To create a Part Program:**

1. Go to a Lane Overview or Sensor Overview screen [from Home: Lane button > Sensor button].
2. Right-click over the part program drop-down menu. The Manage Part Programs menu is displayed. Choose from the available options described below.

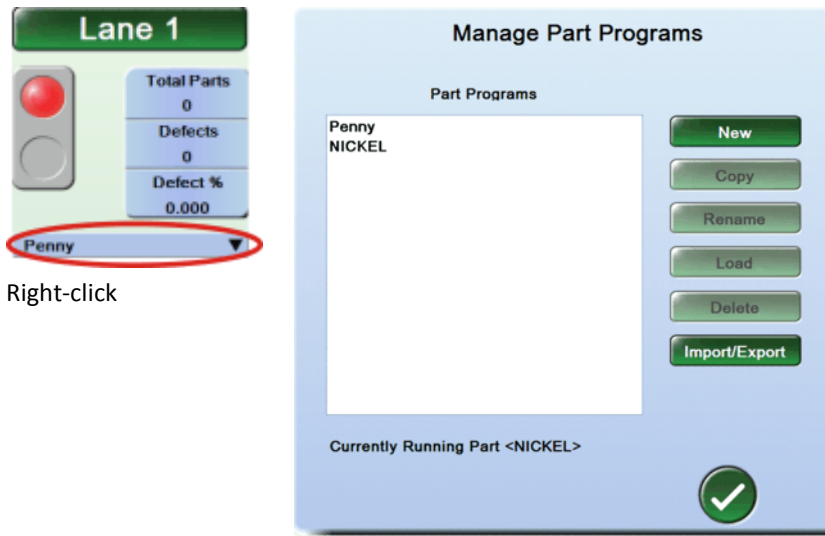

➤ **To create a new program:**

1. Click the **New** button. An on-screen keyboard is presented.
2. Name the new part program. We recommend that you use your part's name and size in the part program name.
3. Click the OK button  to save the new part program. The new part program is automatically loaded and displayed in the drop-down menu below the traffic light. No inspections are created yet.
4. Click the OK button again to close the Manage Part Programs menu.
5. Add inspections as appropriate for your part. Use inspections recommended by Pressco technicians to best inspect your part.

➤ **To copy a program:**

You can use a copy of a part program to modify it to inspect a slightly different part, or modify the copied part program without changing the original program.

1. Right-click over the part program drop-down menu (under the traffic light). The Manage Part Programs menu is displayed
2. Select one of the available part programs, then click the **Copy** button. A copy of that part program is saved under a default name such as "(1) Penny."
3. Select the new part program, and use the **Rename** button to rename the program to something more meaningful to you.

➤ **To import an existing program:**

You may have used a part program in another Intellispec system, or Pressco may have sent you a part program to use. Import that program to use it on your current system.

1. Right-click over the part program drop-down menu (under the traffic light). The Manage Part Programs menu is displayed
2. Click the Import/Export button. An "Import or Export Part Programs" menu allows you to choose a part program from disk.



3. To browse to another location on the computer, click the disk icon .
4. Locate the desired folder and click OK in the menu. The Intellispec will only choose part program names with a ".PPP" extension. You will not be able to see the names nor extensions when choosing through this menu.
  - In this example, we clicked the Part Programs folder, then clicked OK to view the available part programs.

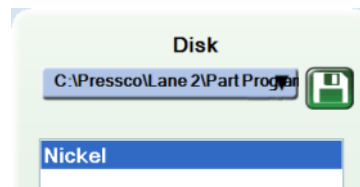
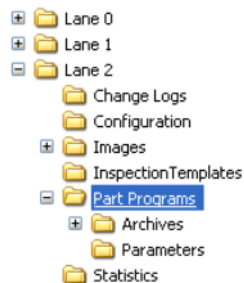

5. To import the part program, highlight the name in the right side of the menu under "Disk."
6. Click the left arrow. The part program is imported into the "Current Part Programs" list.
7. Click the OK button to exit the menu.

➤ **To load the new program:**

1. Highlight the program name in the Manage Part Programs menu, then click the **Load** button. The program name will appear in the Part Program drop-down menu on the Lane Overview or Sensor Overview screen.
2. Click the OK button  to exit the Manage Part Programs menu.

See also **Export a part program** (on page 100)

# Part Changeover

When you change your production line from one part type to another, you can quickly change the part program.

❖ *Note: Some menu items are only available to advanced level users.*

➤ **What you need:**

- User permission to Switch Part Program

➤ **To change parts:**

1. **Log in** (see "**Logging in and logging out**" on page 47).
2. Click the part drop-down menu.

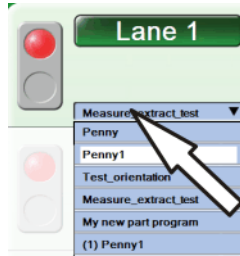

3. Click the name of the new part to inspect. The new part program is loaded on the Intellispec.
4. Put the lane online to begin inspecting new parts.

Lane-specific information is contained in each Part Program. Everything you set up have previously set up is stored: camera information, lighting information, calibration information, regions, enhancements, and analyses.

Lane Specific Information	Definition
Cameras (or other sensor)	All information for each camera or other sensor is contained in the Part Program.
Lighting	Each camera has different lighting settings for each part. When you load your Part Program after a Part Changeover, the lighting will be specific for that part and save any changes you make.
Calibration	Calibration setup for Part Present Delay and Reject Delay is saved for each part you will run. Part Present and Reject Delay will only need to be set up once.
Regions, Registrations, Orientations, Enhancements, Analyses, Dimensions, and Correlations	All Inspections will be contained in your Part Program. Also, parameter changes are saved for each Part Program.

# Inspection menu

The Inspection menu is used to create and edit part programs. Right-click over any analysis, region, orientation, or registration name to see the Inspection menu. A menu similar to the one shown below is displayed.

- ❖ *Note: For simplicity, we use the term 'inspection' to include analyses, regions, enhancements, registrations, etc.*
- ❖ *Note: some items may be grayed out if you do not have user access to those items, or if they do not apply to the current menu.*

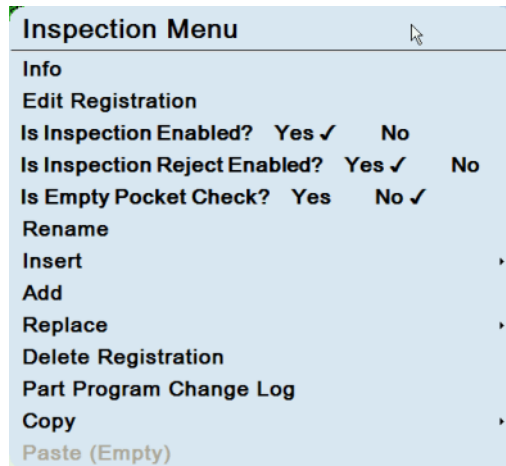

The items in the Inspection menu are as follows:

## Info

Display general information about the inspection.



1	Name - the name you have given the inspection
2	General type - Analysis, Region, Orientation, etc.
3	Specific type - sub-category (example, Ring, Polygon, or Measurement Region)

## Edit Analysis/ Region/ Orientation/ Registration

Open the Inspection Editor - performs the same action as double clicking.

For the items below, the name of the inspection becomes color-coded. See the illustration below.

## Is Inspection Enabled?

You can temporarily turn off the inspection by clicking this option. If "Yes" is checked, then inspection is enabled.

Click the menu item to disable the inspection; "No" becomes checked in the menu. If an inspection is disabled, all of its dependent inspections will be disabled as well. The inspection name is grayed out in the inspection tree when it is disabled [item d in the illustration below].

### Is Inspection Reject Enabled?

You can temporarily pass all parts regardless of whether they pass or fail the current inspection (if Reject is disabled). If "Yes" is checked, then inspection reject is enabled.

Click the menu item to disable the inspection reject; "No" becomes checked in the menu. The inspection name is displayed in red when the inspection reject is disabled [item c in the illustration below].

### Is Empty Pocket (on page 191) Check?

Is the current inspection used as an Empty Pocket check? If "Yes" is checked, then inspection is being used as an empty pocket check.

When the Empty Pocket Check is enabled, the inspection is highlighted in blue in the menu as shown below [item b].

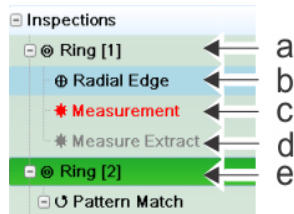

a	Inspection in normal state
b	Inspection is an empty pocket check
c	Inspection reject is disabled
d	Inspection is disabled
e	Inspection is currently selected by the cursor

### Rename

Rename the inspection to something that makes sense to you. This name will appear in the inspection tree, graphs, and anywhere else the inspection name occurs.

### Insert

Choose from the available list to add one item above the currently selected item.

### Add

Add an item from the available list. The list varies, depending on the current item.

### Replace

Replace the current item with a similar item. Regions can be replaced with other regions, registrations replaced with other registrations, etc.

### Delete Analysis/ Region/ Orientation/ Registration

Delete the current item from the inspection tree list. If the item has other items below it (at a lower hierarchy), those items are deleted as well.

### Delete All Inspections

[only shown when you right-click on "Inspections" at the top of the inspection tree] Delete all inspections from the current part program.

### Part Program Change Log (on page 174)

Display the Part Program Change Log. This lists the inspections and the edit history for each. You can view all inspections from one sensor, other sensors, or other part programs.

### Copy

Copy the current item and descendants (if applicable). The items are copied to the clipboard. Use Paste to place them in the inspection list. You may copy a part program to the same sensor, a different sensor, or different lane.

To copy the part program to another Intellispec system, use the Export function. See **Export a part program** (on page 100).

**Paste**

Paste the contents of the clipboard into the inspection list. The contents are pasted below the currently selected item.

**Collapse All**

[only shown when you right-click on "Inspections" at the top of the inspection tree] Collapse the inspection tree to the top level inspection. This does not affect inspection.

## Part Program Change Log

The part program change log lists the inspections and the edit history for each. You can view all inspections from one sensor, other sensors, or other part programs. This is helpful if you want to see the previous settings for an inspection.

Type	Time Stamp	User	Camera/Sensor	Inspection	Parameter	Before	After
Create	2011-02-15 18:12:07	Administrator					
Create	2011-02-15 18:12:19	Administrator	Nickel	Ring			
Edit	2011-02-15 18:12:49	Administrator	Nickel	Ring	Inner Radius	25	189
Edit	2011-02-15 18:12:49	Administrator	Nickel	Ring	Thickness	50	53
Create	2011-02-15 18:12:57	Administrator	Nickel	Radial Edge			
Edit	2011-02-15 18:13:36	Administrator	Nickel	Radial Edge	Target Size	100	230
Edit	2011-02-15 18:13:36	Administrator	Nickel	Radial Edge	Qualifying Percent Limits	E:25.0 W:50.0 G:	E:32.71 W:47.31 G:
Create	2011-02-15 18:13:56	Administrator	Nickel	Measurement			
Edit	2011-02-15 17:17:21	Administrator	Nickel	Measurement	Feature Type	Light Feature	Borders: Both Light
Edit	2011-02-15 17:17:21	Administrator	Nickel	Measurement	Inner Diameter Enabled	No	Yes
Edit	2011-02-15 17:17:21	Administrator	Nickel	Measurement	Width Enabled	No	Yes
Edit	2011-02-15 17:17:21	Administrator	Nickel	Measurement	Width Units	pixel	Custom unit
Edit	2011-02-15 17:17:21	Administrator	Nickel	Measurement	Width Nominal Value	53.0	26.5
Edit	2011-02-15 17:17:21	Administrator	Nickel	Measurement	Width Min/Max	E:-50.0 W W:-10.0 G:[55555.0] G:0.0 W W:0.0 E	E:-25.42 W W:-25.17 G:[26.5] G:0.0 W W:0.77 E
Edit	2011-02-15 17:17:21	Administrator	Nickel	Measurement	Width Average	E:-50.0 W W:-10.0 G:[55555.0] G:0.0 W W:0.0 E	E:-28.5 W W:-26.5 G:[26.5] G:0.0 W W:0.0 E
Edit	2011-02-15 17:17:21	Administrator	Nickel	Measurement	Width Continuity	E:-50.0 W W:-10.0 G:10.0 W W:50.0 E	E:-40.76 W W:-8.65 G:3.63 W W:4.82 E
Edit	2011-02-15 17:17:21	Administrator	Nickel	Measurement	Width Range	G:53.0 E	G:11.65 E
Create	2011-03-01 18:03:37	Administrator	Nickel	Clipping			
Edit	2011-03-01 18:05:17	Administrator	Nickel	Clipping	Use Clipping	No	Yes
Create	2011-03-01 18:05:28	Administrator	Nickel	Stretch Grayshades			

➤ **To view the part change log:**



1. Click a sensor button to go to Sensor Overview mode.
2. Right-click over a sensor button or inspection name and select **Part Program Change Log** from the Inspection menu. If you right-clicked over an inspection name, and the current inspection has never been changed since it was set up, no data is displayed.
3. Click any of the available check boxes to view other inspections, inspections from other part programs, or inspections from other sensors. Some boxes are dependent on others; for example, you must click a dark gray check box before a light gray check box becomes active.

To view a full column width, click and drag the column title to re-size that column.

Type	Time Stamp	User	Part Program	Inspection
Create	2010-08-20 08:26:29	Tncia	Penny1	

Click the **Details** button to see more information about the highlighted item. A pop-up window displays more information, including the number of times the inspection was modified.

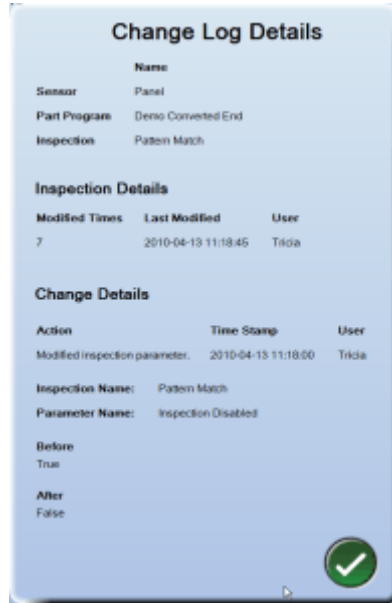

Click the **Filter** button to choose the items to display in the log. As soon as you select any option, the Change Log is updated. Some options are dependent on others; for example, if you want to see the Historic Names for the Sensor, you must choose Historic Names for Inspection first.



➤ **To see inspection differences:**

1. Click the **Difference** button to see a list of differences in inspections. A Mark Start/ Mark Stop menu is displayed, and the inspections in the list are highlighted in magenta (depending where your cursor is).



Type	Time Stamp	User	Camera/Server
Create	2010-04-16 10:43:19	Tricia	Rivet
Create	2010-04-16 10:43:21	Tricia	Rivet
Create	2010-04-16 10:48:38	Tricia	Rivet
Create	2010-04-28 15:37:48	Tricia	Panel
Edit	2010-04-28 15:38:14	Tricia	Panel
Edit	2010-04-28 15:38:51	Tricia	Panel
Edit	2010-04-28 15:38:51	Tricia	Panel
Create	2010-04-28 15:48:12	Tricia	Panel
Edit	2010-04-27 14:27:18	Tricia	Rivet
Edit	2010-04-27 14:27:24	Tricia	Rivet
Edit	2010-04-27 14:27:28	Tricia	Rivet
Edit	2010-04-27 14:27:36	Tricia	Rivet
Edit	2010-04-27 14:28:11	Tricia	Panel
Edit	2010-04-27 14:28:31	Tricia	Panel
Edit	2010-04-27 14:28:41	Tricia	Panel
Edit	2010-04-27 14:28:58	Tricia	Panel

2. Click the **Mark Start** button.
3. Click on the first item in the list where you want to begin viewing inspection differences. (this is similar to holding the Shift key and selecting multiple items in a list)
4. Click the **Mark Stop** button.
5. Click on the last item in the list where you want to view inspection differences. Your selected items are highlighted in magenta.

- Click the OK button  in the Mark Start/ Mark Stop menu. A Differences table is displayed. This allows you to view a shorter list of items, only those of which have been changed. Only edited (not created) inspections are included.

**Differences**

User	Camera/Sensor	Part Program	Inspection	Parameter	Before	After
Tricia	Panel	Demo Converted End	Clipping	Enable Clipping	True	False
Tricia	Panel	Demo Converted End	Clipping	Clipping Mode	Clip Black Level	Clip Black and White Levels
Tricia	Panel	Demo Converted End	Clipping	Black and White Level	30 (225)	30 225
Tricia	Panel	Demo Converted End	Radial Edge	Rejector Disabled	True	False
Tricia	Panel	Demo Converted End	Ring/VO	Inspection Disabled	False	True

**Details** 

## Rollback



This feature allows you to restore the part program to a previous state, allowing you to undo several changes at once.

### ➤ To use the Rollback feature:

- Check the box next to the Rollback button at the top of the Part Change Log Viewer screen.
- Scroll down towards the bottom of the inspection list. The latest changes are at the bottom of the list.
- Choose a line where you want to delete the latest changes, including the selected line.
- Click the Rollback button near the top of the screen. A Rollback Preview is displayed so that you can see what will be deleted.

**Rollback Preview**

Type	Time Stamp	User	Camera/Sensor	Inspection	Parameter	Before	After
Edit	2010-12-28 17:17:31	Administrator	Nickel	Cartoon	Contrast Levels	G:30.74 W:30.52 E:G:12.51 W:22.78 E:	
Edit	2010-12-28 17:17:31	Administrator	Nickel	Polygon	Polygon Points	Changed	
Delete	2010-12-28 17:17:31	Administrator	Nickel	Ring			
Delete	2010-12-28 17:17:31	Administrator	Nickel	Clipping			
Delete	2010-12-28 17:17:31	Administrator	Nickel	Clipping			

**Details**  

- If desired, click the Details button to see the inspection change details of each line.
- If you are ready to delete the displayed lines, click the OK button . The lines are deleted, and the part program is changed back to a previous state.

## Inspection type icons

In the Inspection tree, you may see icons or symbols that indicate the General Type of inspection for each item. These allow you to quickly identify these inspections, without the need to view more information through the menus.

❖ *Note: these are options. To enable icons or symbols, right-click on a Sensor button in the Sensor Overview mode and select Options >> check Show Icons or Show Symbols.*

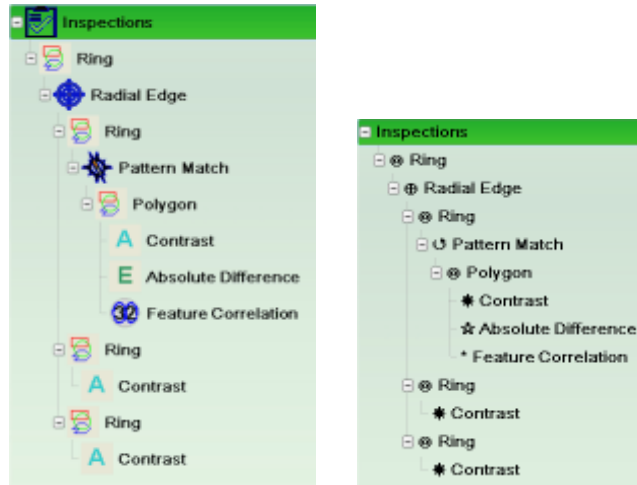

Icon	Symbol	General Inspection Type
		Region - location of inspection
		Registration - to find part center or point of reference
		Analysis - inspection
		Correlation - inspection to correlate a part to the machine part where it was made
		Orientation - to place an inspection on the same location on each part, regardless of part rotation
		Enhancement - to add image processing to make defects or part features stand out better
		Intellispec Mass inspection

## Options (sensor menu)

The Sensor Options menu allows you to display the inspection tree the best way for you. Some options hide objects from the inspection tree which makes it easier for adjustments. Other options display icons or symbols to help you quickly identify inspection types.

❖ *Note: these settings apply to the current sensor view only.*

### ➤ To enable an option:

1. From the Sensor Overview mode, right-click a Sensor button.
2. Select Options >> then select one of the options described below. An option is enabled when a check mark is displayed next to the option.

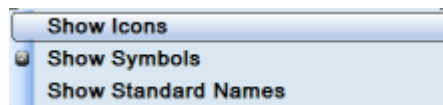

### Show Icons

Displays icons that reflect the different *inspection types* (see "*Inspection type icons*" on page 176).

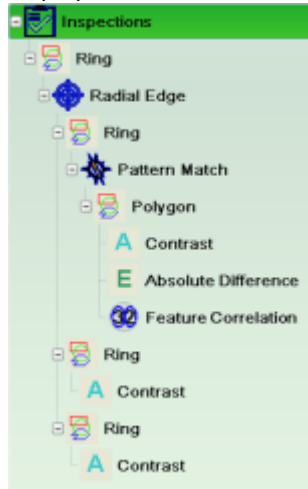

### Show Symbols

Displays symbols that reflect the different *inspection types* (see "*Inspection type icons*" on page 176).

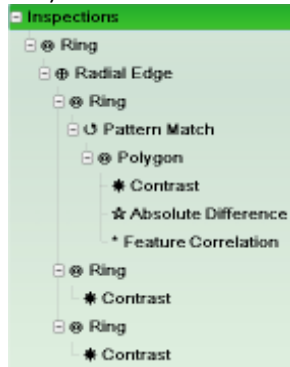

### Show Standard Names

Displays the default Intellispec inspection names. You may have other inspection names that make sense to the inspection of your part. Showing Standard Names is useful to Pressco engineers or to someone troubleshooting your machine, so that they quickly know the exact inspection type.

---

## Inspection Tree Relationships

The inspection tree shows the relationship of each inspection. Indented objects are dependent on the object above it. Indented objects are created when you "Add" an item from the Inspection menu.

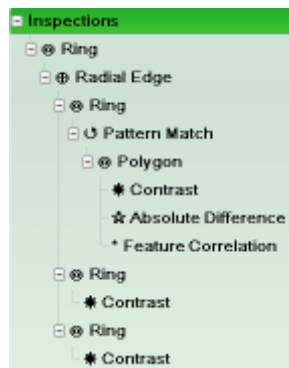

Some items in the menu may be turned off. The ability to access some items depends on your user access.

Inspection tree items may be highlighted in different colors. Below is a key.



a	Inspection in normal state
b	Inspection is an empty pocket check
c	Inspection reject is disabled
d	Inspection is disabled
e	Inspection is currently selected by the cursor

## Design Mode Icon

The **Design Mode** icon provides additional part program restrictions. Click the icon to see the options.

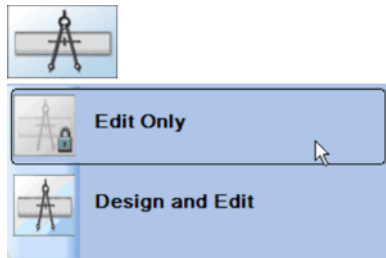

- If you select **Edit Only**, then users are allowed to edit, but not add, the inspections. This also restricts access to regions.
- If you select **Design and Edit**, then users are allowed to edit and add inspections, as well as add and edit regions.

❖ *Note: some users (for example, Operators) cannot edit or add inspections regardless of this setting. To add and edit inspections in Design and Edit mode, users must also have proper permissions. See Managing Permissions.*

See also **how to create a part program** (see "**How to Create, Copy, or Import a Part Program**" on page 168)

## Adding Regions and Inspections

To add an Analysis, Enhancement, etc., you must first add a Region. The Region indicates where on the part Analyses or Enhancements are applied. Right-click over the inspection tree, select Add, then choose an item to add. You may add as many inspections underneath the region as you wish.

# Region Editor

This view is available when you are editing a region. If you have proper user access, you can edit a region by double-clicking the region name, or right-clicking the region name, then selecting Edit Region from the pop-up menu.

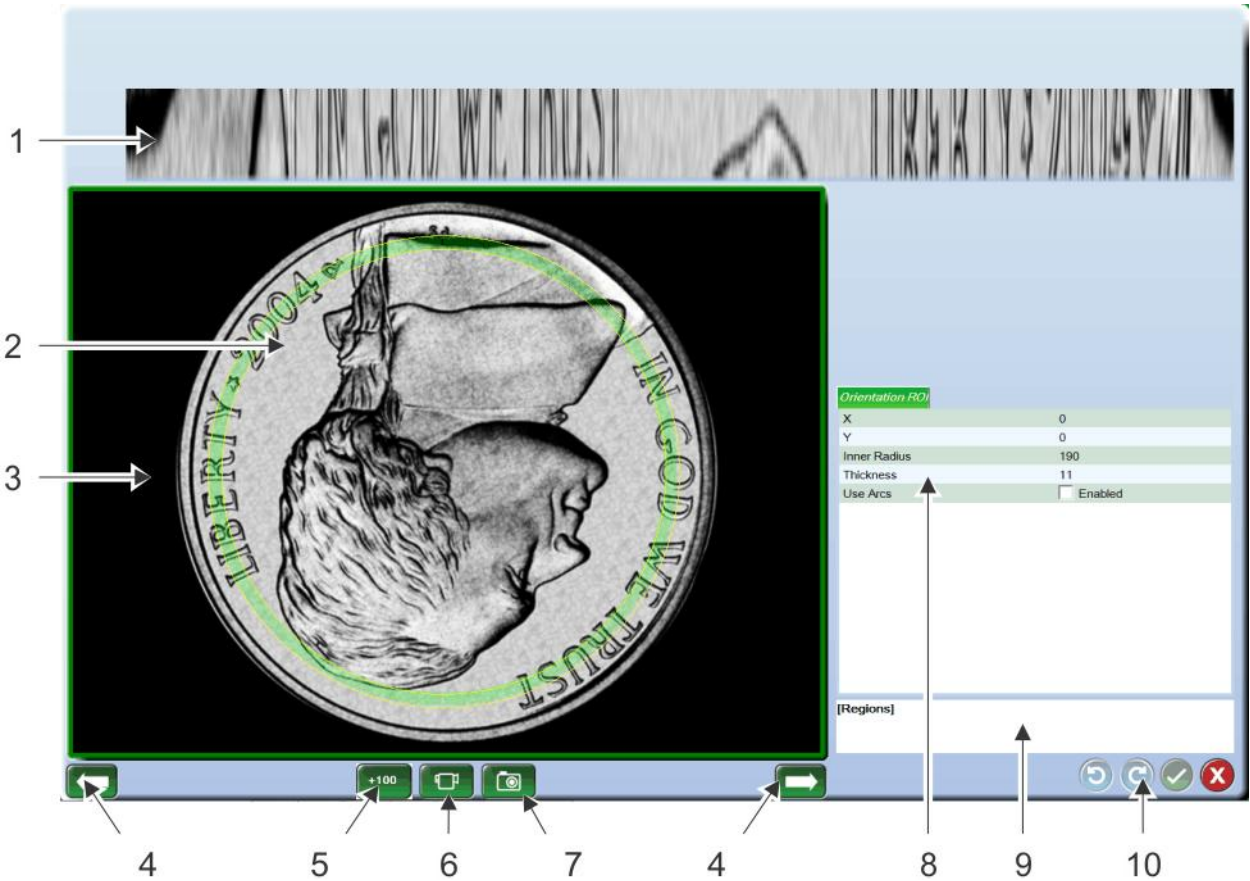

❖ Note: In Region editor, you will not see anything happen if you click numbers 5, 6, or 7. The data set is changed, but you will not see the data set until you view the **Inspection Editor** (on page 181).

1	Unwrapped Region of Interest	Displays a linear view of the region from the edited inspection.
2	Part Image	Displays a view of the part with the editable region on the part.
3	Editable Region	This is the region on the image that can be edited. When the lines are yellow, they can be edited. To enable region editing, right-click on the region and check "Enable Region Editor." The region can be sized and moved using the track ball and buttons or by using the optional touch screen.
4	Previous and Next Image	Allows you to select the next or previous image.
5	Get 100 images	Takes up to 100 images with the current sensor and replaces Data Set A.
6	Refresh Data Set	Takes up to 100 images with the current sensor and replaces Data Set A. When you click this button, the images are refreshed. They will continue to be refreshed until you click the button again.
7	Snap Image	Takes one image with the sensor and adds it to the end of Data Set A.

8	Editable Parameters	Adjust different parameters associated with the current region.
9	Parameter Description Window	Gives a brief description of the selected parameter.
10	Undo, Redo, Accept, and Cancel	Allows you to undo, redo, accept or cancel any changes made throughout the process of editing.

## Inspection Editor

The following illustration shows the various parts of the screen displayed when you edit an inspection.

❖ Note: the Retro-Spec graph (see "Retro-Spec Population View Graph" on page 185) at the top of the screen is described separately.

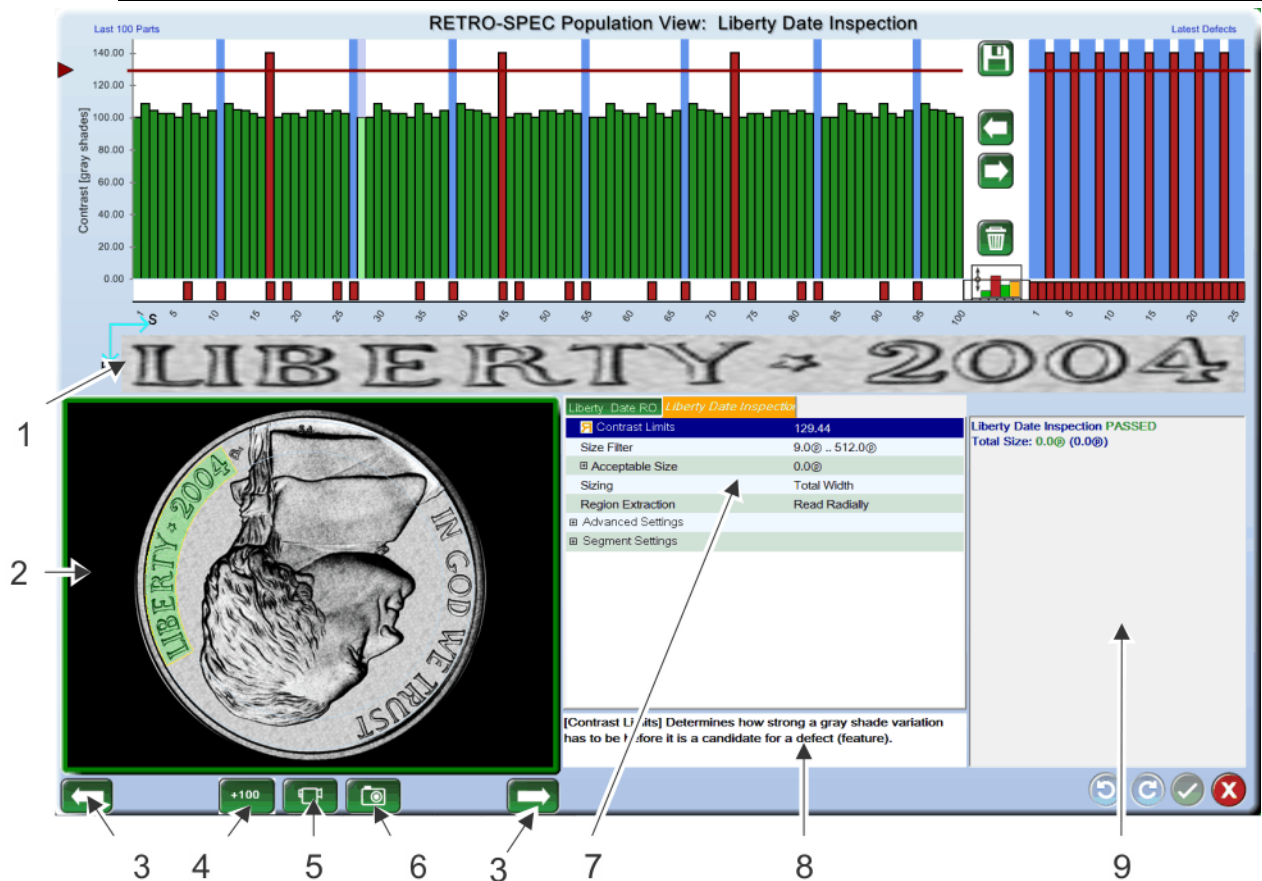

1	Unwrapped Region of Interest	Displays a linear view of the region from the edited inspection. This region is marked with two directions: "S" for "Slow direction" and "F" for "Fast direction." These designations are used in some inspection descriptions to help you understand how they work.
2	Part Image	Displays a view of the part with the editable region on the part.
3	Previous and Next Images	Allows you to select the next or previous image.
4	Get 100 images	Takes up to 100 images with the current sensor and replaces Data Set A.

5	Refresh Data Set	Takes up to 100 images with the current sensor and replaces Data Set A. When you click this button, the images are refreshed. They will continue to be refreshed until you click the button again.
6	Snap Image	Takes one image with the sensor and adds it to the end of Data Set A.
7	Inspection Parameters	Displays the available parameters for the selected inspection. Note: there can be multiple tabs; the parameters will vary per inspection.
8	Parameter Description Window	Gives a brief description of the selected parameter.
9	Results Box	Shows the results from the current inspection with the option to see results from other inspections and timing information.

Right-click over the various areas of the menu to see image options, editor options, result options, and region of interest options.

## Editing Parameters

You can change values, display settings, and options that will alter the outcome of an inspection. For the purpose of this discussion, we refer to **inspections**, but the information applies to regions, registrations, orientations, enhancements, measurements, and correlations as well.

❖ *Note: you must have appropriate user permissions to edit parameters*

### ➤ To edit parameters:

Open the inspection from the Sensor Overview screen:

- Double-click the inspection name in the inspection tree. Or:
- Right-click the inspection and select Edit Inspection from the pop-up menu.

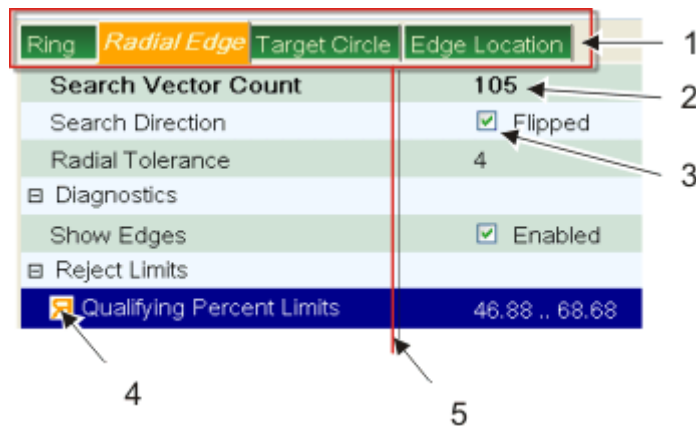

1	Select a tab to adjust parameters. The orange tab contains the parameters that can be adjusted with the bars on the Retro-Spec graph. The tabs displayed depend on the inspection itself, and its relationship within the inspection tree.
2	Numeric value can be adjusted by Large Slider or Numeric Text Entry [described below]
3	Check box to enable or disable the feature
4	Backwards R indicates the current parameter that can be adjusted in the Retro-Spec graph (example: the red and yellow limits bars). Note that you can also adjust parameter limits by right-clicking over the Retro-Spec graph.

5	Column division for parameter settings (this line is not actually displayed in the Intellispec). You can see Large Slider AND numeric entry pad if you click in the left column, or just the numeric entry pad if you click in the right column (this only applies if Numeric Input setting = both).
---	--

There are several ways to change parameters:

- Numeric values
- Check boxes
- Drop-down menus
- Buttons
- Adjusting the bars on the Retro-Spec graph

❖ *Note: Drop-down menus and buttons are discussed separately in the inspections where they are used*

## Editing Numeric Values

There are a few ways in which to change values and settings which include large slider, numeric text entry, or drop down. The method available depends on **Editor Options** as described below.

### Large Slider

Allows you to make changes using a sliding bar. It displays the value in the menu as you slide the bar. Changes made on the Large Slider are reflected in the Numeric Text Entry as well if both are open. Changes are also applied to the red and yellow sensitivity bars in the Retro-Spec graph. If the parameter has an upper and lower limit, portions of the bar are displayed in different colors, as shown below:



- Red = failure limit. Any part whose parameter value falls in the red zone fails inspection.
- Yellow = warning limit. Any part whose parameter value falls in the yellow zone is tagged as a warning level part.
- Green = passing. Any part whose parameter value falls in the green zone passes (at least this parameter).

### Numeric Text Entry

Allows you to type in a specific number. You can use the +1 and -1 feature to make minor adjustments. Changes made on the Numeric Text Entry are reflected in the Large Slider as well if both are open.

For more information about the numeric keyboard, see **On Screen Keyboard (OSK)** (on page 34)

## Editor Options

The information displayed when you are editing parameters depends on the Editor Options settings. Right-click over the parameters menu to see the Editor Options.

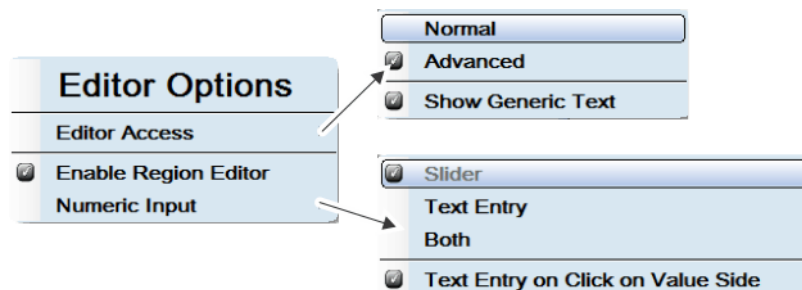

### Editor Access

Choose how menus are displayed:

- **Normal** - display the normal menus (for most users)
- **Advanced** - display the advanced parameters (for power users)

❖ *Note: you must have the appropriate permissions to see the advanced parameters: "Access advanced inspection parameters"*

- **Show Generic Text** - default Intellispec names. Some parameter names were changed in templates to make more sense for a particular application.

### Enable Region Editor

Available when the inspection has an associated region that can be modified.

### Numeric Input

- Slider = Large Slider as described above
- Text Entry = Numeric Text Entry as described above
- Both = both Large Slider and Numeric Text entry. After you make changes to either input, you must click the OK button  on both to close them.
- Text entry on click on value side = if you click an item the right column of the menu, you will see only the Numeric Text Entry box, even if you have Both checked

## Result Options

There is additional display information for the Results Box. Right-click to see the menu. To stop displaying the other inspections, right-click the menu again, then un-check the option.

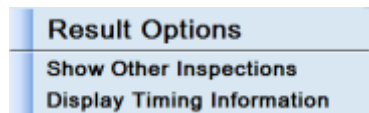

### Show Other Inspections

Displays whether a part has passed or failed other inspections on the current sensor. Right-click the menu again to see the option to hide good inspections. If that option is checked, then only the failed inspections are displayed.



Inspection	Result
Ring	Good
Radial Edge	Good
Measurement	Not Com...
Measure Extract	Not Com...
Ring	Good
Pattern Match	Bad
Polygon	Bad
Contrast	Bad
Polygon	Bad
Contrast	Bad
Polygon	Bad
Contrast	Bad
Polygon	Bad
Ambient	Bad

### Display Timing Information

Displays timing information for each inspection on the current sensor and the total time in milliseconds.

## Unwrapped Region of Interest Options

Right-click in the Unwrapped Region of Interest to display the region of interest (ROI) options menu. To stop displaying either option, right-click the menu again and un-check the option.

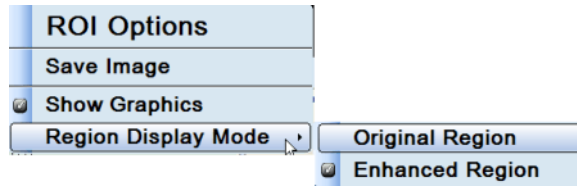

Save Image (see "Saving a Region of Interest (Unwrapped) Image" on page 162)

Save the Region of Interest image.

### Show Graphics

Displays any graphics that are selected, like vectors or edges, on the Unwrapped Region of Interest.

### Region Display Mode

Gives you the option to show the original region, or the enhanced region, if it has an enhancement.

---

## Retro-Spec Population View Graph

The Retro-Spec graph is displayed when you edit a Registration, Orientation, or Inspection.

The Retro-Spec Graph can display up to 200 parts at a time, 100 in each set. Each bar on the graph represents a different part. A green bar means that the part has passed. A yellow bar means that the part has exceeded the warning limit but not the reject limit. A red bar means that the part has exceeded the reject limit. A lighter shade of green, red or yellow will be displayed when a part is selected. To select a part, simply click on a bar in the graph. When you click a bar, the part's unique Part Image, Unwrapped Region of Interest, and Results will be displayed.

### Population View

Displays details for up to the last 200 parts. The parts can be the last 100 run, the latest 100 defects for the inspection, or a set of parts previously saved to the hard drive.

### Graphs with One Reject Bar

Some inspections have one reject bar on the Retro-Spec Graph. The Warning/Reject Bar can be a minimum requirement where the part Retro-Spec value must be higher than the reject bar in order to pass. The Warning/Reject Bar can also be a maximum requirement where the part Retro-spec value cannot exceed the reject bar in order to pass.

### Graphs with Two Reject Bars

Some inspections have two reject bars. The part's value must be between the two reject limits to be considered a good part. The example below shows an ambient inspection with two reject bars (red) and two warning bars (yellow).



The components of the Retro-Spec graph are as follows:

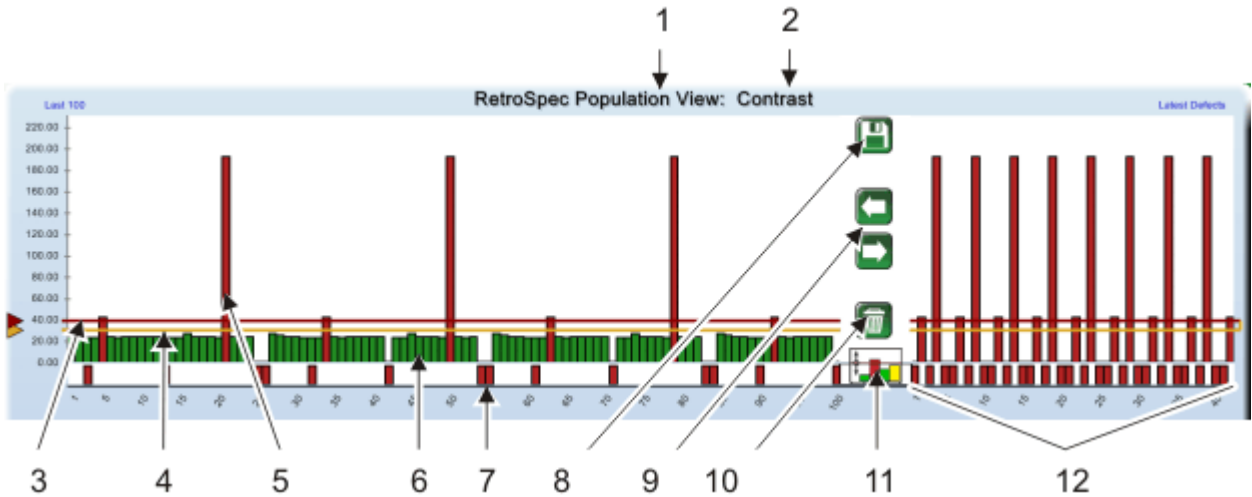

1	Selected View	Shows which Retro-Spec graph view is being displayed.
2	Selected Inspection	Shows the type of inspection.
3	Reject Bar (red)	Shows the inspection limits. Parts that fall outside the reject limits are considered defective.
4	Warning Bar (yellow)	Shows the inspection warning limits. Parts that fall outside the warning limits are not considered defective, but are approaching reject status.
5	Reject Part	Reject Parts are displayed in Red.
	Warning Part	Warning Parts are displayed in Yellow. [not shown in this example]
6	Passing Part	Passing Parts are displayed in Green.
7	Other Results Indicator	Indicates whether a part has failed or had a warning on a different inspection. A small red box will appear under a part that has failed a different inspection. A small yellow box will appear under a part that has had a warning from a different inspection.
8	Save Parts	Allows you to save a set of parts which can be reloaded later. You can save the Selected Parts, Set A, or Set B. You can also choose where to save them by clicking the Save Parts button under "Where to save?"
9	Select Parts	Allows you to select a set of parts, set A or Set B, to be displayed in the Retro-spec Graph. Clicking on either the left or right arrow will bring up the Select Parts Menu below. You can choose from Last 100, Latest Defects, or Custom Set.
10	Delete Part [Trash can icon]	Gives you the ability to delete a single part. Can only be used when the lock [item 11] is unlocked. To delete a part: highlight the part, then click the trash can icon, or highlight the part then drag it to the trash can icon and release the trackball button. A message appears above the icon stating that the part has been deleted.
11	Lock/ Move Parts Toggles to: 	When the graph is locked, parts cannot be moved or deleted. When the graph is unlocked, part sets can be modified. Parts can be saved, moved within the same set, moved to the set on the other side of the divider, or deleted. Dragging the part to the Select Parts arrows [item 9] will move the part into the corresponding side. Dragging the part to the Save Parts button will allow you to save the part. Dragging the part to the Delete Parts button will delete the part.
12	Data Set B	The parts on the right side of the divider make up data Set B.

Once a part has been deleted or moved, the term **\*\*Scratch Parts\*\*** is displayed at the top of the data set. To save the data set with your changes, click the Save Parts icon [item 8]. This will allow you to save the data set on either side of the divider, or just the selected parts.

## Retro-Spec Options

Right-click the Retro-Spec graph to see the Retro-Spec options menu.

❖ *Note: some options are not displayed if they are not applicable to the current inspection.*

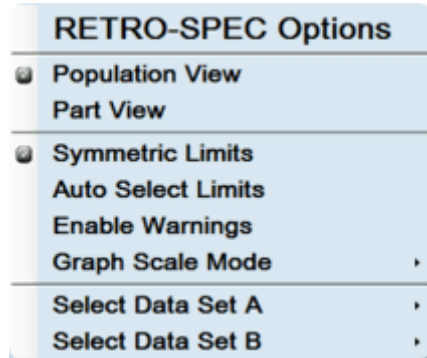

### Population View

When this is checked, the **Retro-Spec population view graph** (on page 185) is displayed.

### Part View

When this is checked, the Retro-Spec part view graph is displayed.

### Symmetric Limits

When the Retro-Spec graph has upper and lower limits (two red bars and two yellow bars), this option keeps the upper and lower limits the same distance from nominal.

### Lock Warnings to Errors

Locks the yellow warning bar to the red reject bar in the Retro-Spec graph, keeping them the same distance apart.

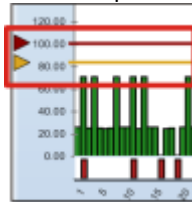

### Auto Select Limits

Automatically adjusts warning and reject levels to make all parts in the data set pass.

### Enable Warnings

Provides a warning level (yellow) sensitivity bar. A warning level does not reject parts, but indicates that the process is approaching the reject status. When you enable warnings, they are enabled for all inspections for the current sensor.

### Graph Scale Mode

Change the height scale of the graph.

**Limits Only** displays part parameter values up to and including the current inspection limits. This is useful when you want to zoom in on data without extra lines on the graph. Note that the limit lines may not be displayed on the graph. As soon as you change the parameter limits from the menu, the limit lines are displayed again on the graph.

**Limits and Data** is the default mode that displays all the inspection data plus the limit lines.

### Select Data Set A or B

For each Data Set, you can select what you want to display. You can choose to display Nothing, Last 100 Parts, Latest Defects, a Freeze on Defect image, or a set of Image Files that have been previously saved to the computer.

See information about **Saving Images** (see "**Saving Images through the Retro-Spec interface**" on page 153). See also Freeze on Defect Image in Retro-Spec.

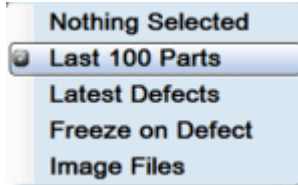

### Select Parameter

Choose a graph to display. This is available for some inspections where you have a choice to display different graphs. An example is Measurement Analysis, where there are several different measurement graphs available, as shown below. Another example is in the BMID inspection.

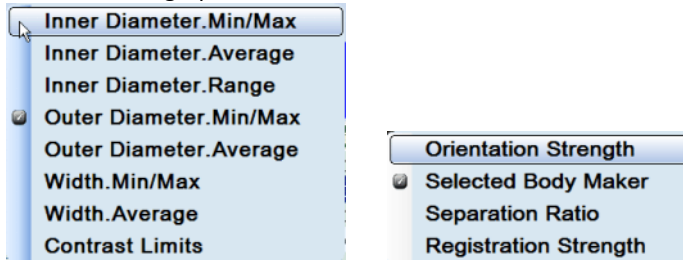

## Retro-Spec Part View Graph

The Part View shows specific information unique to each part. To display the Part View, right click on a part and choose Population View, or double-click a part from the Population View. There are different types of Part Views that vary by inspection.

❖ *Note: not all inspections have a Part View graph available.*

Shown below is the Part View of a **Contrast** inspection. It has a reject bar and an Unwrapped Region of Interest. Any type of damage to the surface of the part, which can be seen in the Unwrapped Region of Interest, will have a corresponding value on the graph. If any part of the graph exceeds the Reject Bar, the whole part will be considered a defective image. The Reject Bar can be dragged, changing the actual reject threshold.

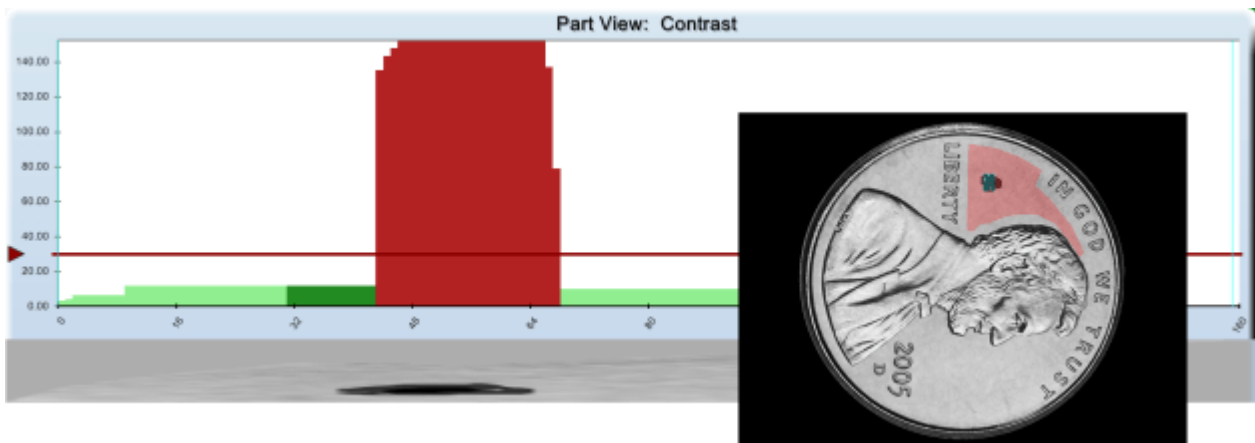

Shown below is a Part View of an **Ambient** inspection. This Part View does not have a reject bar but does have an Unwrapped Region of Interest. The graph does not correspond to Gray Shades on the Unwrapped Region of Interest. The graph represents how many pixels of each Gray Shade are found on the part.

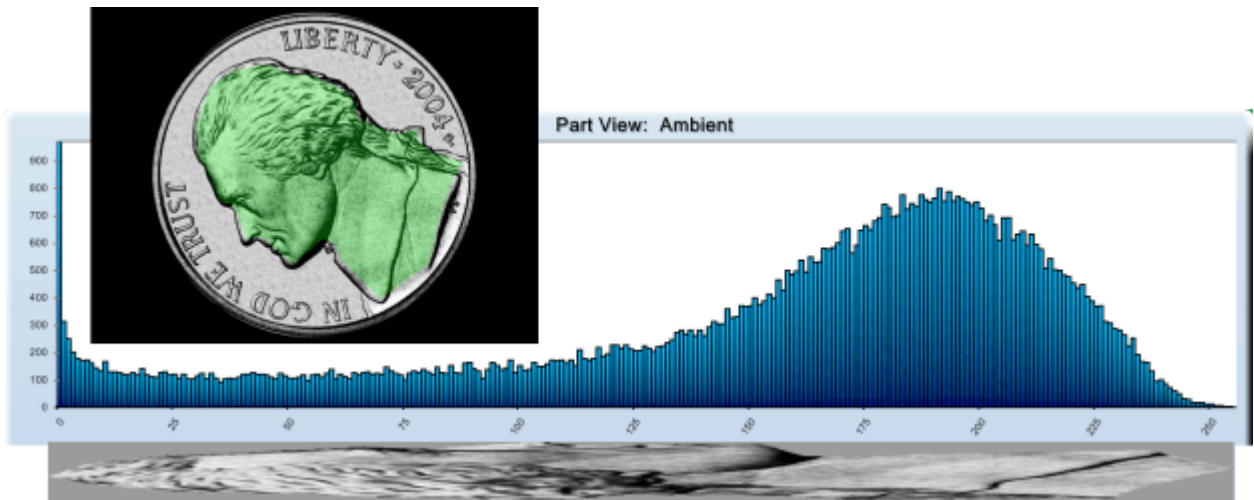



# Chapter 13

## Inspections

This section covers regions of interest, registrations, orientations, enhancements, analyses, dimensions, and correlations. We use the term **inspections** to include all of these items, for simplicity.

The information in this section is valid as of software version 5.0.501.

### Empty Pocket

The Empty Pocket feature checks to see whether a part is present or not. This is used for applications where you must determine whether a part is present before proceeding with inspection. A common use for this test is in Starwheel applications where the encoder is used, based on pocket position, rather than a part present signal. Locating an empty pocket is important for production numbers to be accurate. If an empty pocket is found, no inspection takes place for that pocket. Otherwise, an empty pocket would be recorded as a defect.

Notes:

- You may run the Empty Pocket check on any inspection. We recommend that you use it with an inspection that has pass/fail criteria. Ambient and Contrast inspections are most commonly used.
- You may add as many empty pocket checks to the part program as desired.

➤ **To add an Empty Pocket check to an existing part program:**

1. In the inspection tree, right-click over the name of the inspection to which you want to add the Empty Pocket check.
2. From the Inspection menu, select the "Is Empty Pocket Check?" menu item. The "Yes" item will be checked. That inspection is highlighted in blue, and will remain highlighted unless you disable the Empty Pocket check. The item toggles between Yes and No to enable or disable the feature.

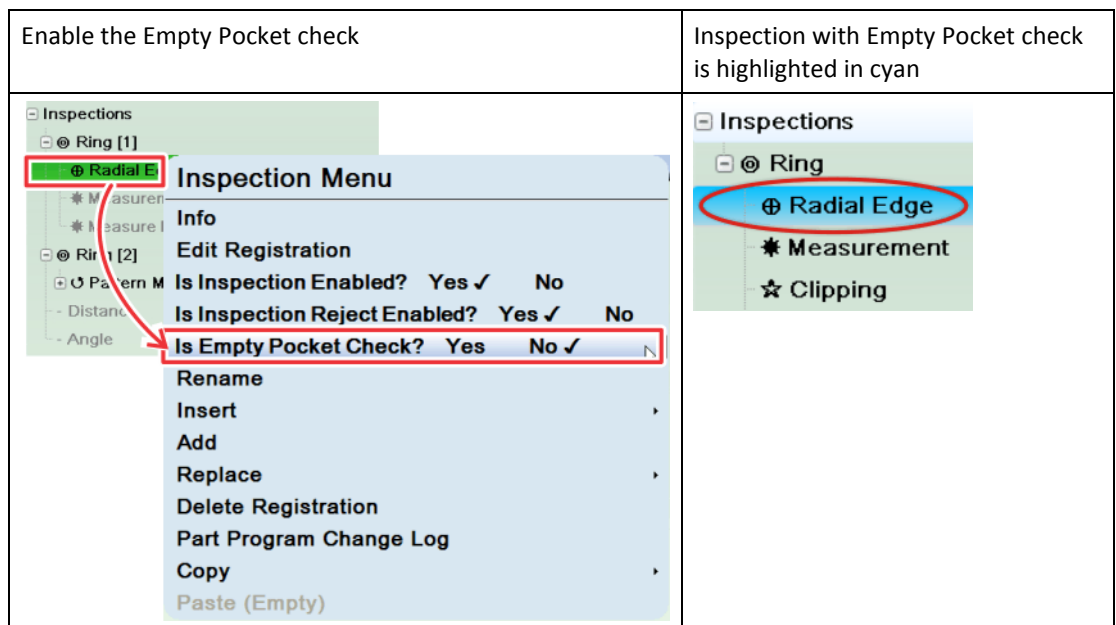

### Statistics updates using Empty Pocket

To make sure that the statistics totals do not count empty pockets as defects, you must set up an Empty Pocket check for all sensors in each lane. For example, if you have three sensors in Lane 1, all three sensor part programs must contain an Empty Pocket check.

The statistics are counted as an OR function. If any of the sensors within a lane detects an empty pocket, then that part ID is not counted in the defect statistics.

## Regions of Interest (ROI)

Regions of Interest (ROI) are the locations where the registrations, analyses, and orientations take place. There is no inspection done in a Region of Interest. However, there is no limit to the number of inspections that can be placed in one Region of Interest.

There are up to five region types available to set up the region of interest on a part. All regions can be edited directly on the image (after adding them to the inspection list).

❖ *Note: Your system (and this book) may show only those items that apply to your application.*

- **Ring Region** (on page 193)
- **Polygon Region** (on page 194)
- **Ribbon Region** (on page 196)
- **Measure ROI** (on page 198)
- **Adaptive Region** (on page 200)

## Region of Interest Compatibility Chart

The following chart shows whether each inspection is compatible with each region type.

Region Type:	Ring	Polygon	Ribbon	Measure ROI	Adaptive
<b>Enhancements (All)</b>	Yes	Yes	Yes	Yes	Yes
<b>Registrations</b>					
Feature	Yes	Yes		Yes	Yes
Center of Mass	Yes		Yes		Yes
Hough	Yes				
Radial Edge	Yes				
Centerline			Yes		
Finish Location			Yes		
Template Registration	Yes	Yes		Yes	
Support Ring Registration				Yes	
<b>Orientations</b>					
Pattern Match	Yes				
Template Orientation	Yes				
<b>Analyses</b>					
Ambient	Yes	Yes	Yes	Yes	Yes
Shape Check					Yes
Contrast	Yes	Yes	Yes	Yes	Yes
Measurement	Yes		Yes		Yes
Light Meter	Yes	Yes	Yes	Yes	Yes

Region Type:	Ring	Polygon	Ribbon	Measure ROI	Adaptive
Fill Height				Yes	
Measure Extract	Yes	Yes	Yes	Yes	Yes
Distribution	Yes	Yes	Yes	Yes	Yes
Label Skew Extract	Yes	Yes	Yes	Yes	Yes
Feature Detect	Yes	Yes			Yes
<b>Dimensions (All)</b>	Dimensions do not use regions; they get data from other inspections.				

## Ring Region

The Ring region is circular or donut-shaped. You can create arcs or multiple arc segments in the region. The inner and outer radii are adjustable, and the region's position is adjustable.



### ➤ To add a Ring Region:

1. If you plan to use Arcs for the Ring Region, place an **Orientation** (see "**Orientations**" on page 243) in the inspection tree. If you want the region to be circular or donut-shaped, skip the Orientation.
2. Highlight the Orientation name in the inspection tree (if applicable).
3. Right-click on the item you just added.
4. From the Inspection menu, select Add > Region > Ring. Re-name it to something more meaningful to you.
5. The Ring Menu is displayed and the ring is shown on the image. (The menu is described below) Adjust the placement of the ring and parameters as necessary.

### Ring menu

<b>Ring</b>	
X	0
Y	0
Inner Radius	179
Thickness	92
<b>Use Arcs</b>	<input checked="" type="checkbox"/> Enabled
Start Angle	0.0°
Stop Angle	0.0°
Arc Count	1
Arc Alignment	Align to boundary

The following parameters can be set graphically (on the image), or through a slider bar or numeric keypad, which pop up when you click on a numeric value. Also refer to more information about **Editing Parameters** (on page 182).

#### X and Y position

Horizontal and vertical position of the center of the ring on the image.

### Inner Radius

Size of the inner ring.

### Thickness

The thickness of the ring; outer radius minus inner radius.

### Use Arcs

Allows you to inspect an arc instead of the whole region. The system will inspect a segment of the region between the Start and Stop angles. Make sure you have an Orientation in the job prior to using arcs. This will ensure that the inspection region is placed on the same location of the part regardless of the part's orientation.

The following parameters are available when Use Arcs is enabled.

### Start Angle

The start angle of the region.

### Stop Angle

The stop angle of the region

### Arc Count

Set the number of segments you want to create in the region.

### Arc Alignment

Not currently used.

## Polygon Region

Similar to the **Ribbon Region** (on page 196), the Polygon Region is a customizable region that is used for:

- free-form inspection areas on a part
- areas that do not fit a circle or other standard inspection region

❖ *Note: we recommend that you place a Registration and Orientation (if applicable) prior to adding a polygon region. This will ensure that the polygon is placed correctly on the part, regardless of the part's placement or rotation.*

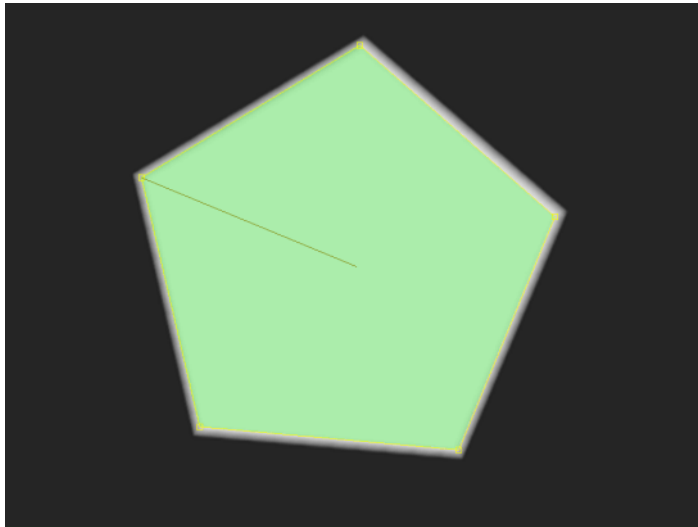

### ➤ To add a Polygon Region:

1. Make sure that the part program has a registration and/or orientation in place to ensure proper placement of the polygon on all inspected parts.
2. Highlight the Registration or Orientation name in the inspection tree.
3. Right-click on the item you just added.
4. From the Inspection menu, select Add > Region > Polygon. Re-name it to something more meaningful to you.

5. A "NEW POLYGON: Click to add points" message is displayed in the large image area, and the Polygon Menu is displayed. (The menu is described below) Click anywhere in the image to start the polygon.
6. Continue clicking with the yellow boxes (polygon points) to create a polygon region. You may create as many points as you like.
7. When you want to close the region, click on the first box that you placed. The region closes and is filled in for you.

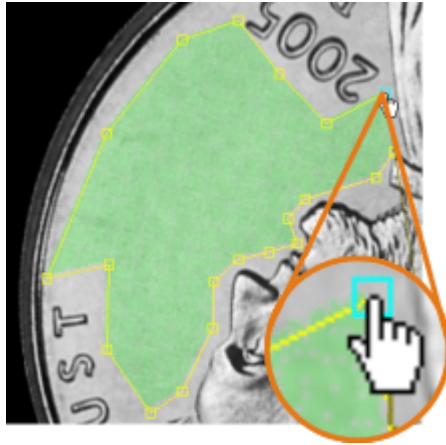

8. Make any necessary adjustments from the menu (described below). You can make adjustments to the region, duplicate it, or rotate it from the menu.

➤ **To edit the polygon region:**

Right-click the image to view the **Image Options** (on page 164) menu. Use Edit Mode to Delete, Add, or Move any polygon point or the entire region.

### Polygon menu

Polygon	
Repeat Polygons	<input checked="" type="checkbox"/> Enabled
Repeat Count	1
Rotate Polygon	0.0°
Expand or Contract	0

#### Repeat Polygons

Create duplicate copies of the original polygon. Allows from 1 to 10 polygons that are centered and rotated around the registered position.

#### Repeat Count

(Available when using multiple polygons) Choose the number of duplicate polygons to place on the image. The system automatically distributes these polygons around the image. A common use for this feature is for the feet of a PET bottle.

#### Rotate Polygon

Rotate the polygon around the center of the polygon. If you have duplicate polygons, they are also rotated.

#### Expand or Contract

Resize the region. A negative number contracts the region, and a positive number expands the region.

❖ *Note: be careful not to contract the region too much. This will distort the original shape.*

## Ribbon Region

Similar to the **Polygon Region** (on page 194), the Ribbon Region is a customizable region and can come in two different forms: ribbon, and loop. This type of region is used for:

- free-form inspection areas on a part
- areas that do not fit a circle or other standard inspection region

❖ *Note: we recommend that you place a Registration and Orientation (if applicable) prior to adding a Ribbon region. This will ensure that the ribbon is placed correctly on the part, regardless of the part's placement or rotation.*

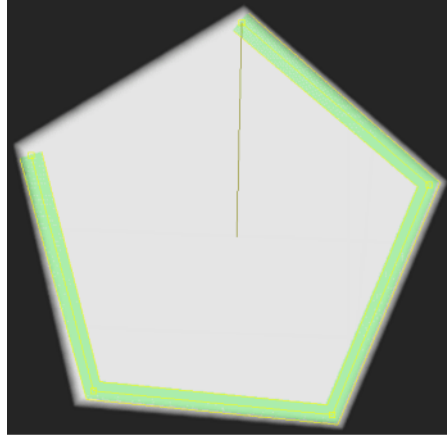

1

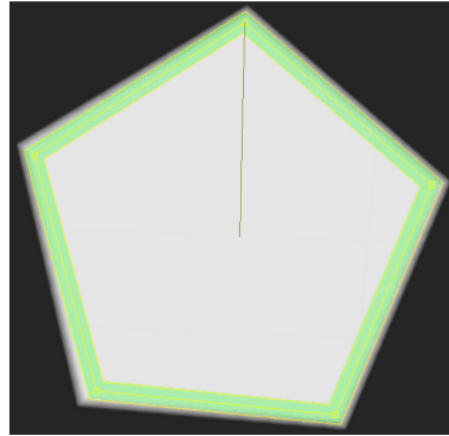

2

1	<b>Ribbon</b> - a customizable region that does not close, similar to a rubber band that has been cut. Thickness remains the same throughout the region.
2	<b>Loop</b> - a closed version of the ribbon region, similar to a rubber band. Thickness remains the same throughout the region.

### ➤ *To add a Ribbon Region:*

1. Make sure that the part program has a registration and/or orientation in place to ensure proper placement of the region on all inspected parts.
2. Highlight the Registration or Orientation name in the inspection tree.
3. Right-click on the item you just added.
4. From the Inspection menu, select Add > Region > Ribbon. Re-name it to something more meaningful to you.
5. A "NEW RIBBON: Click to add points" message is displayed in the large image area, and the Ribbon Menu is displayed. (The menu is described below) If you want to change the ribbon type to Loop, use the Ribbon Style drop-down item in the menu.
6. Click anywhere in the image to start the ribbon.
7. Continue clicking with the yellow boxes (ribbon points) to create a ribbon region. You may create as many points as you like.
8. When you want to close the region, right-click on the image to view the Image Options menu and select Complete New Ribbon. The region closes and is filled in for you.
9. Make any necessary adjustments from the menu (described below). You can make adjustments to the region, duplicate it, or rotate it from the menu.

### ➤ *To edit the ribbon region:*

Right-click the image to view the **Image Options** (on page 164) menu. Use Edit Mode to Delete, Add, or Move any ribbon point or the entire region.

## Ribbon menu

Ribbon	
Ribbon Style	Loop
Ribbon Width	20
Repeat Ribbons	<input type="checkbox"/> Enabled
Mirror Ribbon	<input type="checkbox"/> Enabled
Rotate Ribbon	0.0°
Expand or Contract	0

### Ribbon Style

Choose between Ribbon and Loop as described above.

### Ribbon Width

Set the width of the region.

### Repeat Ribbons

Create duplicate copies of the original ribbon. Allows from 1 to 10 ribbons that are centered and rotated around the registered position.

### Mirror Ribbon

(Only used when Repeat Ribbons is disabled) Create a flipped duplicate of the region. This is typically used for the **Centerline** (on page 225) Registration where two sides are being searched for.

### Mirror Angle

(Only used with Mirror Ribbon) Flip the mirrored region horizontally (90 degrees), vertically (zero degrees), or any angle in between.

### Mirror Offset

(Only used with Mirror Ribbon) Move the mirrored region further or closer together.

### Repeat Count

(Available when using multiple ribbons) Choose the number of duplicate ribbons to place on the image. The system automatically distributes these ribbons around the image. A common use for this feature is for the feet of a PET bottle.

### Rotate Ribbon

Rotate the ribbon around the center of the ribbon. If you have duplicate ribbons, they are also rotated.

### Expand or Contract

Resize the region. A negative number contracts the region, and a positive number expands the region.

❖ *Note: be careful not to contract the region too much. This will distort the original shape.*

## Measure ROI

Measure ROI(s) is a region that is intended to be used in measurement type operations (such as **Label Skew Extract** (on page 282), **Measure Extract** (on page 275), **Fill Height** (on page 269), and Support Ring Registration or Neckring Registration).

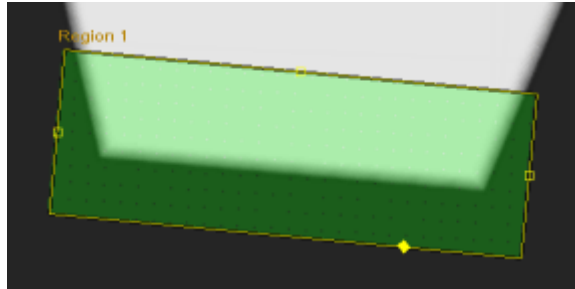

### ➤ To add a Measure ROI Region:

❖ *Tip: We recommend that you first add a standard region of interest and registration to locate a reference point on the part. The Measure ROI region will then follow the correct location on the part.*

1. Highlight the Registration name (if one is available) in the inspection tree.
2. Right-click on the item you just added.
3. From the Inspection menu, select Add > Region > Measure ROI. The Measure ROI region is added to the inspection tree. Re-name it to something more meaningful to you.
4. The Measure ROI menu is displayed and the region is shown on the image. (The menu is described below) Adjust the placement of the region and parameters as necessary.

### Measure ROI menu

Measure ROI(s)	
Region Count	Two Regions
Vertical Lock Mode	Independent Movement
Horizontal Lock Mode	Independent Movement
Sizing Lock Mode	Independent Sizing
[-] Region 1	
Center Offset X	-100
Center Offset Y	-25
Region Width	100
Region Height	50
Region Angle	90.0
[-] Region 2	

#### Region Count

Leave this set at One Region unless you have a Fill Height application. Most measurements require one region. Fill Height applications require two regions: one for reference, and one for fill level.

#### Region 1 or 2

Contains the settings for each region.

#### Center Offset X and Y

Set the region offset value relative to the registered center. If your region is off the screen, you may need to change these values.

#### Region Width, Height, and Angle

Adjust the size and rotation of the region. You can also click on the image and adjust the region graphically (if Enable Region Editor is checked in the Image Options menu). To adjust, click and drag one of the empty yellow squares.

The Region Angle allows you to ensure that the region is a rectangle. After resizing and moving the region, it can become non-rectangular. Use the **Region Angle** parameter to quickly set to 0, 90, 180, or 270 degrees, to make the region a rectangle.

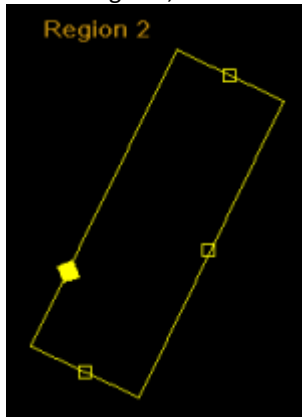

The Measure ROI is a two point polygon ribbon region. Refer to the illustration below. The end points [1] adjust the length of the ribbon. The point on the side of the region [2] adjusts the width of the ribbon. The diamond [3] indicates the direction towards which the vectors are searching.

❖ *Note: for the image below, both Enable Region Editor and Enable Region Size are checked in the Image Options menu. You view the yellow boxes and points when you click on the image to adjust the region size and/or position.*

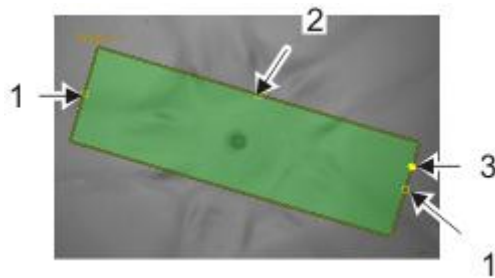

1	End points of the ribbon region
2	Point to adjust the width of the region
3	Indicates the direction towards which the vectors are searching

### **Additional menu items for Two Regions**

#### **Vertical Lock Mode, Horizontal Lock Mode, and Sizing Lock Mode**

Choose whether to move the two regions independently, or to lock the regions (move the regions together). When you choose to mirror the regions, the regions move in opposite directions.

## Image options Measure ROI

When you right-click the image you will see a slightly different image options menu for Measure ROI. Most of the menu items are the same as in the default **image options** (on page 164) menu. The last three items are different.

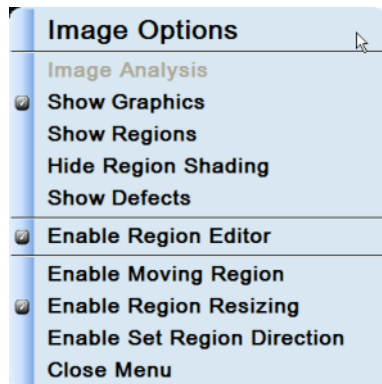

To avoid confusion, we recommend that you make each adjustment one at a time. For example, Enable Moving Region to move the region, then disable it. Then Enable Region Size to adjust the size, then disable it. Then Enable Region Direction to set the direction.

### Enable Moving Region

Enable Region Editor must be enabled before you can move the region. Click and drag the entire region.

### Enable Region Resizing

Adjust the region size by clicking on the image and moving the yellow points.

### Enable Set Region Direction

Click a diamond on any side of the ribbon to change the search direction for the **Measure Extract** (on page 275) inspection.

### Close Menu

Until you use Close Menu or click on the image, the Image Options menu stays open.

## Adaptive Region

This is a region that is built from the edge points found in registrations (except from Template Registration). The region adapts to whatever edge points are found. It can follow the shape of your part.

*Series IV users: this is similar to Tracker or Shape Adapt registrations.*

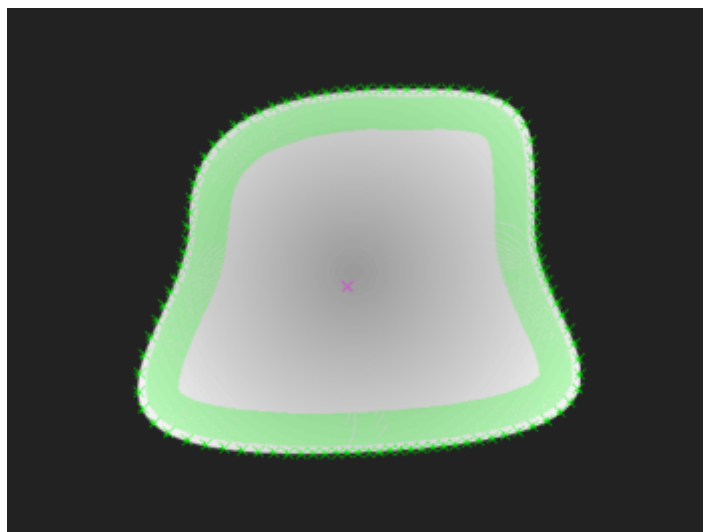

❖ *Note: Adaptive Region can be added only after one or more Registrations (on page 215).*

➤ **To add an Adaptive Region:**

1. Make sure at least one **Registration** (see "**Registrations**" on page 215) has been added to the inspection tree.
2. Highlight the Registration name in the inspection tree.
3. Right-click on the item you just added.
4. From the Inspection menu, select Add > Region > Adaptive. The Adaptive region is added to the inspection tree. Re-name to something more meaningful to you.
5. The Adaptive Menu is displayed and the region is shown on the image. (The menu is described below) Adjust the placement of the region and parameters as necessary.

## Adaptive menu

Adaptive	
Creation Mode	Adapting Region
Region Style	Polygon
Edge Offset	-12
Correction Mode	No Correction
▢ Diagnostics	
Show Found Edges	<input type="checkbox"/> Enabled
Show Corrected Edges	<input type="checkbox"/> Enabled
Show Region Edges	<input type="checkbox"/> Enabled

### Creation Mode

Choose whether to have the region adapt to each part as it is inspected [Adapting Region], or to find a region once and use it for all parts [Fixed Region]. Different menu parameters are available. Fixed Region is described below.

### Region Style

Choose the type of region you want to create from the registration results. Use the one best suited to the area you are inspecting. The options are described below.

**Fit to Circle** - A donut-shaped region is created.

❖ *Note: For descriptions of shapes, also refer to **Polygon Region** (on page 194) and **Ribbon Region** (on page 196). The difference in the Adaptive Region is that the shape is created using found registration points, rather than manually placed points, as is done in the standard Polygon or Ribbon Regions.*

**Polygon** - a free-form shape is created and filled in.

**Ribbon** - a free-form ribbon shape is created. The ends are open. You specify the width of the region.

**Loop** - a free-form shape is created. The ends are connected. You specify the width of the region.

**Custom 2 Sided Polygon** - a free-form shape is created and filled in. This shape should only be used after a Centerline registration. You have the option of creating separate offsets for each side. A common use for this is Preform sidewall inspections, where there is a dark area on either side of the preform in cameras one and three. With Custom 2 Sided Polygon, you could create the region to ignore that dark area.

### Edge Offset

Specify how many pixels away from the found registration points the Adaptive Region should be.

### Region Offset Side 2

(Used with Custom 2 Sided Polygon) Create a different offset for one side of the part. This is normally used for Preform sidewall inspections.

### Correction Mode

Correct the edge positions from one of the available techniques:

**No Correction** - uses the original registration positions.

**Simple Smoothing** - smooths the edges of the region.

**Circular Smoothing** - smooths the edges to form a circle.

**Dual Edge Correction** - (applies additional Correction Settings) this mode should only be used after a Centerline registration. It corrects missing and bad points in the two sets of edge locations (the two sides of the part).

**Bad Point Removal** - uses an additional **Correction Sensitivity** parameter. Removes bad points from the found edge positions. If an edge point does not fall within the specified sensitivity, it is removed from the Adaptive region.

### Correction Sensitivity

(used with Bad Point Removal) Adjust the sensitivity of the edge positions between 10 and 500. A smaller number means greater sensitivity.

## Diagnostics

### Show Found Edges

Display the found edges on the image.

### Show Corrected Edges

Show the edges that were corrected using Correction Mode.

### Show Region Edges

Show the location of the edges after using Region Offset.

## Correction Settings (Used with Dual Edge Correction)

### Maximum Deviation

Specify how many pixels an edge can be away from the found edge before applying edge correction.

### Learn Cross Section

Click the **Learn Distances** button to determine normal edge locations for that part.

## Fixed Region Adaptive menu

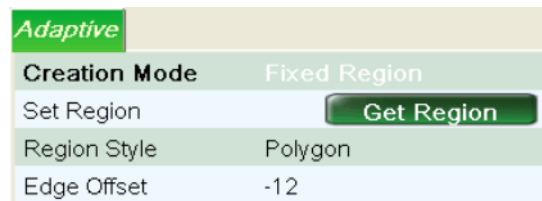

When you choose Fixed Region, the Intellispec will find the shape of the part once, then use that shape region for all remaining parts.

### ➤ To set a Fixed Region:

1. Select a Region Style.
2. Set the remaining parameters below Region Style as appropriate for your part.
3. Click the **Get Region** button to set the region based on the current part.

### Set Region

Click the **Get Region** button (after setting the Region Style and other parameters) to set the region based on the current part. The Intellispec finds the region edges for the current part and creates a polygon or other region style. That region is then used for inspection of all subsequent parts.

### Region Style

Choose the type of region you want to create from the registration results. Use the one best suited to the area you are inspecting. The options are described below.

**Fit to Circle** - A donut-shaped region is created.

❖ *Note: For descriptions of shapes, also refer to **Polygon Region** (on page 194) and **Ribbon Region** (on page 196). The difference in the Adaptive Region is that the shape is created using found registration points, rather than manually placed points, as is done in the standard Polygon or Ribbon Regions.*

**Polygon** - a free-form shape is created and filled in.

**Ribbon** - a free-form ribbon shape is created. The ends are open. You specify the width of the region.

**Loop** - a free-form shape is created. The ends are connected. You specify the width of the region.

**Custom 2 Sided Polygon** - a free-form shape is created and filled in. This shape should only be used after a Centerline registration. You have the option of creating separate offsets for each side. A common use for this is Preform sidewall inspections, where there is a dark area on either side of the preform in cameras one and three. With Custom 2 Sided Polygon, you could create the region to ignore that dark area.

### Region Width

(Used with Fit to Circle, Ribbon, and Loop) Specify how many pixels wide the region should be.

### Edge Offset

Specify how many pixels away from the found registration points the Adaptive Region should be.

### Region Offset Side 2

(Used with Custom 2 Sided Polygon) Create a different offset for one side of the part. This is normally used for Preform sidewall inspections.

### Ribbon/Loop Offset Style

(Used with Ribbon and Loop) **Distance Offset** works best with small offsets. **Proportional Scaling** works better with large offsets and keeps the shape nicely.

---

## Enhancements

Enhancements are used to alter images for the purpose of better defect detection, or for making certain features stand out. They are applied to any region type and you can add as many as needed to a region.

Notes:

- The unwrapped image (displayed while you are editing an inspection) shows the effect of the enhancement. You will not see any difference in the main image.
- Enhancements are added prior to inspections
- The order in which you place enhancements is important. The effect of most enhancements is cumulative, except for Color Distance and Color Extraction. Color Distance and Color Extraction work independently of other enhancements.
- To determine the best enhancement for your inspection, it may take some experimentation. Use the enhancement that brings out the defects or features best for your part.

### ➤ *To add an enhancement:*

1. Make sure at least one **region** (see "**Regions of Interest (ROI)**" on page 192) is placed on the image.
2. Right-click over the inspection tree and select Insert or Add > Enhancement.
3. Choose the desired enhancement from the menu.

The available enhancements are:

- **Subtract Bias** (on page 204)
- **Clipping** (on page 204)
- **Stretch Grayshades** (on page 205)
- **Binary** (on page 207)
- **Gamma Correction** (on page 208)
- **Grow Dark Areas** (on page 209)
- **Grow Light Areas** (on page 210)
- **Absolute Difference** (on page 210)
- **Color Distance** (on page 211)
- **Color Extraction** (on page 213)

❖ *Note: Your system (and this book) may show only those items that apply to your application.*

## Subtract Bias

Subtract Bias is a simple value subtraction across the entire region. Subtract the given value from all pixels in the region. The example below shows the result (bottom image) of subtracting a gray level of 80 from the top image.

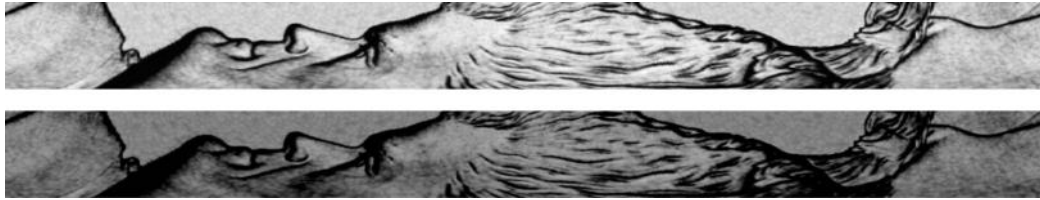

### ➤ To add a Subtract Bias enhancement:

1. Make sure at least one region is placed in the inspection tree.
2. Right-click on the item you just added.
3. From the Inspection menu, select Add > Enhancement > Subtract Bias. The enhancement is added to the inspection tree. Re-name the inspection to something more meaningful to you.
4. The Subtract Bias menu is displayed and the region is shown on the image. (The menu is described below) Adjust the parameters as necessary.

### Subtract Bias menu

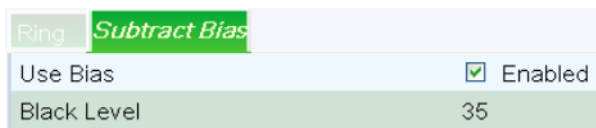

#### Use Bias

Enable the enhancement.

#### Black Level

Set the gray level value to subtract from the original value of each pixel in the region of interest.

## Clipping

Clipping is used to change gray shades to a specified value. It allows the system to ignore light reflections or normal grain in a part, to provide easier defect detection.

### ➤ To add a Clipping enhancement:

1. Make sure at least one region is placed in the inspection tree.
2. Right-click on the item you just added.
3. From the Inspection menu, select Add > Enhancement > Clipping. The enhancement is added to the inspection tree. Re-name it to something more meaningful to you.
4. The Clipping menu is displayed and the region is shown on the image. (The menu is described below) Adjust the parameters as necessary.

### Clipping menu



## Clipping mode

The available modes are as follows - also refer to the illustration below:

**Disabled** [item 1] – no clipping.

**Clip Black Level** [item 2] – set a dark gray shade value. A dark clipping value of 100 would take all pixels with gray levels of 0-99 and make them a gray level of 100.

**Clip White Level** [item 3] – set a light gray shade value. A light clipping value of 150 would take all pixels with gray levels of 151-255 and make them 150.

**Clip Black and White Levels** [item 4] – set both dark and light levels.

Below are grayscale plots of the area to illustrate the effects of clipping.

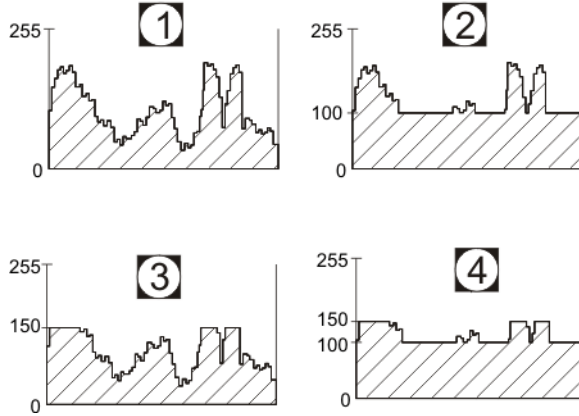

1	Original grayscale plot- Clipping Disabled
2	Clip Black Level - example uses 100 as black level
3	Clip White Level - example uses 150 as white level
4	Clip Black and White Levels - example uses 100 as black level and 150 as white level

You will see the effects of clipping in the Unwrapped Region of Interest, as shown below.

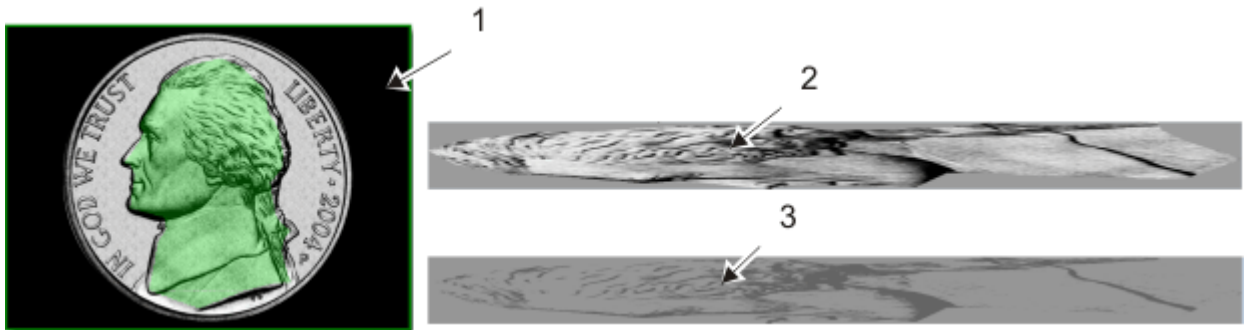

1	Region
2	Clipping Disabled
3	Clip Black and White Levels applied

## Stretch Grayshades

Stretch Grayshades is used when you want to make one feature stand out from the rest of the part. This technique works essentially how it sounds: it allows you to zoom in on a specific range of gray shades and stretch them to the full 0 - 255 range. You will see the effects of stretching gray shades in the Unwrapped Region of Interest.

### ➤ *To add a Stretch Grayshades enhancement:*

1. Make sure at least one region is placed in the inspection tree.
2. Right-click on the item you just added.
3. From the Inspection menu, select Add > Enhancement > Stretch Grayshades. The enhancement is added to the inspection tree. Re-name it to something more meaningful to you.
4. The Stretch Grayshades Menu is displayed and the region is shown on the image. (The menu is described below) Adjust the parameters as necessary.



### Stretch Grayshades

Enable the enhancement.

### Stretch Technique

Zoom in on any range of gray shades.

**Use Min/Max of Region** - the system uses the lowest gray shade found and the highest gray shade found, and stretches that range from 0 to 255.

**Use Grayshade Percentiles** - Specify lower and upper values in the Shades of Interest box in terms of percentage of pixels. The system counts the number of pixels of each gray shade and puts them into bins. An example is when 29-65 is used for Shades of Interest. The system determines (a) the gray shade where 29% of the pixels fall, and (b) the gray shade where 65% of the pixels fall. The system then takes the pixels at gray shades (a) and (b) and sets them to 0 and 255. The gray shades in between (a) and (b) are stretched from 1-254.

**Use Absolute Grayshades** - Specify lower and upper values in the Shades of Interest box. The system sets all pixels at or below the lower specified value to black, pixels at or above the higher specified value to white, and the values in between are stretched from grayshades 1 to 254.

### Shades of Interest

Define the gray shade range that you want to stretch. Adjust so that the desired feature stands out in the image.

## Stretch Grayshades example

In the example below, we use the mold line as a reference point. We want that mold line to stand out, so we use Stretch Grayshades.

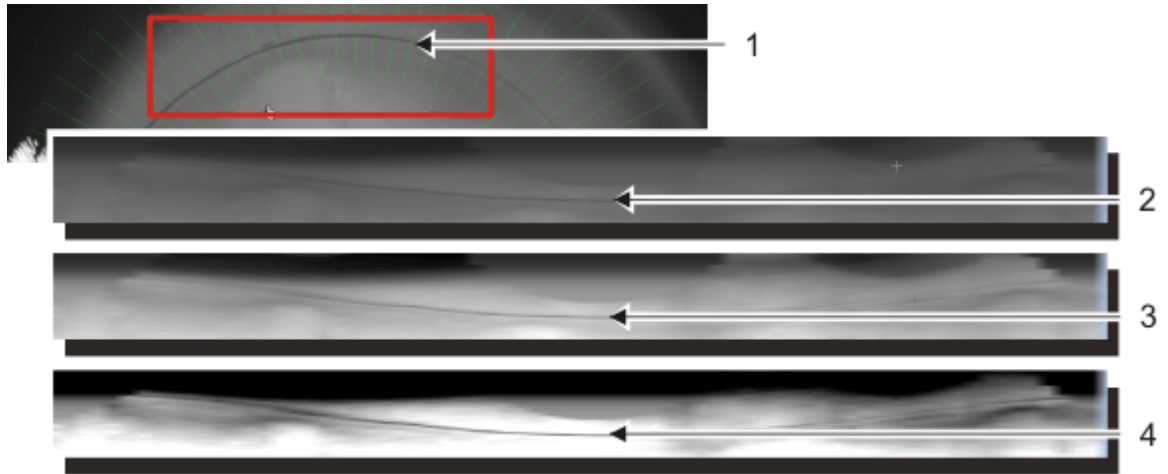

1	Original image
2	Unwrapped region of interest with no enhancement
3	Unwrapped region of interest with Use Min/Max of Region applied
4	Unwrapped region of interest with Use Grayshade Percentiles and Shades of Interest applied

## Binary

This enhancement makes all pixels at or above a threshold white, and makes all pixels at or below the threshold black. This can help certain features to stand out. An example of a Binary enhancement is shown below.

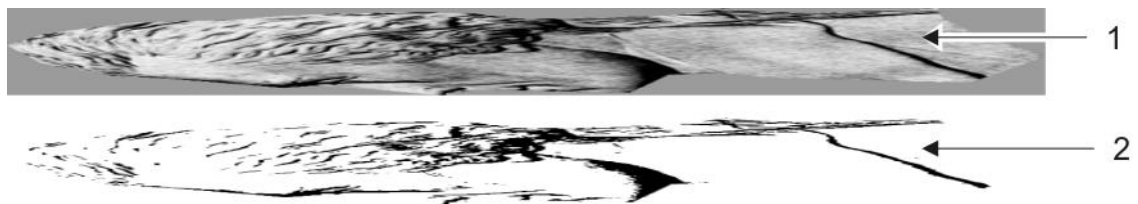

1	Unwrapped region of interest with no enhancement
2	Unwrapped region of interest with Binary Enhancement applied

### ➤ To add a Binary Enhancement:

1. Make sure at least one region is placed in the inspection tree.
2. Right-click on the item you just added.
3. From the Inspection menu, select Add > Enhancement > Binary. The enhancement is added to the inspection tree. Re-name it to something more meaningful to you.
4. The Enhancements menu is displayed and the region is shown on the image. (The menu is described below) Adjust the parameters as necessary.

## Binary enhancement menu

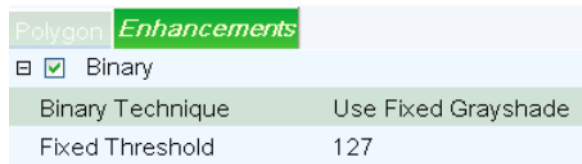

Use the technique and threshold that best suits your application.

### Binary Technique

Choose between Fixed Grayshade and Adaptive Grayshade. Set the related threshold as described below.

### Adaptive Threshold

The system computes the ambient level for the region. Set Adaptive Threshold to the percentage of pixels to use in the region. This is similar to the Peak Percentile technique used in the **Ambient** (on page 251) inspection.

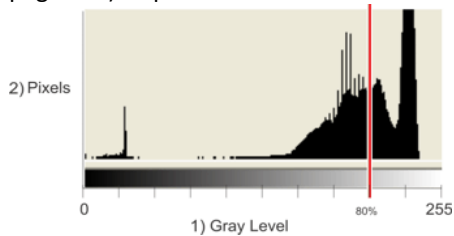

1	Gray level - choose a percentage
2	Pixels in the histogram of the image

### Fixed Threshold

The system uses the number you enter. All pixels at or below the threshold will be turned black. All pixels at or above the threshold will be turned white.

## Gamma Correction

Gamma Correction lets you reveal detail in a low-contrast image without significantly affecting the shadows or highlights. The example below shows the results of the Gamma Correction enhancement applied.

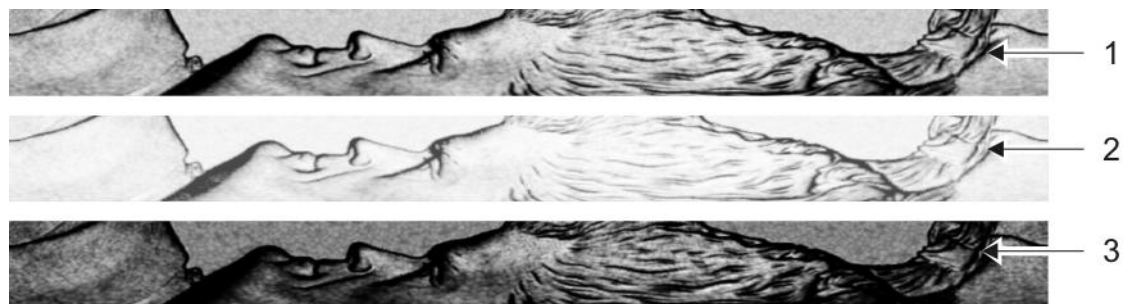

1	Original image
2	Decreased contrast - Gamma value less than one
3	Increased contrast - Gamma value greater than one

➤ **To add a Gamma Correction enhancement:**

1. Make sure at least one region is placed in the inspection tree.
2. Right-click on the item you just added.
3. From the Inspection menu, select Add > Enhancement > Gamma Correction. The enhancement is added to the inspection tree. Re-name it to something more meaningful to you.
4. The Gamma Correction menu is displayed and the region is shown on the image. (The menu is described below) Adjust the parameters as necessary.

### Gamma Correction menu

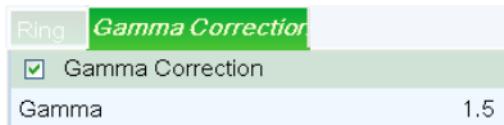

#### Gamma Correction

Enable the enhancement.

#### Gamma

Change the contrast of the image. Values less than one decrease contrast, and values greater than one increase contrast.

### Grow Dark Areas

This enhancement will grow the dark areas of the region. This can be used to remove reflections, or shrink bright spots on the image. The example below shows how Grow Dark Areas enhances the image.

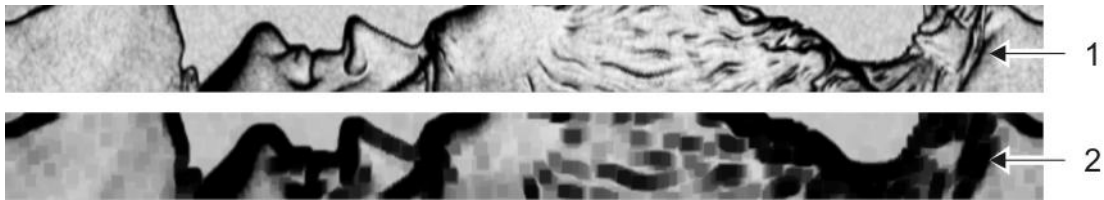

1	Normal image
2	Image with Grow Dark Areas applied

➤ **To add a Grow Dark Areas enhancement:**

1. Make sure at least one region is placed in the inspection tree.
2. Right-click on the item you just added.
3. From the Inspection menu, select Add > Enhancement > Grow Dark Areas. The enhancement is added to the inspection tree. Re-name it to something more meaningful to you.
4. The Grow Dark Areas menu is displayed and the region is shown on the image. (The menu is described below). Adjust the parameters as necessary.

### Enhancements menu



### Grow Dark Areas

Enable the enhancement.

### Growth Rate

Increase this value to grow the areas more.

### Max. Shade Delta

Specify the largest gray shade difference that can be applied to a pixel during area growth. If this value is set to zero, then the resulting pixel can be set to any value.

## Grow Light Areas

Grow Light Areas is the opposite of the Grow Dark Areas enhancement. Small dark defects can be blurred out and therefore ignored. The example below shows how Grow Light Areas enhances the image

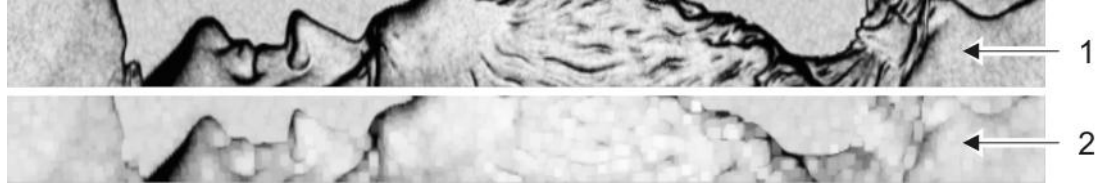

1	Normal image
2	Image with Grow Light Areas enhancement applied

### ➤ To add a Grow Light Areas enhancement:

1. Make sure at least one region is placed in the inspection tree.
2. Right-click on the item you just added.
3. From the Inspection menu, select Add > Enhancement > Grow Light Areas. The enhancement is added to the inspection tree. Re-name it to something more meaningful to you.
4. The Grow Light Areas menu is displayed and the region is shown on the image. (The menu is described below) Adjust the parameters as necessary.

### Enhancements menu

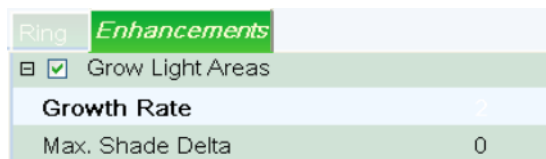

### Grow Light Areas

Enable the enhancement.

### Growth Rate

Increase this value to grow the areas more.

### Max. Shade Delta

Specify the largest gray shade difference that can be applied to a pixel during area growth. If this value is set to zero, then the resulting pixel can be set to any value.

## Absolute Difference

Absolute Difference will subtract a value from all of the gray shades in an image. The resulting gray shade value is an absolute value, so that value is always positive. For example, assume Absolute Difference is set at 100, and two original pixel values are 175 and 25. When the system subtracts 100 from each, the resulting values are both 75 [175 - 100 = 75, and 25 - 100 = 75] (using the absolute value).

The example below shows an Absolute Difference of 100 applied.

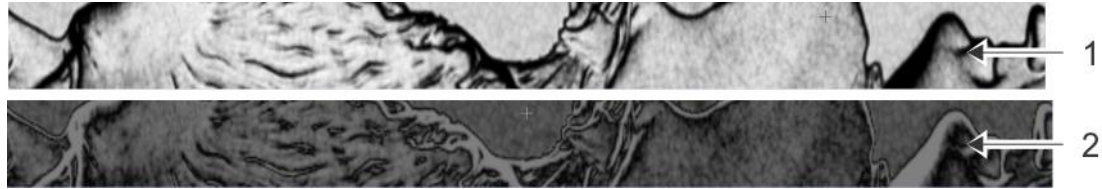

1	Normal image
2	Image with Absolute Difference enhancement applied

### ➤ To add an Absolute Difference enhancement:

1. Make sure at least one region is placed in the inspection tree.
2. Right-click on the item you just added.
3. From the Inspection menu, select Add > Enhancement > Absolute Difference. The enhancement is added to the inspection tree. Re-name it to something more meaningful to you.
4. The Enhancements menu is displayed and the region is shown on the image. (The menu is described below) Adjust the parameters as necessary. Experiment with values to enhance features you want to see more clearly on your part.

### Enhancements menu



#### Absolute Difference

Enable the enhancement.

#### Gray Level

The resulting pixel gray shade is the absolute difference between this value and the original pixel gray shade.

## Color Distance

Color Distance is used to provide more contrast between similar colors on an image to make certain defects or features stand out. This enhancement only applies to images produced by color cameras. It is similar to the **Absolute Difference** (on page 210) enhancement that is used for grayscale images.

❖ *Note: Color Distance works oppositely from Color Extraction. Experiment between the two enhancements to see which one works better for your application.*

Color Distance evaluates all pixels in the search region against the selected color and translates that value to a gray level. The closer a color is to the selected color, the darker the pixel. The further away a color is from the selected color, the lighter the pixel. This difference in pixel appearance is only displayed in the unwrapped region - not the full part image.

The example below shows a purple part against a blue belt. The region of interest is highlighted in the image for illustration purposes. Notice that, in the unwrapped region [item 1], the purple and blue colors are very similar when translated to grayscale, making it difficult to detect the part edges. We can apply a Color Distance enhancement to this image to make purple and blue stand out from each other, as shown in the unwrapped image [item 2].

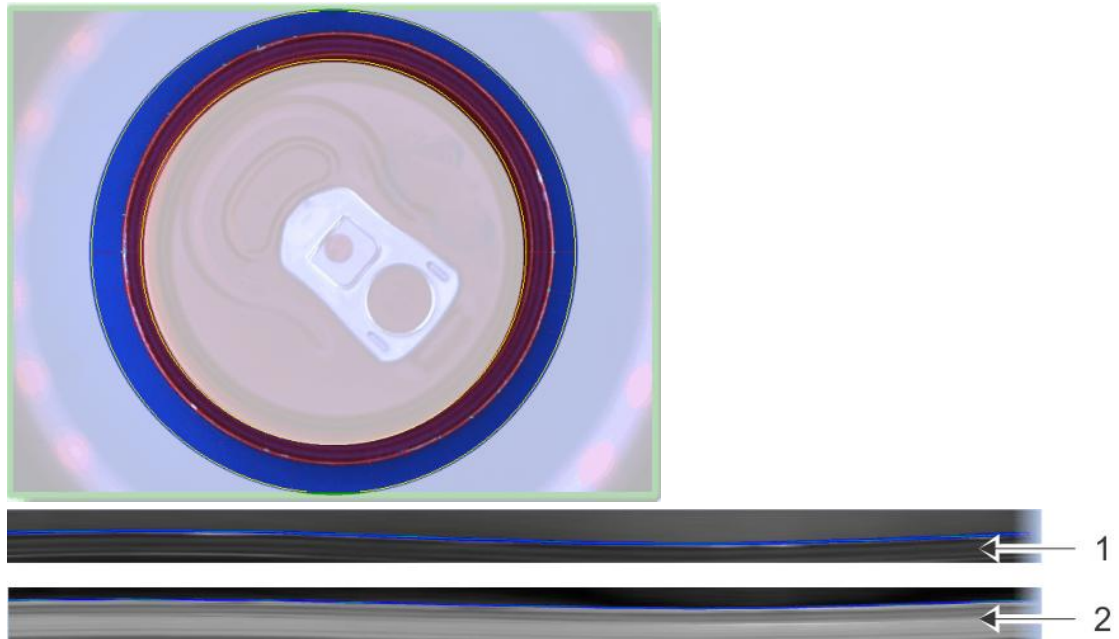

1	Normal image
2	Image with Color Distance enhancement applied

➤ **To add a Color Distance enhancement:**

1. Make sure at least one region is placed in the inspection tree.
2. Right-click in the inspection tree to see the Inspection menu.
3. From the Inspection menu, select Add > Enhancement > Color Distance. The enhancement is added to the inspection tree. Re-name it to something more meaningful to you.
4. The Color Distance menu is displayed and the region is shown on the image. (The menu is described below) Adjust the parameters as necessary. Experiment with values to enhance features you want to see more clearly on your part.

### Color Distance tab

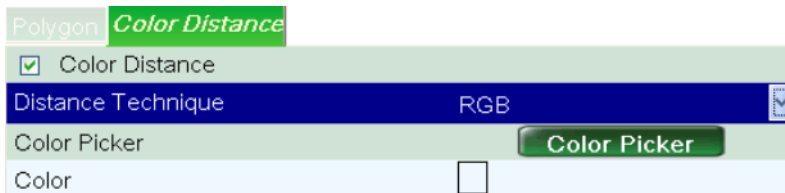

#### Color Distance

Enable the enhancement.

#### Distance Technique

Select how to determine the distance between two colors.

**RGB** - Uses the red, green, and blue components of a color.

**Delta E** - Not currently available.

## Color Picker

Choose the desired reference color.

### ➤ To use Color Picker:

1. Click the **Color Picker** button to begin selecting a color from the image. Click in the image again until the cursor becomes a cross-hair with an eye dropper.

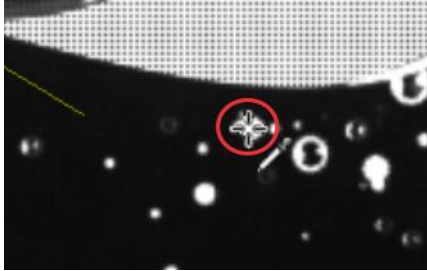

2. Using the center of the cross-hair, click in the image over the color you want to compare. The box next to Color in the menu displays your selected color.
3. When you have selected the desired color, click the **Color Picker** button again to complete the selection.

## Color

The box displays the selected color.

Click on this menu line to display a drop-down menu array of colors from which to choose. This can be used instead of using the Color Picker.

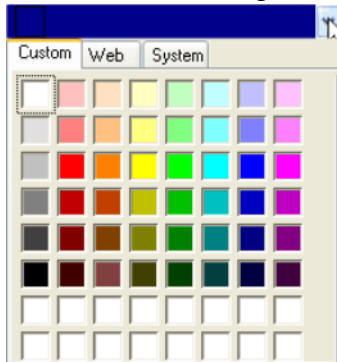

## Color Extraction

Color Extraction allows you to choose a color and then the system lightens all pixels with that color. This makes certain defects or features stand out. This enhancement only applies to images produced by color cameras.

❖ *Note: Color Distance works oppositely from Color Extraction. Experiment between the two enhancements to see which one works better for your application.*

When the Intellispec enhances the image, pixels containing the selected color will appear brighter. This difference in pixel appearance is only displayed in the unwrapped region - not the full part image. The color pixels are translated to grayscale values and then inspected. This is what you see in the unwrapped image.

The example below shows a purple part against a blue belt. The region of interest is highlighted in the image for illustration purposes. Notice that, in the unwrapped region [item 1], the purple and blue colors are very similar when translated to grayscale, making it difficult to detect the part edges. We can apply a Color Extraction enhancement to this image to make purple and blue stand out from each other, as shown in the unwrapped image [item 2].

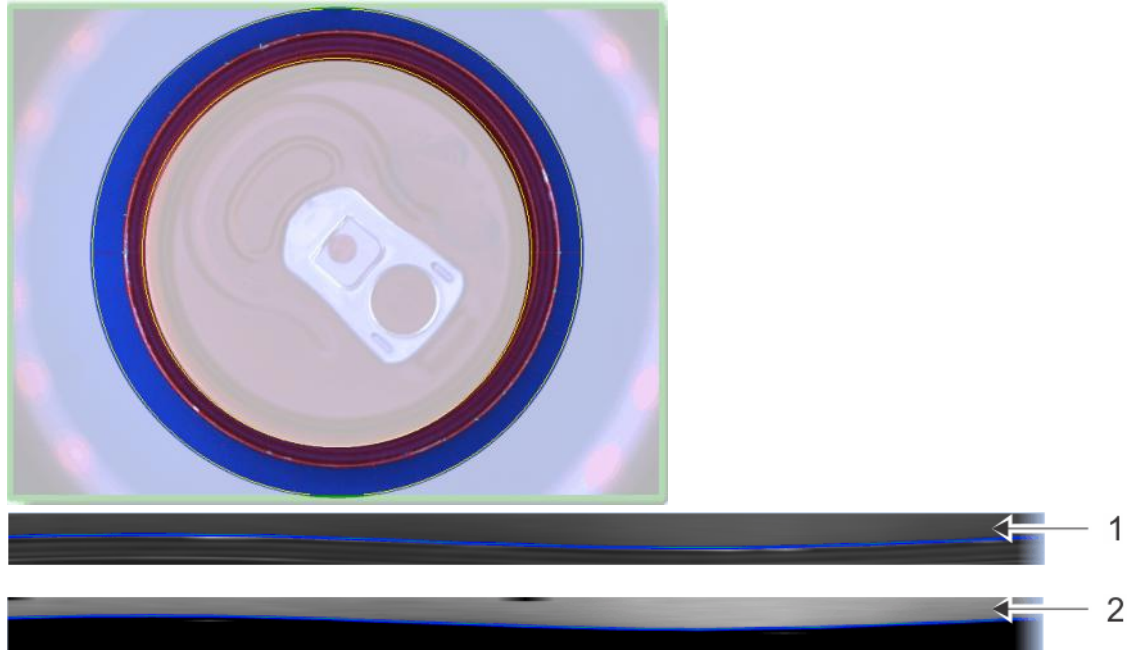

1	Normal image
2	Image with Color Extraction enhancement applied

➤ **To add a Color Extraction enhancement:**

1. Make sure at least one region is placed in the inspection tree.
2. Right-click in the inspection tree to see the Inspection menu.
3. From the Inspection menu, select Add > Enhancement > Color Extraction. The enhancement is added to the inspection tree. Re-name it to something more meaningful to you.
4. The Color Extraction menu is displayed and the region is shown on the image. (The menu is described below) Adjust the parameters as necessary. Experiment with values to enhance features you want to see more clearly on your part.

**Color Extraction tab**

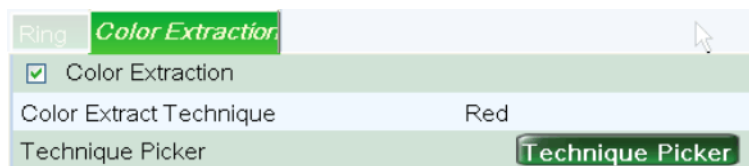

**Color Extraction**

Enable the enhancement. Use one of the following selections to choose the color you want to enhance.

### Color Extraction Technique

From the drop-down menu, select the color closest to the color you want to enhance. If you select a Raw color such as red, then the Intellispec enhances only the red pixels and ignores the green and blue elements of the image.

### Technique Picker

Choose a reference color from the image. The system will determine the closest color to the choices available. Note that the system has a limited set of color filters.

#### ➤ To use Color Picker:

1. Click the **Technique Picker** button to begin selecting a color from the image. Click in the image again until the cursor becomes a cross-hair with an eye dropper.

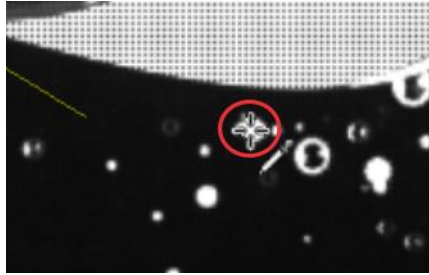

2. Using the center of the cross-hair, click in the image over the color you want to enhance. The menu item next to Color Extract Technique is updated to reflect the selected color.
3. When you have selected the desired color, click the **Technique Picker** button again to complete the selection.

---

## Registrations

A registration compensates for part movement by calculating the reference point on the part. All analyses follow a registration.

❖ *Note: you must first place a **Region of Interest** (see "**Regions of Interest (ROI)**" on page 192) where you want the Registration to take place.*

Available registrations include:

- **Feature** (on page 216)
- **Center of Mass** (on page 217)
- **Hough** (on page 219)
- **Radial Edge** (on page 223)
- **Centerline** (on page 225)
- **Finish Location** (on page 227)
- **Template Registration** (on page 231)
- Support Ring Registration

❖ *Note: Your system (and this book) may show only those items that apply to your application.*

### Hough vs. Radial Edge

This topic is intended to help you decide whether to use a Hough or Radial Edge registration for your round parts.

Use the registration that best fits your needs.

<b>Hough (on page 219)</b>	<b>Radial Edge (on page 223)</b>
Finds edges on not quite round parts	Finds edges on round parts

<b>Hough (on page 219)</b>	<b>Radial Edge (on page 223)</b>
Works on incomplete circular features	Works on complete circular features
Takes slightly more processing time	Faster

## Feature

This registration searches for the center of a specific feature that may not fall into a standard inspection shape. It looks for all the pixels within a specified gray shade range. Then you can choose whether to select the center from all the found features or just the largest feature. Alternately, you may restrict a feature size to determine the center; the found feature does not need to be the largest feature. It also allows you to count all the found features and reject the part if there are too many or too few. This can work on any region type.

*Series IV users: this is similar to Blob Registration.*

The example below shows a Feature registration to find the largest feature. The center of the largest feature is used as the registration point.

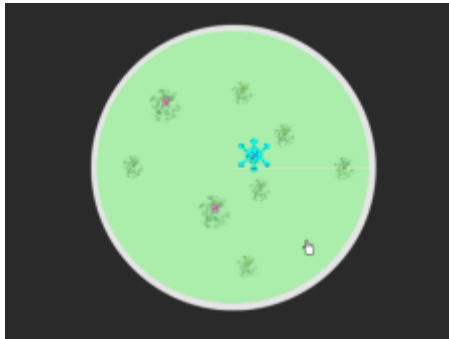

### ➤ To add a Feature Registration:

1. Make sure at least one region of interest has been added to the inspection tree.
2. Right-click on the item you just added.
3. From the Inspection menu, select Add > Registration > Feature. The Feature registration is added to the inspection tree. Re-name it to something more meaningful to you.
4. The Feature Menu is displayed and the region is shown on the image. (The menu is described below) Adjust the placement of the region and parameters as necessary.

### Feature menu

Ring	<b>Feature</b>
Center Detection	Use All Features
Feature Gray Scale	30 .. 100
Feature Size	5 .. 307200
Show Features	<input type="checkbox"/> Enabled
<input checked="" type="checkbox"/> Check Feature Area	
<input type="checkbox"/> Allowed Area	1000 - 1000 - 3000
Nominal	1000
Learn Nominal Area	<b>Learn</b>
<input type="checkbox"/> Check Feature Count	

### Center Detection

Choose whether to use the largest feature found, or all features.

### Feature Gray Scale

Set the range of gray shades of the feature you want to locate.

### Feature Size

Set the allowable size of the feature you want to locate.

### Show Features

Highlight the found features on the image.

### Check Feature Area

Check the area of the feature to see that it is within the specified tolerance.

### Allowed Area

[only available if Check Feature Area is enabled] The tolerance (in pixel area) of the feature you want to locate.

### Nominal

The expected area size. This number is populated when you press the **Learn** button.

### Learn Nominal Area

Click the **Learn** button to automatically learn the area.

### Check Feature Count

Check to see that the correct number of features is found.

## Center of Mass

Center of Mass is a simple edge center routine that will take the average of all found edges and use that as the center position. This can work on any region type.

❖ *Tip: Center of Mass can be used to find edges before an **Adaptive Region** (on page 200) to assist in locating the adapted region.*

An example of a Center of Mass registration is shown below. This registration works with almost any shape. The center of the part is marked with a large magenta "X."

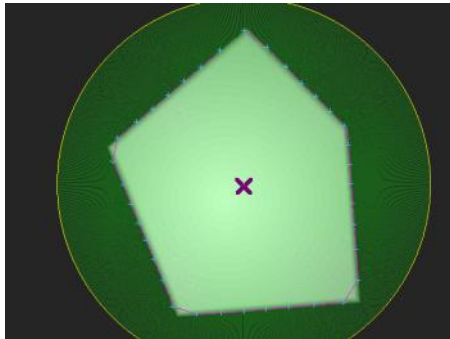

❖ *Note: the center is computed from all found edges. If bad edges are found from a defective part, those edges would be used in the center computation.*

### ➤ *To add a Center of Mass registration:*

1. Make sure a Region of Interest has been added to the inspection tree. This inspection will work with any region type.
2. Right-click on the item you just added.
3. From the Inspection menu, select Add > Registration > Center of Mass. The registration is added to the inspection tree. Re-name it to something more meaningful to you.
4. The Center of Mass menu is displayed and the region is shown on the image. (The menu is described below) Adjust the placement of the region and parameters as necessary.

➤ **To set up the Center of Mass registration:**

1. Make sure the region surrounds the feature that you want to locate.
2. Go to the Edge Location menu and select an **Edge Polarity**. If you are searching for a light edge against a dark background, choose Dark to Light.
3. Go back to the Center of Mass menu and select a **Center Technique**.
4. If necessary, change the **Search Direction** (check the Flipped box) to make the search vectors go in the opposite direction.
5. Adjust other parameters as necessary. The menu is described below.

## Center of Mass menu

Ring region	<b>Center of Mass</b>	Edge Location
Center Technique	Center of Mass	
Search Vector Count	36	
Search Direction	<input checked="" type="checkbox"/> Flipped	
Region Extraction	Read Radially	
▢ Diagnostics		
Show Edges	<input checked="" type="checkbox"/> Enabled	
▢ Reject Limits		
 Qualifying Percent Limits	25.0 .. 50.0	
▢ Area Settings		

### Center Technique

Choose the best technique to find the center.

**Center of Mass** - Find the center of mass of the total area enclosed by all edges. In most cases, this is the more accurate technique, but it may fail if the part is shaped irregularly, or if you are trying to find edges on a linear feature.

**Average of Edges** - Use for linear features or if the Center of Mass technique does not work for your part. This technique finds the average location of all individual edges. Average of Edges works better for ribbon types of regions.

### Search Vector Count

Set the number of search vectors to locate the feature on the container. More vectors provide a more accurate search, but also take more processing time.

### Search Direction

Change the search to the opposite direction.

### Region Extraction

Choose how the Intellispec should read the information from the region. This usually depends on the shape of your region. In this inspection, only Read Radially is used. The data is extracted in a radial direction as shown in the illustration below.

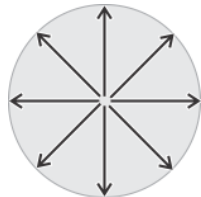

### Show Edges

Show the found edges on the image.

### Qualifying Percent Limits

The percentage of edges that must be part of the target circle. If there are not enough found edges on the target circle, this registration will fail. This can be set lower if you expect large changes in sample size (less sensitive). It can be set higher if the size of your product should not vary (more sensitive).

### Area Settings

Click the **Learn** button to determine the nominal area (in pixels) for your part.

#### Area Range

Define the acceptable deviation (in pixels) from the normal area of the region. You may also adjust the values on the Retro-Spec graph.

#### Nominal

The expected area size. This number is populated when you press the **Learn** button.

#### Learn Nominal Area

Click the **Learn** button to automatically learn the area.

### Edge Location menu

This menu determines what kind of edges the system should look for.

Ring region	Center of Mass	Edge Location
Edge Polarity		Either
Edge Gradient		15 .. 30
Edge Delta		2
Edge Size		2
Use Subpixel		<input type="checkbox"/> Enabled

#### Edge Polarity

Choose the type of edge to search for – Light to Dark, Dark to Light, or Either. For example, if the feature you want to find is very bright, choose Dark to Light.

#### Edge Gradient

The minimum and maximum difference in gray shades, between two pixels, to be considered an edge.

#### Edge Delta

The distance between pixels being compared when seeking an edge. A higher Delta value is more sensitive because it finds more edges.

#### Edge Size

Indicates how many pixels in a row to compare (1 to 1, 2 to 2, etc.). The larger the Edge Size, the stronger the edge will need to be. This parameter acts like a filter that looks at a length in pixels before and after the edge.

#### Use Subpixel

Finds edges based on their subpixel location, rather than rounding off to the nearest pixel. This gives greater centering accuracy.

## Hough

This registration locates a circular feature within an image and computes the center point of that feature. It also works with features that are not quite round. An important strength of this registration is that the feature you wish to find does not need to fit completely within the camera image. As long as a good portion of the feature can be found within the image, the computed center point is accurate. It also works well if the feature you wish to find is not clearly defined for 360 degrees.

❖ *Note: Hough registration only works with a **Ring region** (on page 193).*

Hough registration locates edges on the desired feature and computes the best center position based on these edges.

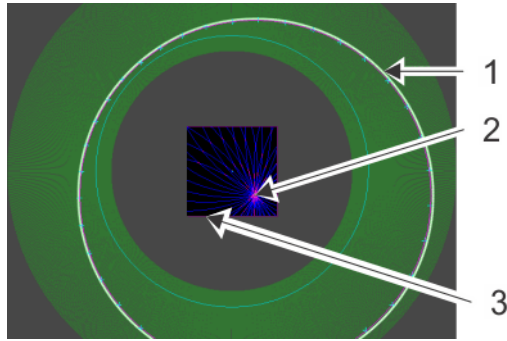

1	Feature (white circle) that we are searching for. This feature is partially outside of the camera view.
2	Found center of the feature
3	Bounding rectangle. The center must be found within the rectangle.

➤ **To add a Hough registration:**

1. Make sure a **Ring Region** (on page 193) of Interest has been added to the inspection tree.
2. Right-click on the item you just added.
3. From the Inspection menu, select Add > Registration > Hough. The registration is added to the inspection tree. Re-name it to something more meaningful to you.
4. The Hough menu is displayed and the region is shown on the image. (The menu is described below) Adjust the placement of the region and parameters as necessary.

➤ **To set up the Hough registration:**

1. Make sure the Ring region surrounds the feature that you want to locate. Adjust the ring with the parameters in the Ring menu (or the Region Editor on the image) if necessary.
2. In the Hough menu select a **Search Direction**. Flipped means that the vectors search from an outer to inner direction. If Flipped is unchecked, then the vectors search from an inner to outer direction.
3. Go to the Edge Location menu and select an **Edge Polarity**. If searching for a light edge against a dark background, choose Dark to Light.
4. Go to the Target Circle menu and click **Learn**. If the Edge Location parameters are set correctly, the system will automatically detect the proper target radius size. The system uses this radius to compute the center. You may need to adjust the parameters in the Hough, Target Circle, and Edge Location menus to find the desired feature accurately. These menus are discussed next.

## Hough menu

T	Edge Location	Stretch Grayshade	Hough	Target Circle
	Search Vector Count		203	
	Search Direction		<input checked="" type="checkbox"/> Flipped	
	<input checked="" type="checkbox"/> Bounding Rectangle		128W x 128H @(256,176)	
	Search Resolution		3	
	Region Extraction		Read Radially	
	<input type="checkbox"/> Diagnostics			
	<b>Show Edges</b>		<input type="checkbox"/> Enabled	
	<input type="checkbox"/> Reject Limits			
	<input checked="" type="checkbox"/> Minimum Center Strength		19	
	<b>Show Hough Graphics</b>		<input checked="" type="checkbox"/> Enabled	

### Search Vector Count

Set the number of search vectors to locate the feature on the container. More vectors provide a more accurate search, but also take more processing time.

### Search Direction

Change the search to the opposite direction.

❖ *Tip: if you flip the search direction, go back to the Target Circle menu and press Learn to re-learn the target radius size.*

### Bounding Rectangle

Adjust the size of the area where you would expect the center of the feature to be found, even with slight movement of parts in the camera's field of view. The system uses only this area to compute the center. If the computed center falls outside of this bounding area, the registration fails. Use **Height** and **Width** to adjust the number of pixels to create the size of the rectangle.

❖ *Note: larger sized Bounding Rectangles take more processing time.*

### Search Resolution

The area (in pixels) within the bounding rectangle where the center should be computed. A larger resolution allows a larger area. This allows the system to more accurately locate the center on parts that are not perfectly round.

### Region Extraction

Choose how the Intellispec should read the information from the region. This usually depends on the shape of your region. In this inspection, only Read Radially is used. The data is extracted in a radial direction as shown in the illustration below.

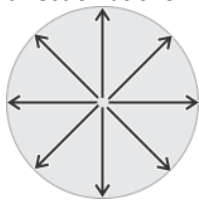

### Show Edges

Show the found edges on the image.

### Minimum Center Strength

The minimum strength, or quality, you require for the circle fit. When the quality of the fit is less than this value, the registration fails.

### Show Hough Graphics

Display the bounding rectangle and search graphics on the image.

## Target Circle menu

Edge Location			
True Center ROI	Stretch Grayshade	Hough	Target Circle
Target Radius	252		
Learn	<input type="button" value="Learn"/>		
Adapting Target Radius	<input checked="" type="checkbox"/> Enabled		
Adaptation Range	3		

❖ *Tip: to quickly set the Target Circle, click the Learn button. You could adjust the other parameters as necessary.*

### Target Radius

The size of the feature you want to find. This is automatically computed by using the Learn process.

### Learn button

Using the Edge Location settings, the system automatically sets the Target Radius size.

### Adapting Target Radius

When this is enabled, the system automatically figures out the best fit for the target radius, within the inner and outer radius of the region.

❖ *Note: Increasing Adaptation Range increases accuracy, but it also increases inspection time.*

### Adaptation Range

When Adapting Target Radius is used, this range limits the number of pixels that the target radius can move in either direction.

## Edge Location menu

True Center ROI	Stretch Grayshade	Hough	Target Circle
<b>Edge Location</b>			
Edge Polarity	Light-to-Dark		
Edge Gradient	0 .. 25		
Edge Delta	3		
Edge Size	1		
Use Subpixel	<input type="checkbox"/> Enabled		

### Edge Polarity

Choose the type of edge to search for – Light to Dark, Dark to Light, or Either. For example, if the feature you want to find is very bright, choose Dark to Light.

### Edge Gradient

The minimum and maximum difference in gray shades, between two pixels, to be considered an edge.

### Edge Delta

The distance between pixels being compared when seeking an edge. A higher Delta value is more sensitive because it finds more edges.

### Edge Size

Indicates how many pixels in a row to compare (1 to 1, 2 to 2, etc.). The larger the Edge Size, the stronger the edge will need to be. This parameter acts like a filter that looks at a length in pixels before and after the edge.

### Use Subpixel

Finds edges based on their subpixel location, rather than rounding off to the nearest pixel. This gives greater centering accuracy.

## Radial Edge

Radial Edge registration is good for circular parts that have a distinct edge either on the inside or outside of the part. This only works with a Ring region. Place the Ring region where you would expect the edges of the part to fall. The system searches for edges from the inner to the outer radius (or outer to inner radius), searching for a transition from light to dark or dark to light pixels. Each search vector tries to detect an edge, using the Edge Location parameters. Found edges are marked with a cyan or red '+' for pass or fail status.



### ➤ To add a Radial Edge registration:

1. Make sure a **Ring Region** (on page 193) has been added to the inspection tree.
2. Right-click on the item you just added.
3. From the Inspection menu, select Add > Registration > Radial Edge. The Radial Edge registration is added to the inspection tree. Re-name it to something more meaningful to you.
4. The Radial Edge Menu is displayed and the region is shown on the image. (The menu is described below) Adjust the placement of the region and parameters as necessary.

### ➤ To set up the Radial Edge registration:

1. Make sure the Ring region surrounds the feature that you want to locate. Adjust with the parameters in the Ring menu (or the Region Editor on the image) if necessary.
2. In the Radial Edge menu select a **Search Direction**. Flipped means that the vectors search from an outer to inner direction. If Flipped is unchecked, then the vectors search from an inner to outer direction.
3. Go to the Edge Location menu and select an **Edge Polarity**. If searching for a light edge against a dark background, choose Dark to Light.
4. Go to the Target Circle menu and click **Learn**. If the Edge parameters are set correctly, the system will automatically detect the proper target radius size. The system uses this radius to compute the center. You may need to adjust the parameters in the Radial Edge, Target Circle, and Edge Location menus to find the desired feature accurately. These menus are discussed next.

## Radial Edge menu

Ring	Radial Edge	Target Circle	Edge Location
	Search Vector Count		36
	Search Direction		<input checked="" type="checkbox"/> Flipped
	Radial Tolerance		5
<input type="checkbox"/>	Diagnostics		
	Show Edges		<input checked="" type="checkbox"/> Enabled
<input type="checkbox"/>	Reject Limits		
<input checked="" type="checkbox"/>	Qualifying Percent Limits		25.0 .. 50.0

### Search Vector Count

Set the number of search vectors to locate the feature on the container. More vectors provide a more accurate search, but also take more processing time.

### Search Direction

Change the search to the opposite direction.

### Radial Tolerance

The number of pixels in either direction of the target circle that the system will consider an edge (that is, the size range allowed for the part). A radial tolerance of two allows a four pixel wide area in which the edge of the part may fall.

### Show Edges

Show the found edges on the image.

### Qualifying Percent Limits

The percentage of edges that must be part of the target circle. If there are not enough found edges on the target circle, this registration will fail. This can be set lower if you expect large changes in sample size (less sensitive). It can be set higher if the size of your product should not vary (more sensitive).

## Target Circle menu

Ring	Radial Edge	<b>Target Circle</b>	Edge Location
Target Radius	100		
Learn	<b>Learn</b>		
Adapting Target Radius	<input type="checkbox"/> Enabled		

### Target Radius

The size of the feature you want to find. This is automatically computed by using the Learn process.

### Learn button

Using the Edge Location settings, the system automatically sets the Target Radius size.

### Adapting Target Radius

When this is enabled, the system automatically figures out the best fit for the target radius, within the inner and outer radius of the region.

## Edge Location menu

True Center ROI	Stretch Grayshade	Hough	Target Circle
<b>Edge Location</b>			
Edge Polarity	Light-to-Dark		
Edge Gradient	0 .. 25		
Edge Delta	3		
Edge Size	1		
Use Subpixel	<input type="checkbox"/> Enabled		

### Edge Polarity

Choose the type of edge to search for – Light to Dark, Dark to Light, or Either. For example, if the feature you want to find is very bright, choose Dark to Light.

### Edge Gradient

The minimum and maximum difference in gray shades, between two pixels, to be considered an edge.

### Edge Delta

The distance between pixels being compared when seeking an edge. A higher Delta value is more sensitive because it finds more edges.

### Edge Size

Indicates how many pixels in a row to compare (1 to 1, 2 to 2, etc.). The larger the Edge Size, the stronger the edge will need to be. This parameter acts like a filter that looks at a length in pixels before and after the edge.

## Use Subpixel

Finds edges based on their subpixel location, rather than rounding off to the nearest pixel. This gives greater centering accuracy.

## Centerline

Centerline Registration finds the sides of a container and determines the center line between them. It also computes an orientation of the container. This registration uses the mirrored polygon ribbon region. With Centerline registration, you can determine the orientation of a feature and compare it to the orientation of the entire part. You can also check the slope of the sides of the container, or check the overall shape of the container.

*Series IV users: this replaces Midline Orientation, and is similar to Shape Adapt Registration.*

- ❖ *Note: this registration requires a **Ribbon Region** (on page 196) using settings: Ribbon Style = Ribbon, and Mirror Ribbon = Enabled.*
- ❖ *Tip: you can use Centerline to determine Registration plus Orientation, or just Orientation.*

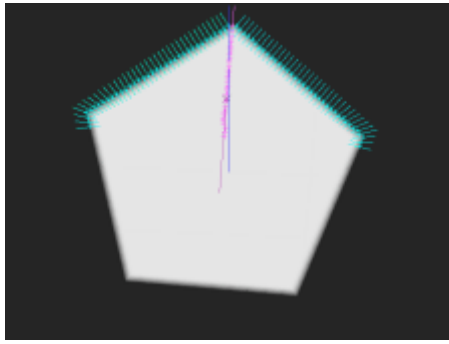

### ➤ To add a Centerline Registration:

1. Place a **Ribbon Region** (on page 196), using a mirrored ribbon.
2. Right-click in the inspection tree to see the Inspection menu.
3. From the Inspection menu, select Add > Registration > Centerline. The Centerline registration is added to the inspection tree. Re-name it to something more meaningful to you.
4. The Centerline Menu is displayed and the region is shown on the image. (The menu is described below) Adjust the placement of the region and parameters as necessary.

## Centerline menu

Ribbon	Centerline	Search Settings
Applied Results	Center and Orientation	
Setup Mode	Common Setup	
Search Vector Count	36	
Region Extraction	Read Radially	
Diagnostics		
Show Vectors	<input type="checkbox"/> Enabled	
Show Edges	<input checked="" type="checkbox"/> Enabled	
Show Alignment	<input checked="" type="checkbox"/> Enabled	
Shape Check		
Shape Limits	0.0° +360.0° / -360.0°	
Nominal	0.0°	
Shape Sensitivity	90	
Area Check		
Angle Check		

### Applied Results

This determines whether the found center and/or orientation are reported to inspections that follow the Centerline. Use Center and Orientation to report both to following inspections. Use Orientation to report only the orientation, but use a previously found center.

### Setup Mode

Use the same parameters to find both sides of the container (Common Setup), or set up the parameters differently for each side of the container (Individual Setup).

### Search Vector Count

Set the number of search vectors to locate the feature on the container. More vectors provide a more accurate search, but also take more processing time.

### Region Extraction

Choose how the Intellispec should read the information from the region. This usually depends on the shape of your region. In this inspection, only Read Radially is used. The data is extracted in a radial direction as shown in the illustration below.

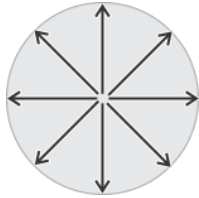

## Diagnostics

### Show Vectors

Show the search lines on the image.

### Show Edges

Show the found edges on the image.

### Show Alignment

Display the alignment of the current part with respect to the previous alignment.

## Shape Check

Check the angle of the sides of the container.

### Shape Limits

Set the angle limits for the container.

### Nominal

The ideal value for the shape of the container.

### Shape Sensitivity

Set the sensitivity for the straightness of the center line. 100 indicates that points must fall on a perfectly straight line (most sensitive). A setting of one indicates that points can fall anywhere (least sensitive). A value of 90 is good sensitivity in most cases.

## Area Check

Check the area of the points found. It is good for determining underblown and overblown bottles.

### Area Range

Define the acceptable deviation (in pixels) from the normal area of the region. You may also adjust the values on the Retro-Spec graph.

### Nominal

The expected area size. This number is populated when you press the **Learn** button.

### Learn Nominal Area

Click the **Learn** button to automatically learn the area.

## Angle Check

Check the orientation of a feature against the previous orientation. If an orientation inspection was not added to the part program, zero degrees is used. For example, this could be used to detect turned tabs on a converted end.

### Angle Limits

Set the angle tolerance for the feature.

### Nominal

The ideal orientation of the feature.

### Centerline Sensitivity

Set the orientation sensitivity. The range is from one to 100 with one being the least sensitive and 100 being the most sensitive. The value of 90 is good sensitivity in almost all cases.

## Search Settings menu

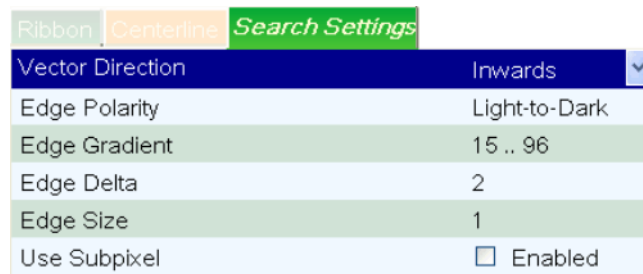

Ribbon	Centerline	Search Settings
Vector Direction	Inwards	▼
Edge Polarity	Light-to-Dark	
Edge Gradient	15 .. 96	
Edge Delta	2	
Edge Size	1	
Use Subpixel	<input type="checkbox"/> Enabled	

This menu specifies settings for the search vectors.

### Vector Direction

Specify which direction the vectors should search, with respect to the center.

### Edge Polarity

Choose the type of edge to search for – Light to Dark, Dark to Light, or Either. For example, if the feature you want to find is very bright, choose Dark to Light.

### Edge Gradient

The minimum and maximum difference in gray shades, between two pixels, to be considered an edge.

### Edge Delta

The distance between pixels being compared when seeking an edge. A higher Delta value is more sensitive because it finds more edges.

### Edge Size

Indicates how many pixels in a row to compare (1 to 1, 2 to 2, etc.). The larger the Edge Size, the stronger the edge will need to be. This parameter acts like a filter that looks at a length in pixels before and after the edge.

### Use Subpixel

Finds edges based on their subpixel location, rather than rounding off to the nearest pixel. This gives greater centering accuracy.

## Finish Location

Finish Location is used to locate the top corners of a bottle. It uses a ribbon region. Finish Location also determines part orientation, and passes on the orientation to subsequent inspections.

*Series IV users: Finish Location is similar to Finish Registration in Series IV*

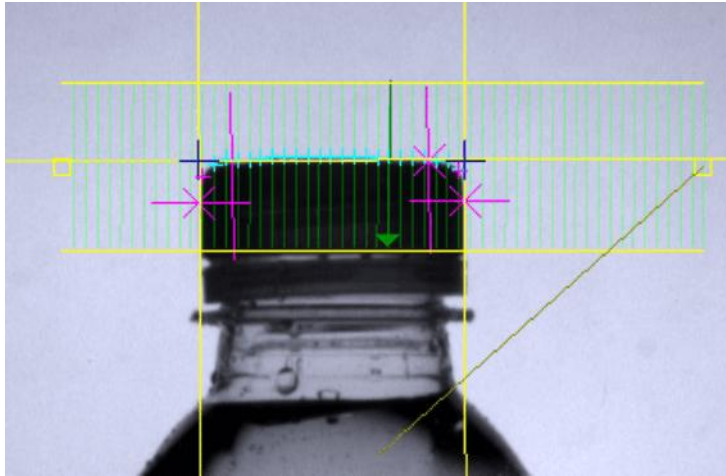

### ➤ To add a Finish Location registration:

1. Make sure a **Ribbon Region** (on page 196) of Interest has been added to the inspection tree. An example of region placement is shown below.

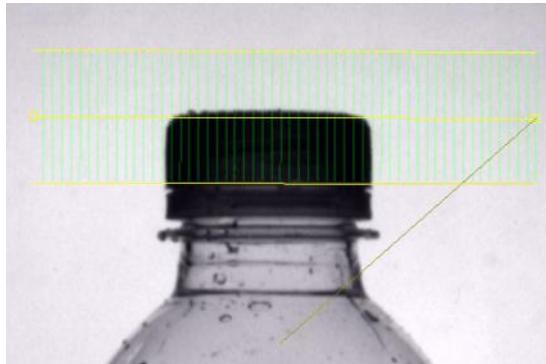

2. Right-click in the inspection tree to see the Inspection menu.
3. From the Inspection menu, select Add > Registration > Finish Location. The registration is added to the inspection tree. Re-name it to something more meaningful to you.
4. The Finish Location menus are displayed and the region is shown on the image. (The menus are described below) Adjust the placement of the region and parameters as necessary.

### Finish Location tab

Ribbon	Finish Location	Search	Corner	Diagnostics
	Search Vector Count			36
	Search Direction		<input checked="" type="checkbox"/>	Flipped
	Finish Settings			
	<input checked="" type="checkbox"/> Tilt Limits			0.0° +10.0° -10.0°
	Nominal			0.0°
	Region Extraction			Read Partially

### Search Vector Count

Set the number of search vectors to locate the feature on the container. More vectors provide a more accurate search, but also take more processing time.

### Search Direction

Change the search to the opposite direction.

## Finish Settings

### Tilt Limits

Set the allowed range of tilt of the part within the image.

### Nominal

The expected degree of tilt.

### Region Extraction

Choose how the Intellispec should read the information from the region. This usually depends on the shape of your region. In this inspection, only Read Radially is used. The data is extracted in a radial direction as shown in the illustration below.

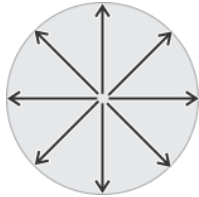

## Search tab

Ribbon	Finish Locatio	Search	Corner	Diagnostics
Edge Polarity				Either
Edge Gradient				15 .. 30
Edge Delta				2
Edge Size				2
Use Subpixel				<input type="checkbox"/> Enabled
Edge Thickness				1

### Edge Polarity

Choose the type of edge to search for – Light to Dark, Dark to Light, or Either. For example, if the feature you want to find is very bright, choose Dark to Light.

### Edge Gradient

The minimum and maximum difference in gray shades, between two pixels, to be considered an edge.

### Edge Delta

The distance between pixels being compared when seeking an edge. A higher Delta value is more sensitive because it finds more edges.

### Edge Size

Indicates how many pixels in a row to compare (1 to 1, 2 to 2, etc.). The larger the Edge Size, the stronger the edge will need to be. This parameter acts like a filter that looks at a length in pixels before and after the edge.

### Use Subpixel

Finds edges based on their subpixel location, rather than rounding off to the nearest pixel. This gives greater centering accuracy.

## Corner tab

Adjust these settings to best find the corner on your part.

❖ Note: Enable the **Show Corners** option in the Diagnostics tab to see the position of the vectors.

Ribbon	Finish Locatio	Search	Corner	Diagnostics
Corner Desensitization			10	
Top Vector: Side Shift			20	
Side Vector: Down Shift			20	
Side Vector: Side Shift			0	
Side Vector: Length			50	

### Corner Desensitization

Larger values are used to detect more rounded corners. This is used to prevent detection of false corners.

The illustration below shows the top and side vectors that search for the part. Note that your image may be rotated depending on application. Regardless of orientation, the top vectors search for the top of your part, and the side vectors search for the sides of your part.

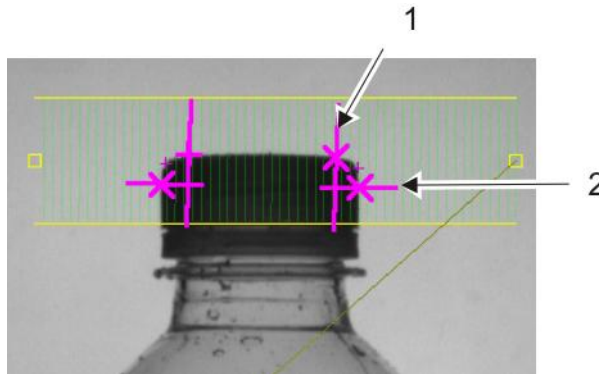

1	Top vector (perpendicular to the ribbon)
2	Side vector (parallel to the ribbon)

#### Top Vector: Side Shift

Move the top vectors closer or further away from the corner.

#### Side Vector: Down Shift

Move the side vectors closer or further away from the corner.

#### Side Vector: Side Shift

Move the side vectors closer to or further away from the midpoint of the cap or part.

#### Side Vector: Length

Increase or decrease the length of the side search vectors.

## Diagnostics tab

Ribbon	Finish Locatio	Search	Corner	Diagnostics
Show Vectors				<input type="checkbox"/> Enabled
Show Search Direction				<input checked="" type="checkbox"/> Enabled
Show Edges				<input checked="" type="checkbox"/> Enabled
Show Corners				<input checked="" type="checkbox"/> Enabled
Show Corner Search				<input type="checkbox"/> Enabled
Show Framing				<input type="checkbox"/> Enabled

### Show Vectors

Show the search lines on the image.

### Show Search Direction

Show the search direction of the vectors with an arrow.

### Show Edges

Show the found edges on the image.

### Show Corners

Display the location of the finish corners.

### Show Corner Search

Display the search used to find the corners. You must also enable 'Show Graphics' in the **Image Options** (on page 164) menu.

### Show Framing

Display the lines that show where the finish is located based on the projected corners.

## Template Registration

Template Registration is used to locate the center of a feature that is either irregularly shaped, or is located in a region with a lot of gray scale variation. Examples include rivets from converted ends, EZO ends, and rectangular bottles.

- ❖ *Notes: this registration may not perform well if the visual features are not consistent from part to part.*
- ❖ *If an orientation is needed, use a separate **Template Orientation** (on page 246) instead of the orientation built into this inspection, to save processing time, EXCEPT if you are inspecting a part with decoration on it. See the Template Registration menu description for more information.*

Series IV users: This is similar to Series IV Template Registration

### **Before adding the Template Registration:**

Choose Option 1 or Option 2 from the choices below.

- **Option 1: If your part's feature appears in an unpredictable location in the image, then use the Measure ROI method:**

Example: for this EZO closure, we are not sure where the rivet will appear in the image. We are using Measure ROI region.



1. Add a **Measure ROI** (on page 198) region of interest to the part program. This can be placed at the highest level in the inspection tree.

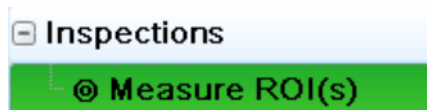

2. Leave Region Count at One Region.
3. In the Measure ROI menu, set the Center Offset X and Y to zero.

Measure ROI(s)	
Region Count	One Region
☐ Region 1	
Center Offset X	0
Center Offset Y	0
Region Width	630
Region Height	470
Region Angle	90.0

4. Place the inspection region over almost the entire region:
  - If you have a 640 x 480 image, then set Region Width and Region Height to 630 and 470, respectively. This allows a five pixel margin around the inspection window.
  - If you have a 1360 x 1024 image, then set Region Width and Region Height to 1350 x 1014, respectively. This allows a five pixel margin around the inspection window.
5. Click the OK button  to save changes and exit the menu.
6. Go to the section: "To add a Template Registration."

➤ **Option 2: If you know approximately where your part's feature might appear in the image, then use a Ring or other region method:**

Example: in this converted end rivet image, we know approximately where the rivet might appear. We are using a Ring region.

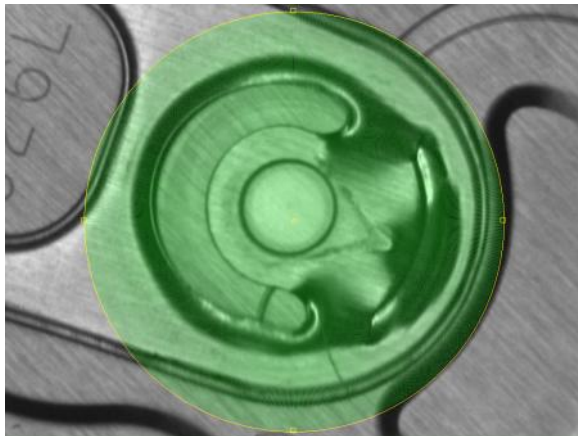

1. Add a Ring region (or other region) to the part program. Note: make this region as small as possible, but make sure that the desired feature is ALWAYS in the region of interest regardless of part movement. Using a smaller region saves inspection time.
2. Click the OK button  to save changes and exit the menu.
3. Add a Template Registration.



➤ **To add a Template Registration:**

1. Make sure a region has been added to the inspection tree, as described above in either Option 1 or Option 2.
2. Acquire about 100 images to get a good sample population of part images:
  - Put the lane online, long enough to acquire about 100 images. Take the lane offline.
  - **OR:** Use **Offline Imaging** (on page 137). Right-click the Sensor button to see the Sensor menu > select Offline Imaging > Immediate Mode **Run** button. Exit the Offline Imaging screen after acquiring about 100 images.
3. Right-click on the item you just added.

4. From the Inspection menu, select Add > Registration > Template Registration. The registration is added to the inspection tree. Re-name it to something more meaningful to you. The Template Registration menus are displayed and the region is shown on the image. (The menus are described below)
5. If your part does not have deco, then un-check the Perform Orientation box in the Template Registration menu. Then go to the section: "**To save a seed image.**"
6. If you are inspecting a part with deco, then leave the Perform Orientation box checked.
7. Go to the Settings menu and click the **Standard Settings** button.

Next, choose an image and save it as a seed image. A "seed" image is a sample image that the system uses when creating an average image for the template.

➤ **To save a seed image:**

1. From the Retro-Spec inspection screen, find an image that represents a regular part - not the best image, not the worst image, but a typical part image. Use the forward/ backward arrows  to scroll through the acquired images.
2. If necessary, adjust the region size and placement to cover an area where there is a repeatable and distinct grayscale pattern.
3. Go to the Template menu (described below) and click the **Save Seed** button. An on screen keyboard is displayed.
4. Name the seed image and click the OK button  to save. A Saved Template dialog box is displayed with the name and location of the saved template image.

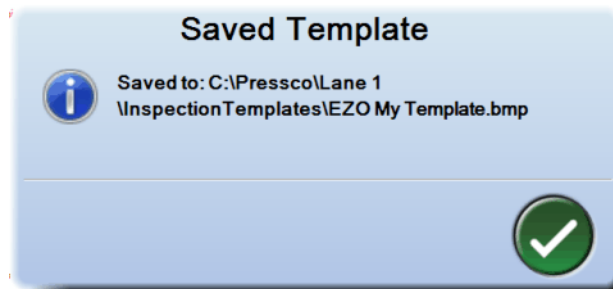

5. Click the OK button to close the message.
6. To verify that you have saved a good image, click the **View Template** button. The Template Image Viewer will display the seed image you saved. If you want to save a different image, select another image and click the Save Seed button.

**OPTIONAL:** Select a **Template Region type**. The system will look at a smaller portion of the region to save inspection time (In our example, we want to find just the rivet in the image).

❖ *Note: in MOST APPLICATIONS, you will use the entire inspection region rather than looking at only a portion of the region. Skip to the section "**To adjust the registration.**"*

➤ **To select a Template Region type:**

1. In the Template Region menu, select a Template Region type: either Ring Region or Polygon Region, depending on the feature you want to locate. In our example, we want to find a circle, so we choose Ring region. (The region types are discussed in the section titled "Template menu")
  - Notes about using Ring or Polygon region:
    - a) The registration does not perform an orientation when looking for this region. The feature used for the polygon or ring region must be located in the same place on each part.
    - b) Template Region is only used with a **seed** image. If you later use "Create Template," then the inspection uses the entire created prior to adding the Template Registration inspection. It ignores this ring or polygon region.
2. Click the **View Editor** button. The Template Image Viewer is displayed with the template image.

3. Click inside the region in the Template Image Viewer image to adjust its size and position. Use the yellow boxes as points to adjust the region. Moving one yellow box adjusts all four boxes, making the ring either larger or smaller. Wait while the system updates the image. An example is shown below.
  - Right-click in the Template Image Viewer to view the **Image Options** menu. Turn on or off options to change the region and use as needed.
  - If using a **Polygon Region**, the system will prompt you to click anywhere in the image to begin placing points. Keep clicking points in image to create the polygon. To close the polygon, click the first point again.
  - Remember that the center point is also a ring (if using a Ring Region). It can be adjusted to create a donut shaped region.

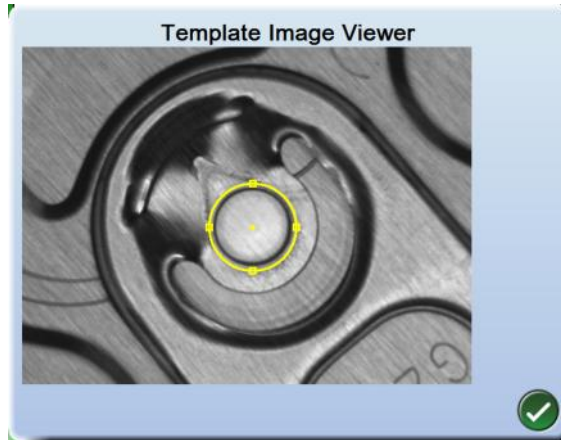



4. Click the OK button in the Template Image Viewer to save changes and exit.

Next, test the registration and adjust settings so that it will work on almost all part images. The menus are described below. If you set up a Template Region, then you will NOT use the Create Template section described below.

➤ **FOR MOST APPLICATIONS: To adjust the registration:**

1. In the Retro-Spec graph, or using the forward and backward arrows below the image, view all the



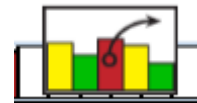

images in Data Set A. If necessary, use the  or  buttons to acquire more images. You want a range of part images that represent your production line. They do not have to be perfect images, but you should remove images of parts that should obviously be rejected.

2. Delete images of any parts that should not be part of the sample population:



- a) Click the Lock/ Move Parts button to unlock the data set.
  - b) Click the bar on the graph for any part you want to delete, then click the trash can icon to delete the part from the set.
  - c) For information about how to use the graph, see Retro-Spec Population View Graph.
  - d) Click the Lock/ Move Parts button again to lock it.
3. In the Template menu, click the **Create Template** button. This creates a template using all the data set images combined instead of using one image.
  4. (Optional) In the Settings menu, set Downsize Level at Level 2 (16 to 1). This will speed inspection time.

❖ *Note: Downsizing creates a slight pixel error. The more Downsizing used, the more pixel error is produced. We use Downsizing when Template Registration is being used as a coarse registration to locate a feature. We then add an additional registration such as Radial Edge or Hough to accurately find the center of the feature.*

5. In the Template Registration menu, adjust Registration Strength. This can be adjusted by the horizontal bar in the Retro-Spec graph. This will set pass/ fail limits for the registration.
6. Test the registration: put the lane online to acquire several images, then click the  or  buttons to update the Retro-Spec graph. Make sure that bad parts are failing, as indicated in the Retro-Spec graph (red bars). Take the lane offline. If you used the  to update the images, then click it again to stop updating the Retro-Spec graph.
7. Make adjustments to the registration as instructed by Pressco for your application. The menus are described below.
8. In applications such as our example, Template Registration is used as a coarse registration. Add another registration after the Template Registration, such as Radial Edge, to accurately locate the center of the feature.

## Template menu

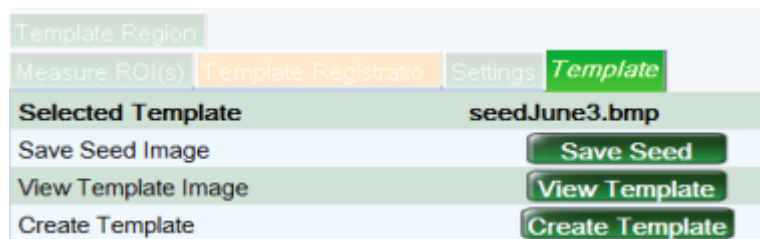

### Selected Template

Select any saved template from the drop-down menu. If no templates have been created, no drop-down menu is available.

### Save Template Image

Save the current image as a template.

### View Template Image

To verify that you have selected the correct template image, click the **View Template** button. A pop-up window displays the saved template image. An example is shown below.



❖ *Note: displaying the template image does not display it in the Intellispec image area.*

### Create Template

Use all the images in Data Set A to create an average image, starting with the seed image. For best results, delete all defective images, or images that you do not want as part of the template, from Data Set A.

## Template Region menu

Choose whether to use a single region for both the search region and the template region. Using multiple regions can speed up inspection time.

Ring	Template Registration	Settings	Template	Template Region
Template Region Type		Use Ring Region		
View Template Editor		<input type="button" value="View Editor"/>		
X		0		
Y		0		
Inner Radius		1		
Thickness		127		
Use Arcs		<input type="checkbox"/>	Enabled	

### Template Region Type

❖ *Note: most applications use Inspection Region. If you use **Ring** or **Polygon** region, then the system only uses a **seed** image as the template (not Data Set A, as is used when you click Create Template).*

Select the region to use for the template region.

- **Use Inspection Region** - Use the region of interest already set up prior to this inspection.
- **Use Ring Region** - Create a region smaller than the search region, to speed up inspection time.
- **Use Polygon Region** - Create a polygon region to use for the template instead of the search region, to speed up inspection time. When you choose this option, click the View Editor button to create the polygon. In the Template Image Viewer, create a polygon by clicking several points in the image. To complete the polygon, click the first point again.

❖ *Note: The following parameters are used only if Use Ring Region is selected for Template Region Type. View Template Editor is also used when Use Polygon Region is selected.*

### View Template Editor

To move the region, click the **View Editor** button. A pop-up window displays the saved template image with a region. Click in the image to move the region. Right-click in the viewer for more options. An example is shown below.

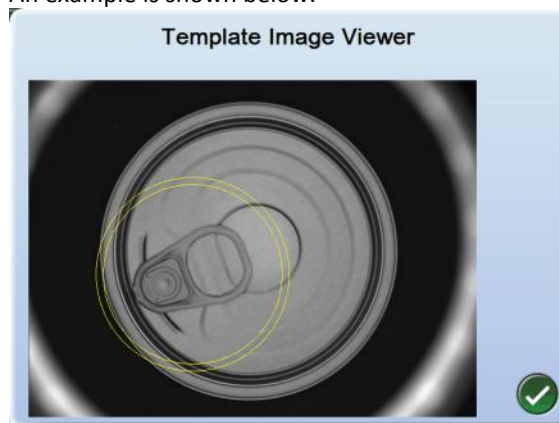

❖ *Note: the content in the image viewer does not display in the Retro-Spec image area.*

### X and Y

Enter the X and Y offset coordinates for the center of the region you want to establish as your template region. These values are set as a number of pixels away from the center of the search region.

### Inner Radius

Size of the inner ring.

## Thickness

The thickness of the ring; outer radius minus inner radius.

## Use Arcs

This is normally NOT used in this inspection. If enabled, it divides the ring region into arc segments.

## Template Registration menu

Ring	Template Registration	Settings	Template
<input checked="" type="checkbox"/>	Registration Strength		3.0 .. 5.0
	Registration Normalization		Component Magnitude
	Registration Normalization Gain		0.0
<input checked="" type="checkbox"/>	Perform Orientation		
	Orientation Strength		1.5 .. 3.0
	Orientation Normalization		Component Power
	Orientation Normalization Gain		0.0
<input checked="" type="checkbox"/>	Check Scale		
	Image Scale Limits		1.0 +0.51/ -0.51

### Registration Strength

Set the minimum strength, or quality, you require for registration between the inspected image and the template image. This sets the pass/ fail limits. You can set this using the horizontal bar on the Retro-Spec graph (after you select this parameter in the menu).

### Registration Normalization

Normalization uses template data as a reference and compares it to current part data. Normally this does not need to be changed from Component Magnitude. If you are getting inconsistent results, try another technique. Use the technique that works best for your parts. We recommend trying the techniques in this order:

- Component Magnitude - default, used in most applications.
- Component Power - try this as a second option.
- Global Power - try only if Component Magnitude or Component Power do not work for your part.
- Phase Only - not used.

### Registration Normalization Gain

Leave this set at zero.

### Perform Orientation

Select whether an orientation is performed as part of the inspection. This is normally not used, except if you are inspecting parts with decoration on them. We recommend that if you need to perform an orientation (on parts without deco), use a separate **Template Orientation** (on page 246) to save inspection time.

The following parameters are only used if Perform Orientation is enabled.

### Orientation Strength

Set the minimum strength, or quality, you require for orientation between the inspected image and the template image. You can set this through the bar on the graph. If the current part falls below this value, the part fails.

### Orientation Normalization

Normalization uses template data as a reference and compares it to current part data. Normally this does not need to be changed from Component Power. If you are getting inconsistent results, try another technique. Use the technique that works best for your parts. We recommend trying the techniques in this order:

- Component Power- default, used in most applications.
- Component Magnitude - try this as a second option.

- Global Power - try only if Component Magnitude or Component Power do not work for your part.
- Phase Only - not used.

### Orientation Normalization Gain

Leave this set at zero.

### Check Scale

We recommend that you leave this box un-checked. Scale refers to a magnification factor in the event of a change in optics or part movement. It can be used as a reject limit for part size.

### Image Scale Units

[Only used when Check Scale is enabled] Restrict how much the size of the inspected image is allowed to be adjusted to match the template image. A value of one (1) indicates that the size matches exactly. A value less than one means that the image needs to be reduced to match the template. A value greater than one means that the image needs to be enlarged to match the template. If you use this parameter, be aware that it adds time to the inspection. Also know that a setting of 0.9 to 1.1 means that there could be 10% variation in either direction from an ideal part.

## Settings menu

Use the suggested rules, described below, for optimum inspection.

Template Region	
Measure ROI(s)	Template Registratio
<b>Settings</b>	
<b>Standard Settings</b>	
Radial Samples	1024
Angular Samples	1024
Downsize Level	Level 2 (16 to 1)
Grain Reduction Technique	Disabled
Contrast Compression Technique	Disabled
Advanced Orientation	<input type="checkbox"/> Enabled
View Filtered Region	<b>View Filtered Region</b>
Offset Center X	0
Offset Center Y	0
Select Center Offset	<b>Select Center</b>
Color to Grayscale	<input type="checkbox"/> Enabled

### Standard Settings

Click the **Standard Settings** button to automatically set **Radial Samples** and **Angular Samples** based on the current region settings. (In Template Registration, this refers to settings in the Template Registration menu only if Perform Orientation is enabled.)

### Radial Samples

This number divides the region into a number of rings. See example under Angular Samples below. To set this manually, set this to the approximate outer radius of the template region, rounded up. For example, if you have a Ring region, go to the Ring menu, and add Inner Radius plus Thickness to get Outer Radius. In the Settings menu, use the next highest value from the radius.

### Angular Samples

This number divides the region into a number of arcs. See example below.

**Example:** This example shows a region with three (3) radial samples and eight (8) angular samples. (Note: these values are not available in the inspection. These examples and shading are for illustration purposes only.)



### Downsize Level

Using this option depends on the image. For example, if your part image has **grain**, then use a Downsize Level of 4 to 1 - this will blur the image enough to almost ignore the grain. Enabling this option looks at the region differently by grouping pixels. The system will look at pixels in groups of 4 (Level 1), 16 (Level 2), or 64 (Level 3). Larger values reduce the image further, speeding up the inspection at the cost of resolution.

### Grain Reduction Technique

This is an optional filter. Enable this feature only if your part has grain and is causing inspection problems. This filter will help block grain from the image. Use the technique that works best on your part.

### Contrast Compression Technique

This is an optional filter. Enable this feature only if your part has low-frequency changes such as shadows that are causing inspection problems. Use the technique that works best on your part.

### Advanced Orientation

If this is enabled, it provides an enhanced technique to perform the orientation. Note that this increases inspection time.

### View Filtered Region

[Only applicable if any of the filter techniques above are being used] This displays the image area using the filters.

### Offset Center X and Y

We recommend that you leave these values set at zero.

### Select Center Offset

Click the **Select Center** button to initiate the selection. Then click in the image where the center should be. Wait while the system computes the new center values and populates the Offset Center X and Y parameters. Then click the **Select Center** button to complete the selection.

**Offset Angle** and **Select Offset Angle** are only used if Perform Orientation is enabled.

### Offset Angle

Rotate the inspections on an image. Set the angle on a specific feature to match the current orientation of the part. You can use the **Select Angle** button to set this value. This feature saves you from modifying subsequent regions during slight changes that might affect region placement.

❖ *Note: this angle can only be set after you create a template.*

### Select Offset Angle

Click the **Select Angle** button to initiate the selection. Then click in the image where the orientation should point to. Wait while the system computes and then populates the Offset Angle parameter. Then click the **Select Angle** button to complete the selection.

### Color to Grayscale

Not used.

## Support Ring Registration

The Support Ring Registration is used in the filling application to locate both sides of the neck ring on a bottle and then position the following inspections with respect to these points. This registration always uses a **Measure ROI** (on page 198) Region. The Support Ring registration finds the edges of the neck ring, then it computes the diameter of the neck ring as well as the tilt of the bottle.

❖ *Note: Support Ring Registration requires a **Measure ROI** (on page 198) region.*

### ➤ *Before adding a Support Ring registration:*

- Add a **Measure ROI** (on page 198) Region of Interest to the inspection tree (if you do not already have one). This region of interest should cover the support ring, a portion of the cap, and enough of the bottle so that it can accurately determine the tilt of the bottle. It should also be able to accommodate some part movement in the camera's field of view, but make sure that adjacent bottles cannot be seen in region.
- The Measure ROI region of interest should be oriented such that the search direction is pointing towards the cap.
- A sample Measure ROI placement is shown below.

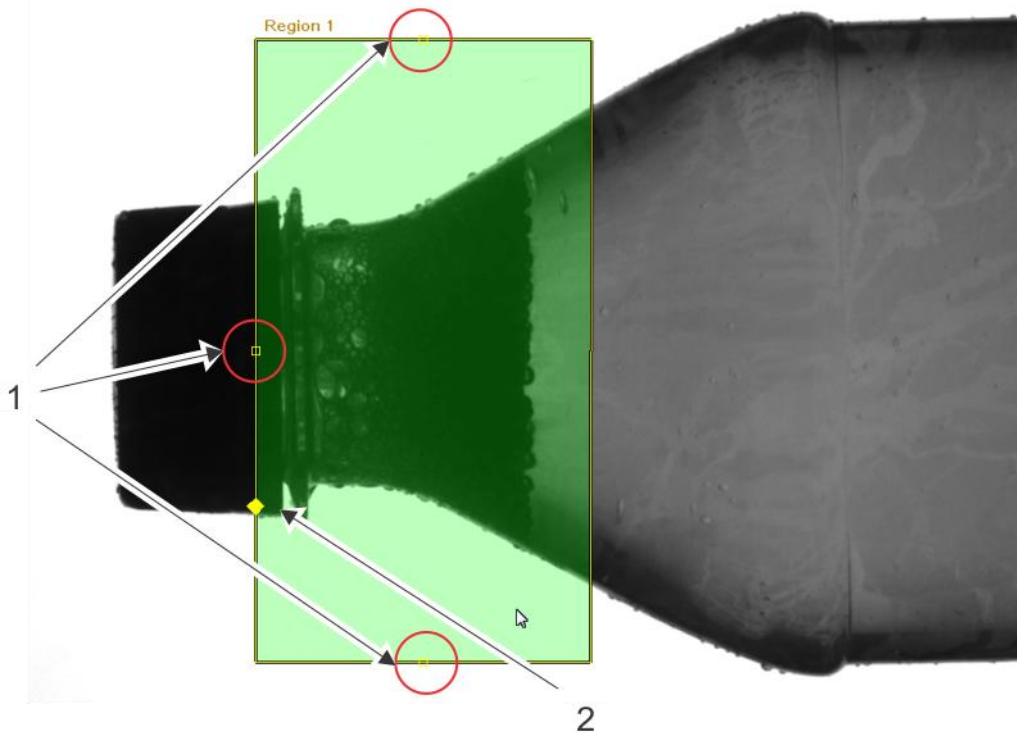

### Measure ROI placement for Support Ring Registration

1	Measure ROI re-sizing handles. Make sure these are oriented towards the cap and sides.
2	Yellow diamond indicates search direction. Make sure search direction is towards cap.

### ➤ *To add a Support Ring registration:*

1. Make sure a Measure ROI region of interest has been added to the inspection tree. A sample Measure ROI placement is shown above.
2. Right-click on the name of the region you just added.

- From the Inspection menu, select Add > Registration > Support Ring. The registration is added to the inspection tree. Re-name it to something more meaningful to you.
- The Support Ring menus are displayed and the region is shown on the image. (The menus are described below) Adjust the placement of the region and parameters as necessary.

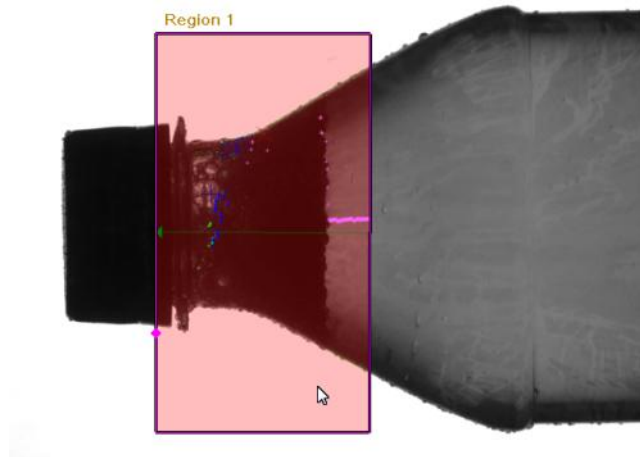

## Support Ring Registration menu

Use the Support Ring Registration tab to locate the support ring. Use the settings recommended by Pressco support engineers, and adjust as necessary for your part.

❖ *Tip: use the **Learn Settings** button to allow the system to automatically learn the parameters for this menu. Then adjust the remaining parameters as necessary.*

Measure ROI(s)	Support Ring Registration	Calibration
Candidate Threshold	15	
Candidate Delta	10	
Candidate Thickness	3	
Learn Settings		<b>Learn Settings</b>
[-] Tilt Limits	268.64° +/-31.4°	
Nominal	268.64°	
[-] [R] Distance Limits	405.59@ +/-27.2@	
Nominal	405.59@	
Show Vectors	<input type="checkbox"/> Enabled	
Show Search Direction	<input type="checkbox"/> Enabled	
Show Edges	<input checked="" type="checkbox"/> Enabled	
[-] @Edge Location Setup		
Edge Polarity	Light-to-Dark	
Edge Gradient	6 .. 54	
Edge Delta	5	

❖ *Note: The symbol [@] indicates that this value is in pixels. Your system may show [mm] for millimeters, ["] for inches, or [ ] blank for custom units. It indicates that this value can be calibrated using **Review Camera Calibration** (on page 144) or **Image Analysis** (on page 138) for the current sensor.*

### Candidate Threshold

The minimum distance you expect the support ring to extend from the profile of the bottle. Set this value at a minimum distance, such as 15. Setting this value too high may make the inspection less accurate if there is water under the support ring.

### Candidate Delta

The number of pixels between each edge comparison that the system looks for transitions that indicate the support ring. The system looks at the edge profile of the bottle. A typical setting is 10.

### Candidate Thickness

The minimum width (in pixels) that you expect the support ring to be. You can usually set this to a small value, such as five.

### Learn Settings

Click this button to automatically set the parameters to find the support ring edges.

### Tilt Limits

Set the allowed range of tilt of the part within the image.

### Nominal

The expected degree of tilt.

### Distance Limits

Specify the minimum and maximum distance between the two reference points.

### Nominal

The ideal distance.

### Show Vectors

Show the search lines on the image.

### Show Search Direction

Show the search direction of the vectors with an arrow.

### Show Edges

Show the found edges on the image.

## Edge Location Setup

### Edge Polarity

Choose the type of edge to search for – Light to Dark, Dark to Light, or Either. For example, if the feature you want to find is very bright, choose Dark to Light.

### Edge Gradient

The minimum and maximum difference in gray shades, between two pixels, to be considered an edge.

### Edge Delta

The distance between pixels being compared when seeking an edge. A higher Delta value is more sensitive because it finds more edges.

## Calibration menu

Use this menu to program the system to translate pixels into your desired units of measure (mm, for example).

Support Ring Search	Calibration
Calibration Mode	Inspection Calibration
Units	Pixels
Conversion Factor	1.0
Learn Calibration	Learn Calibration
Save Calibration	Save Calibration
Measured Distance	-1.0

### Calibration Mode

The system will convert the pixel dimensions into your preferred unit of measurement.

**Sensor Calibration** -- Use the calibration previously set up for the sensor through **Image Analysis** (on page 138) or through another inspection.

**Inspection Calibration** -- Use the calibration from this inspection only.

### Units

Choose your preference in the reporting of the measurements. Choose from millimeters, inches, pixels, and custom. Custom allows any calibration factor to be used.

### Conversion Factor

This indicates the pixel size and is used to convert one pixel into the units selected. The initial conversion will be controlled by the Learn Calibration results. You can adjust this value manually if necessary.

### Learn Calibration

Click the **Learn Calibration** button to automatically determine the scale factor, which converts the value to the desired units.

❖ *Note: you must first enter the Measured Distance before learning calibration.*

### Save Calibration

Click the **Save Calibration** button to save the calibration scale and units to the sensor for use by other inspections.

### Measured Distance

Measure your part with calipers or another tool, then enter the actual value for Measured Distance. This is used to help calibrate the measurement.

# Orientations

An orientation compensates for part rotation by finding a grayscale pattern. An analysis which must rotate with the part must follow an orientation.

❖ *Note: you must first place a **Region of Interest (ROI)** (see "**Regions of Interest (ROI)**" on page 192) where you want the Orientation to take place.*

Available orientations include **Pattern Match** (on page 244) and **Template Orientation** (on page 246).

❖ *Note: the **Centerline** (on page 225) and **Template** (see "**Template Registration**" on page 231) Registrations also contain an orientation angle that can be used to orient regions.*

## Pattern Match

Pattern Match Orientation creates a pattern to be matched. A Pattern Match reference must be set on one part that you consider to have the desired pattern. The Pattern Match reference sets the standard to which all other parts inspected must meet. The Pattern Match is based on percentages; the referenced pattern will be 100%. All other parts will be compared to the referenced pattern and given a percentage depending on how the two patterns match up. In other words, a part with an 88% Pattern Match rating is 88% similar to the referenced part. If the inspected part has too low of a percentage, the part will fail the orientation.

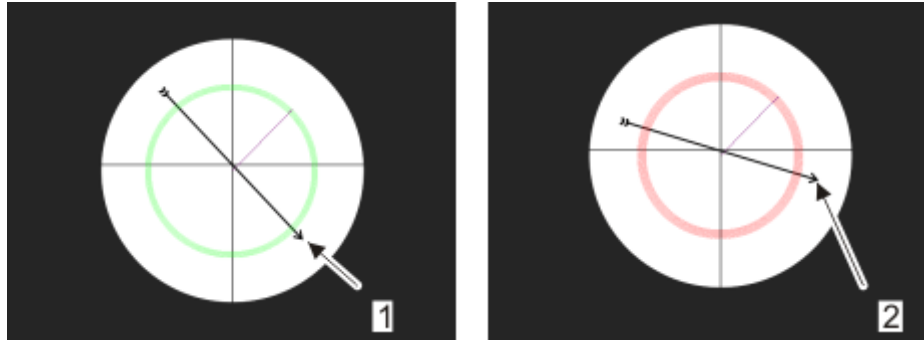

1	Normal orientation
2	Incorrect orientation

❖ *Note: Pattern Match only works with a **Ring Region** (on page 193).*

### ➤ **To add a Pattern Match Orientation:**

1. Make sure a **Ring Region** (on page 193) of Interest has been added to the inspection tree. Normally the region is a narrow donut-shaped region placed over a repeatable pattern on the part, such as ridges or other geometry.
2. Right-click on the item you just added.
3. From the Inspection menu, select Add > Orientation > Pattern Match. The Pattern Match orientation is added to the inspection tree.
4. The Pattern Match menu is displayed and the region is shown on the image. (The menu is described below) Adjust the placement of the region and parameters as necessary.

## Pattern Match menu

Ring	Pattern Match
Symmetry Repeat	1
Radial Spacing	1
Select Offset Angle	
Offset Angle	0.0°
Set Reference	
Show Orientation	<input checked="" type="checkbox"/> Enabled
Part View Display	Show Pattern
Show Pattern Match	<input type="checkbox"/> Enabled
Region Extraction	Read Radially
<input type="checkbox"/> Reject Limits	
 Pattern Match Confidence	30% .. 40%

❖  **Important:** Set Reference before adjusting other parameters.

### Symmetry Repeat

Divide the donut-shaped region into a number of pie-shaped sections. The system need only match the gray shade pattern in one of these sections to determine proper orientation.

An example for the use of symmetry is when you are inspecting the base of a bottle that has five feet - use a symmetry of five. The system uses a gray shade pattern in one-fifth of the region, and you are assured proper orientation because these gray shade patterns are identical in the other four sections of the region.

This feature can speed up this orientation. The time required for the orientation is reduced by 1/symmetry squared. If you have a symmetry of five, this orientation takes 1/25th the amount of time it would take with a symmetry of one.

### Radial Spacing

The number of pixels between search circles. It can be used to increase the speed of this inspection, especially if the region is large.

### Select Offset Angle

Set the Offset Angle (described below). Click the **Select Angle** button, then click in the image where you want the orientation to point to.

❖ *Note: you can only set Offset Angle if the inspection is passing. You may have to adjust other parameters, or disable other inspections while setting this to get the inspection to pass.*

### Offset Angle

Allows you to rotate the inspections on an image. Set the angle on a specific feature to match the current orientation of the part. This feature saves you from modifying subsequent regions during slight changes that might affect region placement.

### Set Reference

Click the Set Reference button  to set the reference pattern from the currently displayed image.

### Show Orientation

Display the orientation line on the image.

### Part View Display

Allows you to look at different results for the part. You must enable 'Show Pattern Match' to see the information in the unwrapped image.

**Show Correlation Plot** - Displays a plot to show the correlation between the reference pattern and the current image in the unwrapped image.

**Show Pattern** - Displays the extracted grayscale pattern of the current image.

**Show Normalized Pattern** - Displays the extracted grayscale pattern of the current image; the values are normalized so that the highest value is one.

**Show Pattern Delta** - Displays a plot of the differences in the pattern.

### Show Pattern Match

Display a graphical plot of the pattern match on the unwrapped image. An example is shown below.



### Region Extraction

Choose how the Intellispec should read the information from the region. This usually depends on the shape of your region. In this inspection, only Read Radially is used. The data is extracted in a radial direction as shown in the illustration below.

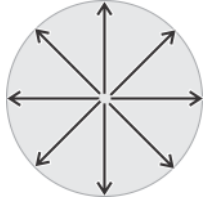

### Pattern Match Confidence

Define how closely the pattern must match the original sample. To adjust this value, you can change the numerical value, or click and drag the red line in the Retro-Spec graph at the top of the screen. If you check Show Pattern Match, you can see the red failure limit line in the unwrapped image move when you change this value.

## Template Orientation

Template Orientation can determine the orientation of a feature that is either irregularly shaped, or is located in a region with a lot of gray scale variation. However, it can be used on any part. It is fast and accurate.

- ❖ *Note: if you have a part that requires using symmetry, such as the base of a plastic bottle, or a lugged closure, use **Pattern Match** (on page 244) to find the orientation.*
- ❖ *Note: you must have a registration in the part program prior to the Template Orientation. The registration will locate the part and allow the Template Orientation to be properly placed.*

### ➤ **Before adding a Template Orientation:**

1. Add a registration that will best locate your part.

2. Add a region of interest in the area where you want to place the Template Orientation. An example is shown below. We want to orient the part using the rivet and the surrounding part geometry.

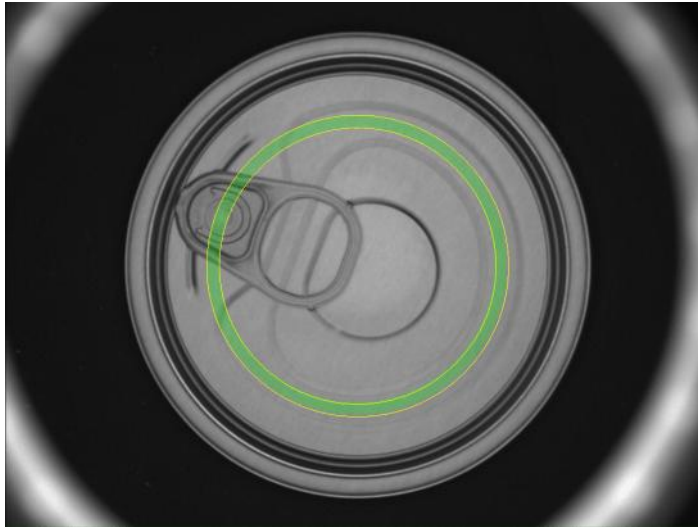

➤ **To add a Template Orientation:**

1. Make sure a region of interest has been added to the inspection tree. A sample Ring region placement is shown above.
2. Acquire about 100 images to get a good sample population of part images:
  - Put the lane online, long enough to acquire about 100 images. Take the lane offline.
  - **OR:** Use **Offline Imaging** (on page 137). Right-click the Sensor button to see the Sensor menu > select Offline Imaging > Immediate Mode **Run** button. Exit the Offline Imaging screen after acquiring about 100 images.
3. Right-click on the item you just added.
4. From the Inspection menu, select Add > Orientation > Template Orientation. The orientation is added to the inspection tree. Re-name it to something more meaningful to you.
5. The Template Orientation menus are displayed and the region is shown on the image. (The menus are described below) Adjust the placement of the region and parameters as necessary.

Next, choose an image and save it as a template as follows:

➤ **To save a template image:**

1. From the Retro-Spec inspection screen, find an image that represents a regular part - not the best image, not the worst image, but a typical part image. Use the forward/ backward arrows to scroll through the acquired images.
2. If necessary, adjust the region size and placement to cover an area where there is a repeatable and distinct grayscale pattern.
3. Go to the Template menu (described below) and click the **Save Template** button. An on screen keyboard is displayed.
4. Name the template image and click the OK button  to save. A Saved Template dialog box is displayed with the name and location of the saved template image.

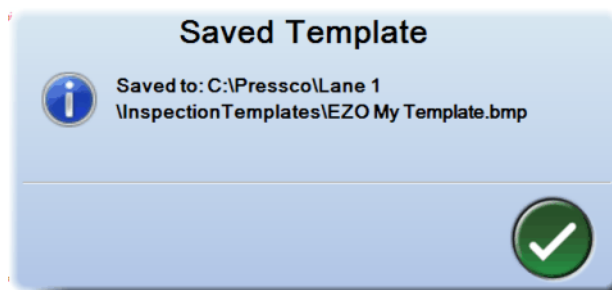

- Click the OK button to close the message. You can set the remaining parameters of the Template menu at a later time.

Next, set the parameters in the other menus. Use the steps below for quick setup of the orientation. Depending on your part and application, you may need to make other adjustments after these steps. The parameters for each of the menus are described below.

➤ **To set up the Template Orientation:**

- In the Template Region menu, make sure Use Inspection Region is selected.
- In the Settings menu, click the **Standard Settings** button so that the system can adjust to the image.
- In the Settings menu, click the **Select Angle** button. Click in the image where the orientation should point to. Wait while the system populates the Offset Angle parameter. Then click the **Select Angle** button again to complete the process.
- In the Template Orientation menu, adjust Orientation Strength to pass or fail the part. This can be adjusted using the bars on the graph.
- Acquire more images and test the orientation. Make other adjustments as necessary in the menus, making sure that the orientation is properly found on each part, and that improperly oriented components make the part fail.

Below is an example of how a Template Orientation looks on a part.

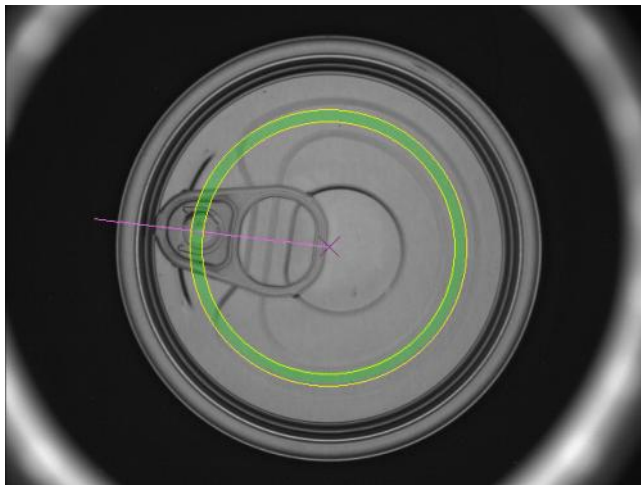

The menu parameters are described below.

### Template Region menu

Make sure that **Use Inspection Region** is selected. This setting should be used unless otherwise instructed by Pressco.

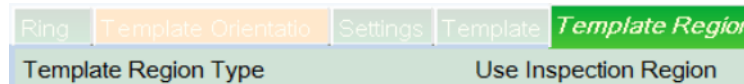

### Settings menu

Use the **Standard Settings** button and **Select Angle** button for easy setup in this menu.

If your inspection is not getting consistent results, set the **Angular Samples**, **Downsize Level**, and **Offset Angle**, using the guidelines described below.

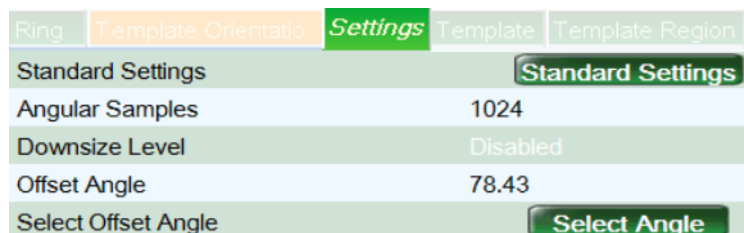

## Standard Settings

Click the **Standard Settings** button to automatically set **Radial Samples** and **Angular Samples** based on the current region settings. (In Template Registration, this refers to settings in the Template Registration menu only if Perform Orientation is enabled.)

## Angular Samples

This number is automatically set by clicking the Standard Settings button (in the Settings menu). This number divides the region into a number of arcs. See example below.

**Example:** This example shows a region with three (3) radial samples and eight (8) angular samples. (Note: these values are not available in the inspection. These examples and shading are for illustration purposes only.)



## Downsize Level

Using this option depends on the image. For example, if your part image has **grain**, then use a Downsize Level of 4 to 1 - this will blur the image enough to almost ignore the grain.

Enabling this option looks at the region differently by grouping pixels. The system will look at pixels in groups of 4 (Level 1), 16 (Level 2), or 64 (Level 3). Larger values reduce the image further, speeding up the inspection at the cost of resolution.

For Template Orientation, this can be left disabled for most applications.

## Offset Angle

Rotate the inspections on an image. Set the angle on a specific feature to match the current orientation of the part. You can use the **Select Angle** button to set this value. This feature saves you from modifying subsequent regions during slight changes that might affect region placement.

❖ *Note: this angle can only be set after you create a template.*

## Select Offset Angle

Click the **Select Angle** button to initiate the selection. Then click in the image where the orientation should point to. Wait while the system computes and then populates the Offset Angle parameter. Then click the **Select Angle** button to complete the selection.

## Template Orientation menu

Set the parameters in this menu to pass or fail the part based on orientation.

Ring	Template Orientation	Settings	Template	Template Region
Orientation Strength	1.5			
Orientation Normalization	Component Power			
Orientation Normalization Gain	0.0			

## Orientation Strength

Set the minimum strength, or quality, you require for orientation between the inspected image and the template image. You can set this through the bar on the graph. If the current part falls below this value, the part fails.

## Orientation Normalization

Normalization uses template data as a reference and compares it to current part data. Normally this does not need to be changed from Component Power. If you are getting inconsistent results, try another technique. Use the technique that works best for your parts. We recommend trying the techniques in this order:

- Component Power- default, used in most applications.
- Component Magnitude - try this as a second option.

- Global Power - try only if Component Magnitude or Component Power do not work for your part.
- Phase Only - not used.

### Orientation Normalization Gain

Leave this set at zero.

## Template menu

This menu allows you to save a template image, view the selected template image, and create a region that is different from the region of interest that the orientation uses.

Ring	Template Orientation	Settings	Template	Template Region
Selected Template		Generic EZO Panel.bmp		
Use Common Template Region		<input checked="" type="checkbox"/> Enabled		
Template Center X		320		
Template Center Y		240		
Template Region Radius		240		
Save Template Image		<a href="#">Save Template</a>		
View Template Image		<a href="#">View Template</a>		

### Selected Template

Select any saved template from the drop-down menu. If no templates have been created, no drop-down menu is available.

### Use Common Template Region

[only available after more than one template is saved] There are two regions to consider: the template region and the search region. Using a Common Template Region uses the same region for both. Using this feature depends on your part. When you have an image that does not work well with other registrations, such as a rivet on a converted end, an EZO end, or rectangular bottles, then un-check Common Template Region.

Where possible, use another registration such as Radial Edge or Hough prior to this inspection, and Use Common Template Region. This allows you to keep the region smaller, and uses less processing time.

### Template Center X and Y

This is not normally used in an orientation. However, it allows you to offset the center of this region from the center found by the registration that this orientation uses.

### Template Region Radius

This is not normally used in an orientation. However, it allows you to adjust a region radius different from the one set up by the region of interest.

### Save Template Image

Save the current image as a template.

## View Template Image

To verify that you have selected the correct template image, click the **View Template** button. A pop-up window displays the saved template image. An example is shown below.



❖ *Note: displaying the template image does not display it in the Intellispec image area.*

---

## Analyses

These analyze the part for defects, features, measurements, or gray shades.

❖ *Note: you must first place a **Region of Interest** (see "**Regions of Interest (ROI)**" on page 192) where you want the analysis to take place. We also recommend a **Registration** (see "**Registrations**" on page 215) and an **Orientation** (see "**Orientations**" on page 243) (depending on the part type) prior to an analysis.*

The available types of analyses are:

- **Ambient** (on page 251)
- **Shape Check** (on page 254)
- **Contrast** (on page 255)
- **Measurement** (on page 261)
- **Fill Height** (on page 269)
- **Measure Extract** (on page 275)
- **Distribution** (on page 276)
- **Label Skew Extract** (on page 282)
- **Feature Detect** (on page 284)

❖ *Note: Your system (and this book) may show only those items that apply to your application.*

## Ambient

Ambient is a measure of gray levels in a selected region and looks for abnormal gray levels. There are three ways in which to measure a part's ambient: Max Amplitude, Peak Percentile, and Density. You can set the Ambient Analysis Mode to have maximum reject limits, minimum reject limits, or a combination of maximum and minimum reject limits.



1	Normal Ambient
2	Incorrect Ambient

➤ **To add an Ambient analysis:**

1. Make sure a **Region of Interest (ROI)** (see "**Regions of Interest (ROI)**" on page 192) has been added to the inspection tree. We also recommend a **Registration** (see "**Registrations**" on page 215).
2. Right-click on the item you just added.
3. From the Inspection menu, select Add > Analysis > Ambient. The Ambient analysis is added to the inspection tree.
4. The Ambient menu is displayed and the region is shown on the image. (The menu is described below) Adjust the placement of the region and parameters as necessary.

### Ambient menu

Polygon	Ambient
Ambient Technique	Density
Ambient Analysis Mode	Min & Max
Region Extraction	Read Radially
<input type="checkbox"/> Ambient Limits	
Nominal	128

#### Ambient Technique

This method determines the region's ambient. Choose the method through the drop-down menu.

- **Max Amplitude** looks for the maximum gray level amplitude — the gray level with the most pixel counts — within the histogram of the search area.

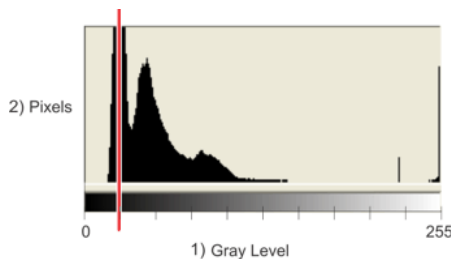

1	Gray level
2	Pixels in the histogram of the image

**Peak Percentile** locates the gray level value that exceeds the **threshold**. In the example below, the system would use the gray level to the right of the line marking 80%.

- **Ambient Threshold** defines what percentage of the search area to use.

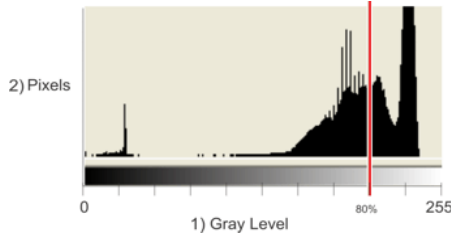

1	Gray level - choose a percentage
2	Pixels in the histogram of the image

- **Density** computes the average of all the pixel gray levels — total gray level divided by pixels.

### Ambient Analysis Mode

Specify the reject criteria.

**Min & Max** - The minimum and maximum acceptable ambient gray level values. Any computed ambient found lower than or greater than these values will cause the inspection to fail.

**Min Only** - The minimum acceptable ambient gray level value. Any computed ambient found lower than this value will cause the inspection to fail.

**Max Only** - The maximum acceptable ambient gray level value. Any computed ambient found greater than this value will cause the inspection to fail.

### Region Extraction

Choose how the Intellispec should read the information from the region. This usually depends on the shape of your region.

❖ *Note: some inspections do not use all of these options*

The illustration below shows how the information is read by each method. Note that these shapes are examples only - your region does not have to match the shape.

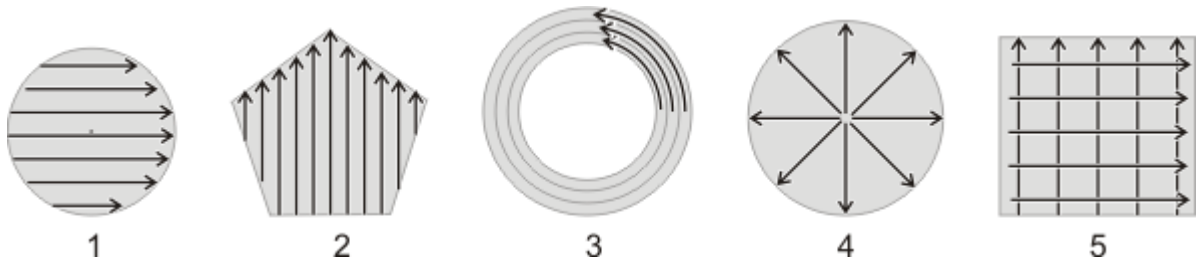

1	<b>Read Horizontally</b> - Extract the region horizontally - 90 degrees with respect to orientation.
2	<b>Read Vertically</b> - Extract the region vertically - parallel with respect to orientation.
3	<b>Read Circularly</b> - Extract in a circular fashion around the region.
4	<b>Read Radially</b> - Extract region in a radial direction.
5	<b>Read Horizontally and Vertically</b> - Extract the region both horizontally and vertically (with respect to orientation). This is used in special cases.

### Ambient Limits

The minimum and maximum acceptable ambient gray level values. Any computed ambient found lower than or greater than these values will cause the inspection to fail.

### Nominal

The expected gray level value of the region of interest.

## Shape Check

Shape Check looks for a certain shape in the search region and will reject a part if it is out of tolerance. This feature helps ensure that the custom search region does not get fooled by an irregularly shaped container.

❖ *Note: This inspection is only available for Adaptive Regions.*

*Series IV users: Shape Check is similar to the Shape Adapt region analysis in Series IV.*

The example below shows a normal part [item 1], and a part that failed the Shape Check [item 2].

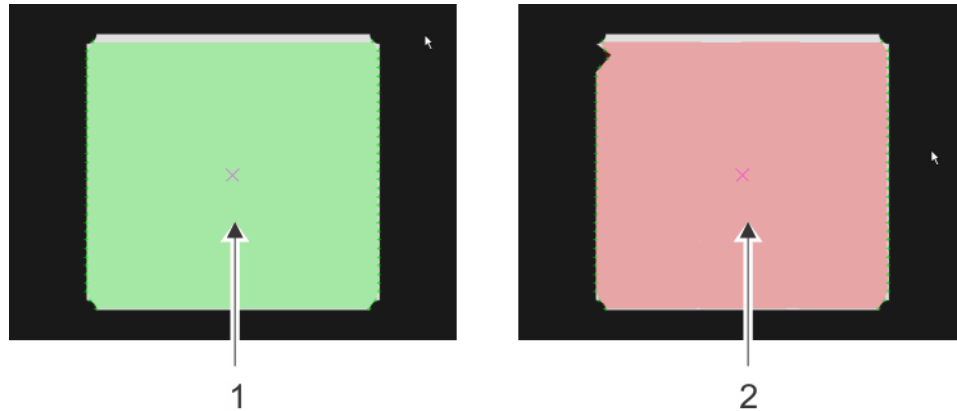

1	Normal part
2	Part failed Shape Check

### ➤ *To add a Shape Check inspection:*

1. Make sure an **Adaptive Region** (on page 200) of Interest has been added to the inspection tree.
2. Right-click on the item you just added.
3. From the Inspection menu, select Add > Analysis > Shape Check. The analysis is added to the inspection tree. Re-name the inspection to something more meaningful to you.
4. The Shape Check menu is displayed and the region is shown on the image. (The menu is described below) Adjust the placement of the region and parameters as necessary.

### **Shape Check menu**

Select between three different methodologies to determine proper shape (Area Check, Cross Section Check, and Vertex Deviation Check).

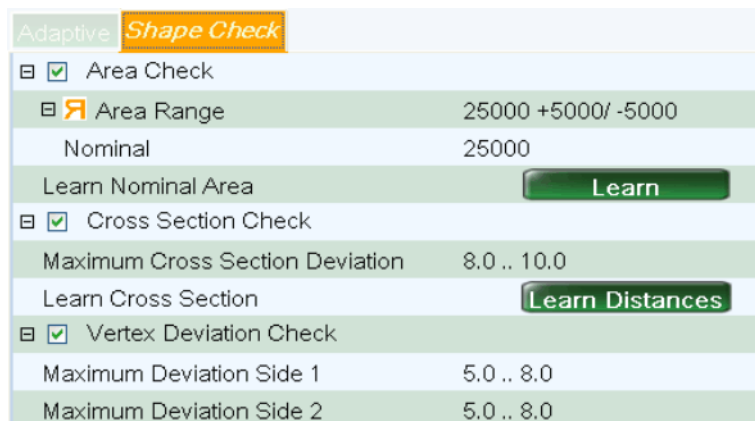

### Area Check

Enable the Area Range portion of the inspection. This computes the area of the region in pixels to check for proper region size.

### Area Range

Define the acceptable deviation (in pixels) from the normal area of the region. You may also adjust the values on the Retro-Spec graph.

### Nominal

The expected area size. This number is populated when you press the **Learn** button.

### Learn Nominal Area

Click the **Learn** button to automatically learn the area.

### Cross Section Check

Enable the Cross Section portion of the inspection. This is only used when an Adaptive region is added to a Centerline registration. The system ensures that the learned distance between the two sets of points is within tolerance.

### Maximum Cross Section Deviation

First use the **Learn Cross Section** button to determine the normal values. The distance is in pixels. Then adjust these values per your specifications.

### Learn Cross Section

Click this button to determine the normal values for the Cross Section check.

### Vertex Deviation Check

Enable the Vertex Deviation Check portion of the inspection. This is only used when an Adaptive region is added to a Centerline registration. This check looks at the deviation between consecutive edge points, and is performed on each side. An example where this feature might be used is when searching for choked necks on bottles.

The vertex edge points are determined when you use Learn Cross Section.

### Maximum Deviation Side 1 and 2

The system computes the distance (in pixels) between consecutive edge points. Adjust the sensitivity per your specifications.

## Contrast

The Contrast analysis looks for light and dark defects within your desired region. You can set the Contrast analysis to look for light defects only, dark defects only, or both light and dark defects. In the example image below, a Contrast analysis found a scratch.



### ➤ To add a Contrast analysis:

1. Make sure a **Region of Interest** (see "**Regions of Interest (ROI)**" on page 192) has been added to the inspection tree. We also recommend a **Registration** (see "**Registrations**" on page 215).
2. Right-click on the item you just added.
3. From the Inspection menu, select Add > Analysis > Contrast. The Contrast inspection is added to the inspection tree. Re-name it to something more meaningful to you.

- The Contrast menu is displayed and the region is shown on the image. (The menu is described below) Adjust the placement of the region and parameters as necessary.

## Contrast menu

❖ *Note: The symbol [Ⓢ] indicates that this value is in pixels. Your system may show [mm] for millimeters, ["] for inches, or [ ] blank for custom units. It indicates that this value can be calibrated using **Review Camera Calibration** (on page 144) or **Image Analysis** (on page 138) for the current sensor.*

Polygon Contrast	
Contrast Limits	71.48 .. 114.98
Size Filter	21.0Ⓢ .. 485.0Ⓢ
Acceptable Size	0.0Ⓢ
Use Size Weighting	<input type="checkbox"/> Enabled
Sizing	Total Width
Region Extraction	Read Radially
Advanced Settings	
Sample Filter	Integration Sampling
Fuzzy Edge Removal	Disabled
Defect Type	Light and Dark Defects
Optimize Settings	<b>Optimize</b>
Detection Mode	Defect Detect
Segment Settings	
Number of Rings	1
Segment Count	1

### Contrast Limits

Set the sensitivity of the inspection. You can also move the red and yellow bars on the Retro-Spec graph by selecting the arrows to the left of the graph.

### Size Filter

Choose a defect size you want to catch. For example, you may want to pass very small defects but fail larger ones. For example, if Size Filter is set to 3 -- 80, any defects smaller than three pixels or larger than 80 pixels would be ignored.

### Acceptable Size

This looks at the width of only those peaks that go above the contrast bar. It sums up the total size of those peaks and puts a limit on how large the *total size* of the defects can be. In the Part View graph shown below, there are peaks that go above the contrast bar. However, Acceptable Size is set to a number greater than the sum of those peaks, and this part passes. Acceptable Size allows you to pass parts with some anomalies, but reject parts with too many anomalies.

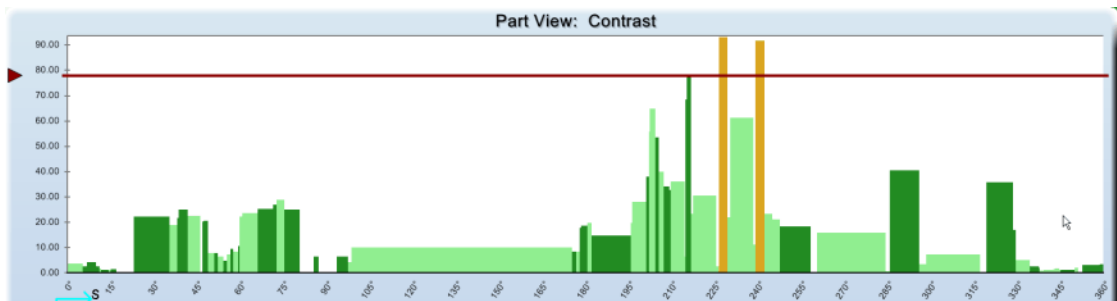

### Use Size Weighting

This feature helps find defects such as wrinkles on metal parts. It is not normally used on bottles.

- If an area of the part fails, it is weighted. If the area does not fail, it is not weighted.

- The Acceptable Size parameter changes to provide adjustment for weighting.
  - The left value is Acceptable Size; see the description for that parameter.
  - The right value adjusts the weighted size limit.

### Sizing

Choose between Total Width and Total Area for the inspection. The Number of Rings also affects Sizing.

- **Total Width**, the default setting, adds the number of units (pixels, millimeters, etc.) of defective bars at or above the sensitivity level within an inspection region or segment.
- **Total Area** adds all the defect pixels. Suppose your part had two small defects along the same radial line. Normally, the width of the predominant defect would be counted. But with Area enabled, all defect pixels are counted. This results in a larger defect area counted.

### Region Extraction

Choose how the Intellispec should read the information from the region. This usually depends on the shape of your region.

❖ *Note: some inspections do not use all of these options*

The illustration below shows how the information is read by each method. Note that these shapes are examples only - your region does not have to match the shape.

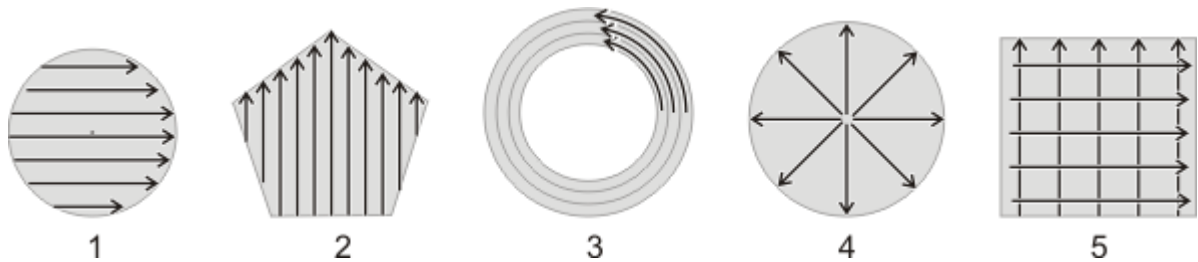

1	<b>Read Horizontally</b> - Extract the region horizontally - 90 degrees with respect to orientation.
2	<b>Read Vertically</b> - Extract the region vertically - parallel with respect to orientation.
3	<b>Read Circularly</b> - Extract in a circular fashion around the region.
4	<b>Read Radially</b> - Extract region in a radial direction.
5	<b>Read Horizontally and Vertically</b> - Extract the region both horizontally and vertically (with respect to orientation). This is used in special cases.

## Advanced Settings

### Sample Filter

Choose how to filter the samples. The default selection is Integration. Leave that selected for most applications. Concavity is used for detecting and ignoring draw marks in two-piece beverage cans.

### Fuzzy Edge Removal

This is for parts that have normal anomalies at the edges that are fuzzy, but the feature edges are sharp and clear on the image. The default is disabled. The higher the Filter Level, the stronger the fuzzy edge removal. Be aware that this filtering increases inspection time.

### Defect Type

Search for dark, light, or both types of defects.

### Optimize settings

Described below.

### Detection Mode

Search for either a defect (default setting) or for a feature (for example, a feature that should be there and its absence represents a defect).

## Segment Settings

### Number of Rings

The number of concentric rings the region is divided into (for Read Circularly or Read Radially Region Extractions only). More rings generally means more sensitive.

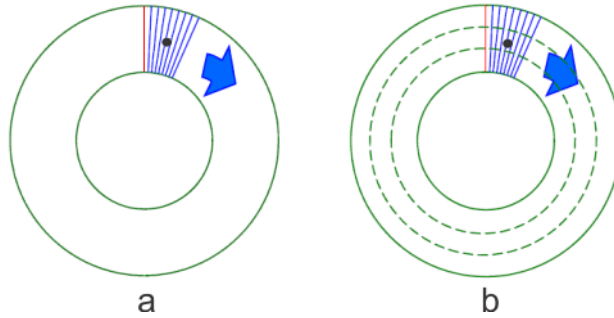

a	Region with one ring
b	Region divided into three rings

The example below shows a Part View graph of the same part's region with one ring [item 1], and that same region divided into several rings [item 2]. Notice that the width of the peaks do not change, but the amplitude of the peaks change, because the system is focusing on a smaller region.



1	Part with region with one ring
2	Same part with region divided into several rings

### Number of Segments

The number of angular segments the region is divided into.

## Ring Height

Ring Height is similar to Number of Rings, but applies to a polygon region. This number refers to a number of pixels wide or high, depending whether you are using Read Horizontally or Read Vertically for Region Extraction. Ring Height can improve inspection sensitivity to defects that do not span the width of the inspection region. The default value for Ring Height is one, which is the most sensitive value. In the example below, suppose Ring Height in [item 1] is one pixel, and Ring Height in [item 2] is five pixels. In this case, the part using Ring Height of one [item 1] would be more likely to fail than with a Ring Height of five [item 2].

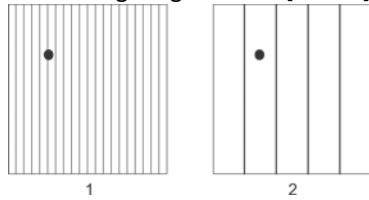

1	Smaller Ring Height - more sensitive
2	Larger Ring Height - less sensitive

## Using the Optimize feature

The Optimize feature automatically sets the optimum settings for many inspection parameters. It is processor-intensive and must be done off-line. For this to work correctly, ensure that you have moved all acceptable images to the left side of the Retro-Spec graph (Set A), and the defect images to the right side of the graph (Set B). Optimize is available under the **Advanced Settings**.

### ➤ To use the Optimize feature:

1. Make sure the Retro-Spec graph is in Population view: right-click on the graph to select Population View.
2. Load a set of good parts into Data Set A using the steps below.

### ➤ To load Data Set A:

1. Look at the **Retro-Spec Population View Graph** (on page 185).
2. Click the left arrow  button on the Retro-Spec graph to view the **Select Data Sets** menu.

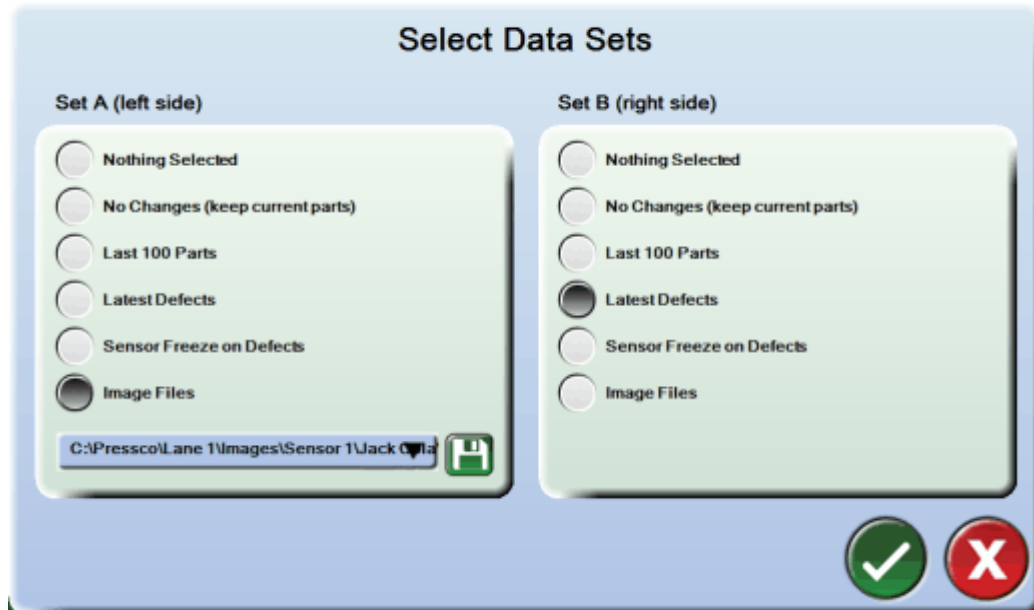

3. Click the Image Files button for Set A.

- Click the disk icon  to browse to the folder where the images were saved. The **Select File** menu is displayed.

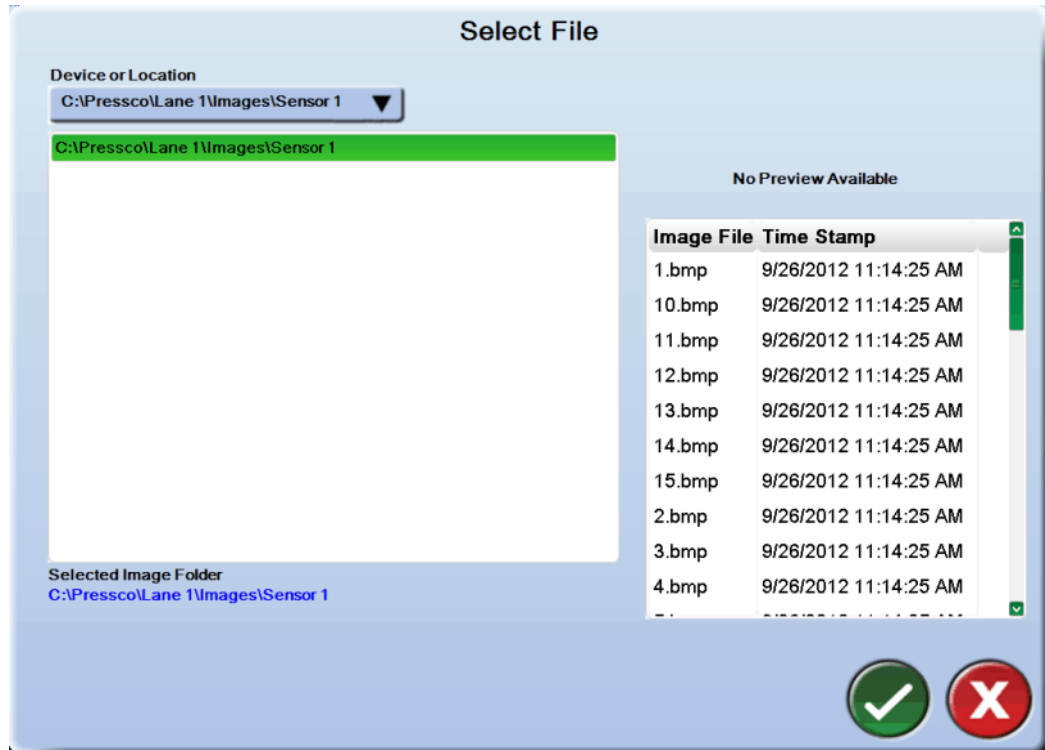

- Browse to and select the folder that contains the images you want to load.
- Click the OK button  in the Select Location and Select Data Sets menus to load all the bitmap images that were previously saved in the selected folder.

Next load a set of images of bad parts into Data Set B. These parts should have defects in the current inspection's region of interest.

➤ **To load images of bad parts:**

- Click the right arrow button  to view the **Select Data Sets** menu.
- From the Select Data Sets menu, select Latest Defects, or choose Image Files for Set B. If you choose Image Files, select images similarly as you did for Set A, except this time choose defect images.
- Exit the Select Data Sets menu.

If there are any parts that do not belong in either sample set, try moving or deleting those samples [refer to the illustration below].

- To move an image:
  - Click on the image lock icon [item 1] to allow images to be moved.
  - Then click and hold the desired image's peak [item 2] - it displays a small image - and drag it to the other side of the center.
- To delete an image:
  - Click on the image lock [item 1] to allow images to be moved.
  - Then click on the desired image's peak [item 2] - it displays a small image - and drag it to the trash can icon [item 3].
  - OR: Click on the desired image's peak [item 2] - and then click the trash can icon [item 3].

- The system displays a "Deleted!" message above the trash can icon when it is deleted.

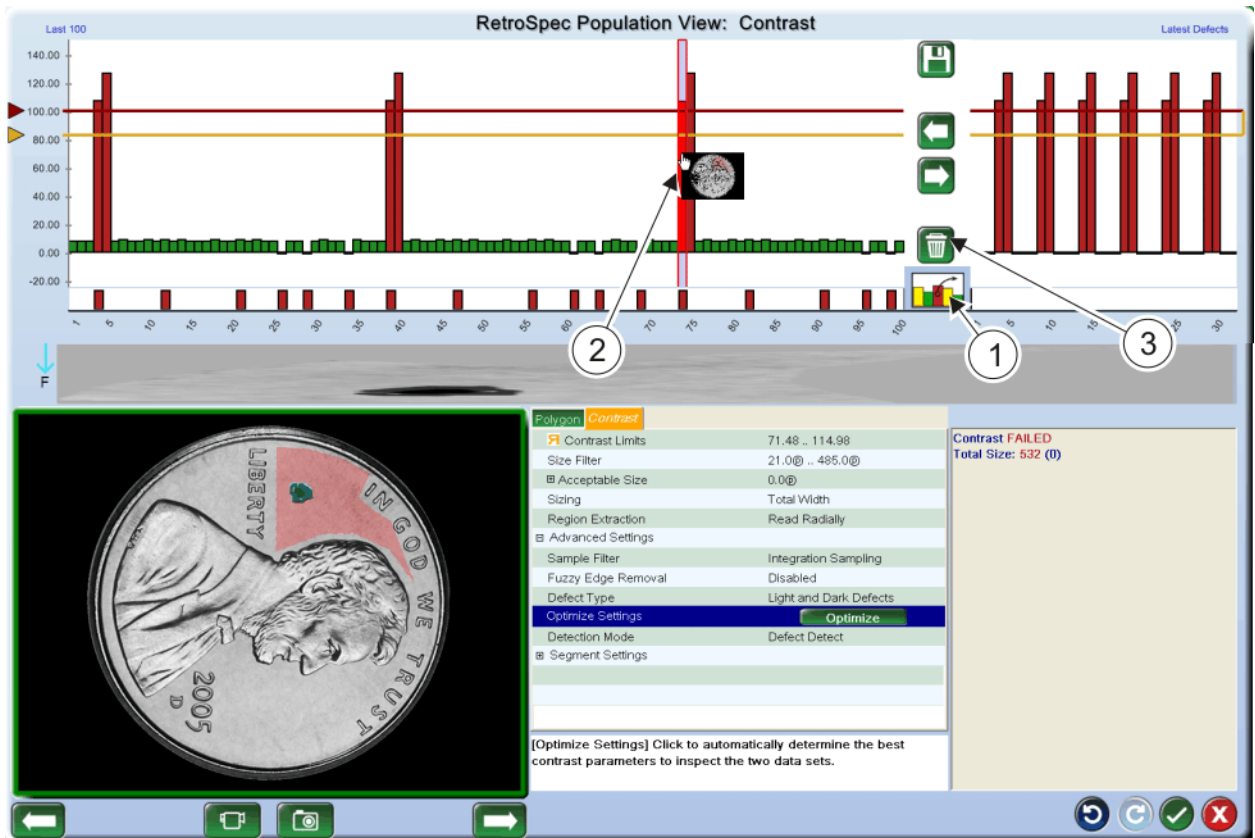

➤ **To finish setting up the Optimize feature:**

1. In the Contrast menu, choose the **Defect Type**: light, dark, or both.
2. Adjust the **Acceptable Size** parameter to catch the size of defect you want to detect.
3. Click the **Optimize** button. The system will analyze the part sets and determine the best settings to pass the good parts while failing the bad parts. Wait till the optimization process is complete - this may take several seconds.
4. Look at the Retro-Spec graph to determine whether the good parts are still passing and the bad parts are failing. Most likely, you will see a significant separation of contrast between good and bad parts.
5. Test the inspection by **loading** (see "**Loading Saved Images**" on page 163) more images. You can make slight adjustments in the Contrast menu if necessary.

## Measurement

This analysis measures an inner/outer diameter and/or width of a feature. It can be used in other types of shapes, but is most often used to measure circular features. It can find non-round (oval) parts, as well as incorrect widths of circular features.

*Series IV users: this inspection is similar to Circle Width Dimension or Retro-Spec Measurement inspection*

➤ **Before you set up the Measurement analysis:**

1. Decide which feature you want to measure: inner diameter, outer diameter, width, or all three.
2. With calipers or other measuring tools, make actual measurements on a good part. Measure at least one of the features you want to measure (inner diameter, outer diameter, and/ or width). Make a note of these measurements to input into the analysis during setup.

❖ *Note: if you choose Inspection Calibration [most common] during setup, then you only need one measurement. If you choose Feature Calibration, you will need the actual values of all the features you want to measure.*

- Place a **Region of Interest** (see "**Regions of Interest (ROI)**" on page 192) over the area you want to measure, allowing space to find edges.

❖ *Tip: If you want to measure the width of a circular feature, make the region approximately as wide as the feature on both sides. For example, if the feature is 10 pixels wide, place the region 10 pixels outside of the feature, as well as 10 pixels inside of the feature as in the example shown below.*

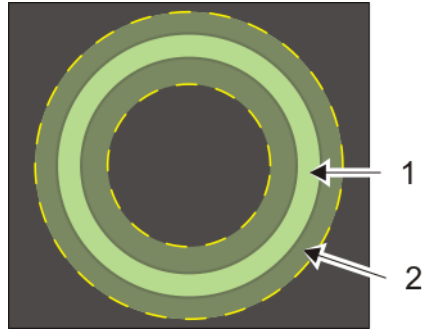

1	feature
2	region

➤ **To add a Measurement analysis:**

- Make sure a **Region of Interest** (see "**Regions of Interest (ROI)**" on page 192) has been added to the inspection tree to surround the areas you want to measure. We also recommend a **Registration** (see "**Registrations**" on page 215) before the measurement region of interest.
- Right-click on the item you just added.
- From the Inspection menu, select Add > Analysis > Measurement. The Measurement analysis is added to the inspection tree. Re-name it to something more meaningful to you.
- The Measurement menus are displayed and the region is shown on the image. (The menus are described below) Adjust the placement of the region and parameters as necessary.

➤ **To set up a basic Measurement analysis:**

- In the **Measurement** menu, pick a Feature Type [see description below].
- Choose whether to inspect for inner diameter, outer diameter, width, or all three. Under each of the corresponding menus, enable those measurements.

❖ *Note: for most applications, you can disable Range and Continuity. Leave these enabled only if required by your plant.*

- Go to the **Contrast** menu and adjust the Contrast Limits until you find an edge.
- Go to the **Measurement** menu and set most of the parameters [described below].
- Click the **Learn** button. This sets the inspection limits for the Inner, Outer, and Width measurements.
- Find the actual measurements you made on the part prior to setting up the inspection. Go to the corresponding menus (example, inner diameter = **Inner** menu). Enter these values in the Measured Distance field for each measurement (depending on Calibration Provider setting in the **Calibration** menu).
  - If you use **Inspection Calibration** [most common] for Calibration Provider, then you only need to enter one value in one of the Inner/ Outer/ or Width menus.

- If you use **Feature Calibration** for Calibration Provider, then you must enter values for all enabled measurements.
  - If you use **Sensor Calibration** for Calibration Provider and the system has already been calibrated, then skip this step.
7. Change the Units field to match your actual measurement (example, millimeters).
  8. Go to the **Calibration** menu and use the **Calibrate on Part** [recommended setting] or **Calibrate on Set** features to set the scale factor for the analysis.
  9. Set other parameters as required by your plant.

## Measurement menu

This menu provides settings that will be used in all (Inner, Outer, or Width) measurements. It also has a Learn feature that automatically sets measurement reject criteria for you.

Ring	Measurement	Inner	Outer	Width	Calibration	Contrast
Learn Settings					<b>Learn</b>	
Fuzzy Edge Removal			Disabled			
Feature Type			Light Feature			
Feature Selection Logic			Highest Contrast			
Border Sharpness			1 .. 9			
Balance			1.0			
Balance Side			Disabled			
Sample Count			36			
Allowed Gap Size			0 .. 0			

### Learn Settings

Click to learn the measurements of the part. This sets the diameter, min/max values, and average values for you and updates that information in the Inner/ Outer/ Width menus.

❖ *Note: if you make significant changes to the parameters in this menu or the other Measurement menus, click the Learn button again to update the information.*

### Fuzzy Edge Removal

This is for parts that have normal anomalies at the edges that are fuzzy, but the feature edges are sharp and clear on the image. The default is disabled. The higher the Filter Level, the stronger the fuzzy edge removal. Be aware that this filtering increases inspection time.

### Feature Type

Determine the type of feature you want the inspection to search for. Use the type that best finds the region on your part.

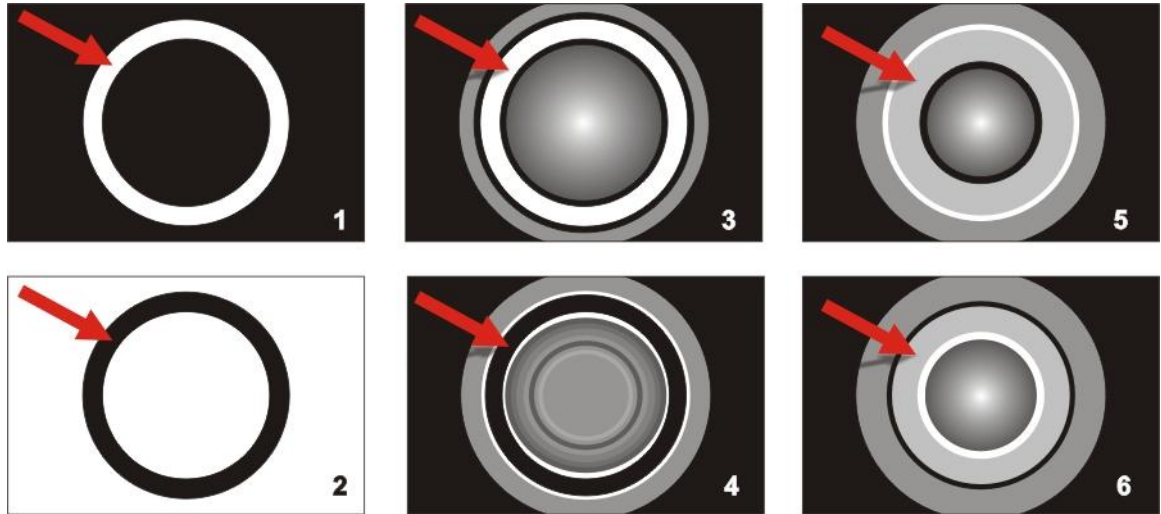

1	Light Feature
2	Dark Feature
3	Borders - both dark
4	Borders - both light
5	Borders - dark inner, light outer
6	Borders - light inner, dark outer

### Feature Selection Logic

Set this according to your part type and measurement type. Choose the type of edges you want to find for a type of feature.

❖ *Tip: for most applications, leave Border Sharpness, Balance, Balance Side, and Allowed Gap Size at their default settings.*

### Border Sharpness

For most cases, leave this set at 1 - 9. This allows you to choose whether to find sharp or gradual edges. At the default setting, the system finds both types of edges. If you only want to find sharp edges, set the values closer to one. If you only want to find gradual edges, set the values closer to nine.

## Balance

For most cases, leave this disabled. This parameter applies mostly to Feature Type = Feature. If the feature in your image is not the same gray shade across the feature, you could adjust Balance to compensate for the change in gray shade. Normally, the histogram across the feature is flat, as in illustration [a]. In the example below, the histogram for the feature of part [b] shows that the gray scale of the inner diameter is about 50% of the gray scale of the outer diameter. In this example, we would use a Balance of 0.5, and we would choose Outer for Balance Side. This allows the system to treat part [b] as though it has similar gray shades on both sides.

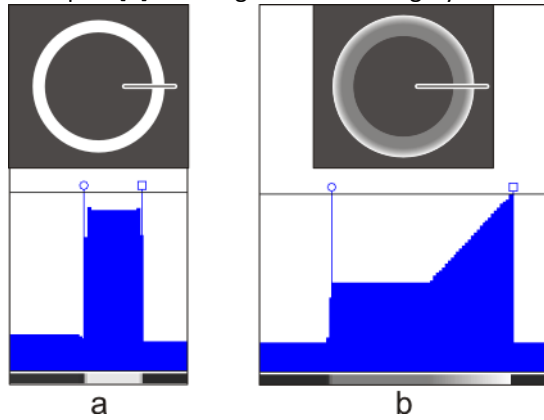

## Balance Side

When using Balance, choose which side's contrast needs to be reduced.

## Sample Count

Choose how to divide up the circle. For example, if Sample Count is 36, then the system places a search vector every  $10^\circ$  ( $360^\circ$  divided by 36 equals  $10^\circ$ ).

## Allowed Gap Size

This is used in special cases where you want to ignore a number of segments. Set this to the number of search vectors you want to ignore. For example, if Sample Count is 36, and the gap is approximately  $40^\circ$ , then the Allowed Gap Size would be four.

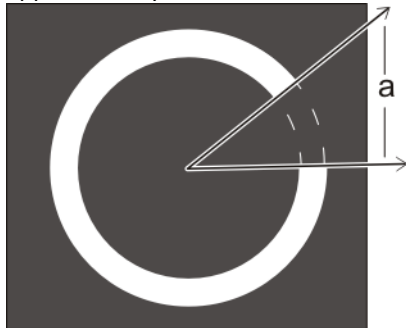

a	Allowed gap size
---	------------------

## Inner/Outer/Width menus

There are three menus to provide three different measurements. The parameters in each of the menus are the same.

Ring	Measurement	Inner	Outer	Width	Calibration	Contrast	
<input checked="" type="checkbox"/>	Inner Diameter						387.99mm
<input checked="" type="checkbox"/>	Min/Max						387.99mm +7.38mm/ -5.83mm
<input checked="" type="checkbox"/>	Average						387.99mm +2.62mm/ -3.04mm
<input checked="" type="checkbox"/>	Range						9.03mm
<input type="checkbox"/>	<input checked="" type="checkbox"/>  Continuity						+10.04mm/ -3.01 mm
	Continuity Size						3 .. 13
	Units						pixel
	Calibration Factor						0.9999
	Measured Distance						388.0mm

### Inner diameter/outer diameter/width

Check the box under the appropriate menu to perform this measurement.

❖ *Tip: When you click the Learn button in the Measurement menu, the values for Diameter/Width, Min/Max, and Average are set for you. Normally, you do not need to adjust these further.*

### Min/Max

Set the minimum and maximum allowable measurement.

### Average

Set the average measurement for the part.

❖ *Tip: for most applications, Range and Continuity are disabled.*

### Range

Set the acceptable measurement range for the part. This can be used to check for ovality. The system subtracts the minimum value found from the maximum value found.

### Continuity

This feature checks for local changes in edge position between vectors. This allows detection of defects where the part may be crushed or bent.

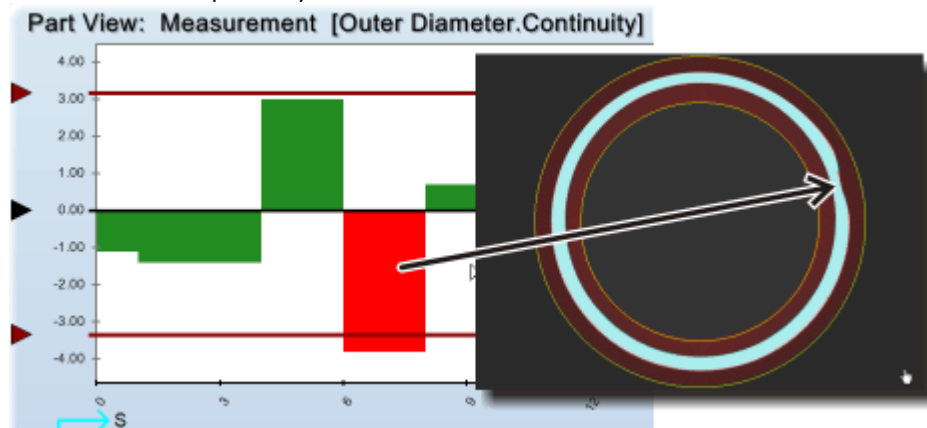

### Continuity - Size

Choose the size range of the defects you want to catch, specified in segments.

### Units

Choose your preference in the reporting of the measurements. Choose from millimeters, inches, pixels, and custom. Custom allows any calibration factor to be used.

## Measured Distance

Measure your part with calipers or another tool, then enter the actual value for Measured Distance. This is used to help calibrate the measurement.

## Calibration menu

This menu uses your actual measurements (that you input into the Measured Distance parameter) to convert the number of pixels into your preferred unit of measurement. This ensures that the system is making accurate measurements.

Ovality ROI	Measurement	Inner	Outer	Width	Calibration	Contrast
Calibration Provider		Inspection Calibration				
Dimension		Width				
Units		millimeter				
Calibrate on Part		Calibrate on Part				
Calibrate on Set A		Calibrate on Set A				
Save Calibration		Save Calibration				
Conversion Factor		1.0				

### Calibration Provider

Specify the source for the display of the calibrated values.

**Sensor Calibration** -- Calibration can be done through **Image Analysis** (on page 138), or through an inspection. When **Save Calibration** is used within an inspection, that information can be used in any other inspection (that uses Calibration Provider) for that sensor.

**Inspection Calibration** -- [most common] use the value from one of your actual measurements to calibrate the Measurement analysis. Additional **Dimension** and **Units** parameters are available to choose one of your measurements and preferred unit of measurement. Additionally, **Conversion Factor** can be adjusted manually to get the best match between pixels and physical length.

**Feature Calibration** -- use separate calibration settings for each of the enabled measurements (inner diameter, outer diameter, or width). You must enter an actual measured value into each of the appropriate menus.

### Dimension

[Available when Calibration Provider = Inspection Calibration] Specify which dimension to use to calibrate the inspection.

### Units

Choose your preference in the reporting of the measurements. Choose from millimeters, inches, pixels, and custom. Custom allows any calibration factor to be used.

### Calibrate on Part

Use the current image to calibrate the Measurement analysis. Use a known good part.

### Calibrate on Set A

Use the current set of images in Set A to calibrate the Measurement analysis. The system takes the average value of the set and uses that number to calibrate the analysis.

### Save Calibration

Click the **Save Calibration** button to save the calibration scale and units to the sensor for use by other inspections.

### Conversion Factor

This indicates the pixel size and is used to convert one pixel into the units selected. The initial conversion will be controlled by the Learn Calibration results. You can adjust this value manually if necessary.

## Contrast menu

This menu allows you to adjust for sensitivity and defect size for the inspection.

Ring	Measurement	Inner	Outer	Width	Calibration	<b>Contrast</b>
Contrast Limits				113.57 .. 153.88		
Size Filter				1.0mm .. 514.0mm		

### Contrast Limits

Set the sensitivity of the inspection. You can also move the red and yellow bars on the Retro-Spec graph by selecting the arrows to the left of the graph.

### Size Filter

Choose a feature size you want to measure. For example, you may want to ignore very small features but find larger ones. For example, if Size Filter is set to 3 -- 80, any feature smaller than three pixels or larger than 80 pixels would be ignored.

## Results window

The results displayed for a measurement inspection are different than other inspections. In addition to the parameters, a measurements table is displayed.



Measurement PASSED  
Metric Values:  
Feature Contrast = 87.6

	Inner	Outer	Width
Min	432.68	439.84	2.93
Max	439.44	446.73	6.01
Avg	436.00	443.81	3.91
Range	6.76	6.90	3.08
Continuity Lo	-3.00	-2.90	-1.80
Continuity Hi	2.90	2.70	2.20
Contrast	87.6		

You can perform several functions through this results window, including:

- Go directly to the parameters to adjust a particular measurement. If you click the [6.01] in the example, the Width menu is displayed and the Min/ Max parameter is highlighted for you.
- View the corresponding Retro-Spec graph. If you click [6.01] under Width in the example, the Width Min/ Max graph is displayed at the top of the screen.

More options are available when you right-click over this window to see the **Measurement Results** menu. This menu allows you to enable or disable an entire measurement set such as Inner, Outer, or Width. If you click "Enable/ Disable Measure," then the parameter you right-clicked to see this menu becomes enabled or disabled.

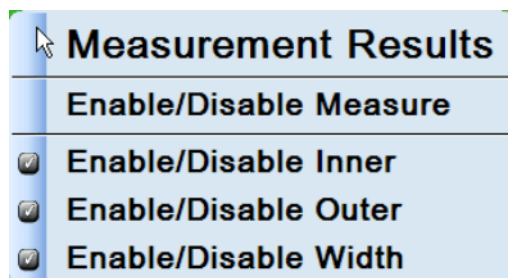

## Fill Height

Fill Height inspection is used for determining the fill level of containers, mainly to find containers with high fill or low fill. The Fill Height inspection compares the fill level of the liquid to a standard reference point, which is typically the neck ring of a container.

❖ *Notes: This inspection requires a **Measure ROI** (on page 198) Region using two regions.*

The example below shows a bottle with a normal fill height [item 1], and a bottle with a fill height that is too low [item 2].

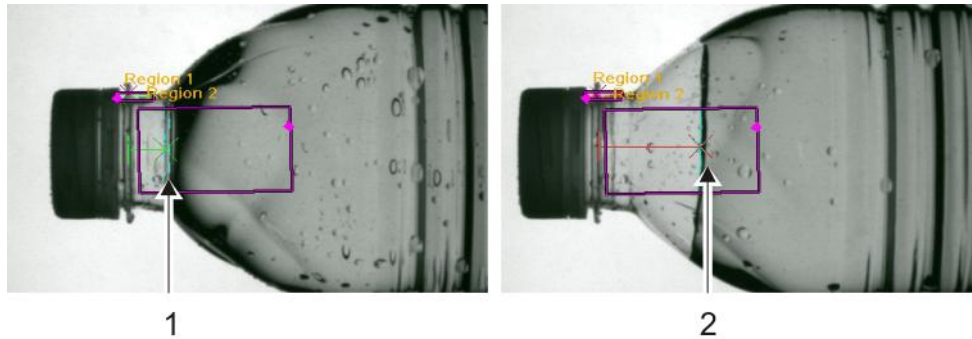

1	Normal fill height
2	Fill height too low

### ➤ *To add a Fill Height inspection:*

1. Make sure a **Measure ROI** (on page 198) Region of Interest has been added to the inspection tree. Suggested settings are as follows:
  - a) In the Measure ROI menu, set Region Count to Two Regions.
  - b) Place Region One over a distinct reference point, such as the neck ring.
  - c) Place Region Two over a section of the bottle where you expect to see the liquid level. An example is shown below.
  - d) Save and close the Measure ROI region menu.

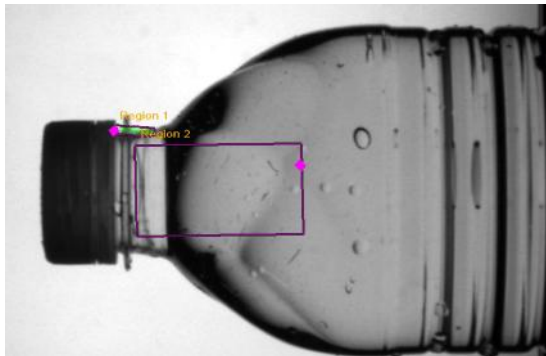

2. Highlight the region name in the inspection tree.
3. Right-click on the name of the region you just added.
4. From the Inspection menu, select Add > Analysis > Fill Height. The analysis is added to the inspection tree. Re-name the inspection to something more meaningful to you.
5. The Fill Height menus are displayed and the regions are shown on the image. (The menus are described below) Adjust the placement of the regions and parameters as necessary.

## Fill Height menu

❖ Note: The symbol [Ⓢ] indicates that this value is in pixels. Your system may show [mm] for millimeters, ["] for inches, or [ ] blank for custom units. It indicates that this value can be calibrated using **Review Camera Calibration** (on page 144) or **Image Analysis** (on page 138) for the current sensor.

Fill Height RO	Fill Height	Reference	Fill Top	Calibration
Fill Mode			Top Only	
Part Orientation			Closure on Left	
Reference Region			Region 1	
Correct Fill Position			<input checked="" type="checkbox"/> Enabled	
Fill Correction Deviation			30.0Ⓢ	
<input checked="" type="checkbox"/> Fill Height Limits			29.0Ⓢ +/-29.0Ⓢ	
Nominal			29.0Ⓢ	
Show Fill Height			<input checked="" type="checkbox"/> Enabled	

### Fill Mode

Choose whether to measure fill level at the Top Only or at the Top and Bottom

**Top Only** is generally used for water or other non-carbonated beverages.

**Top and Bottom** is used mainly for carbonated beverages, or beverages that foam when the liquid sloshes around in the container as it moves in front of the inspection module. The inspection can measure the distance from the reference point to the top of the foam, and also from the reference point to the bottom of the foam.

### Part Orientation

Choose the orientation of your part. In many cases, the part image is sideways to optimize the inspection area on the screen.

### Reference Region

Choose a region from the Measure ROI region of interest to set as the reference point (in our setup example, we picked Region 1). A typical setup uses the neck ring of a bottle as the reference region. The direction of the search is determined in the region setup (search towards the diamond). You can change search direction by right-clicking over the image and using the choices from the **Image Options** (on page 164) menu.

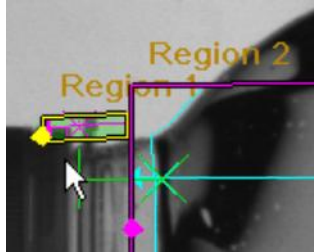

### Correct Fill Position

Enables edge correction, where the system uses a "moving average" technique to eliminate outlying edges (example: edges caused by water spots or bubbles in the liquid).

### Fill Correction Deviation

[Available when Correct Fill Position is enabled] This is used to correct stray points that fall too far away from the moving average edge position. The value is in pixels. Make sure you use a high enough value, or the inspection will not properly detect sloshing liquid. A common value to use is 25 or higher.

### Fill Height Limits

Define the valid fill height range per your specifications. This value is measured with respect to your reference point (the neck ring, in our example). You can use the bars on the Retro-Spec graph to adjust the limits.

## Nominal

The ideal fill height value.

## Show Fill Height

Show the fill height measurement on the image.

## Reference menu

Fill Height RO	Fill Height	Reference	Fill Top	Calibration
Vector Spacing			1	
Max Missed Edges			6	
Edge Polarity			Light-to-Dark	
Edge Gradient			70 .. 255	
Edge Size			2	
Edge Thickness			1	
Edge Delta			3	
Show Edges			<input checked="" type="checkbox"/> Enabled	
Show Vectors			<input type="checkbox"/> Enabled	
Show Search Direction			<input type="checkbox"/> Enabled	

Set the parameters to find the edges in the reference region.

### Vector Spacing

The distance between search vectors.

### Max Missed Edges

The number of search vectors that are allowed to fail without causing the inspection to fail.

### Edge Polarity

Choose the type of edge to search for – Light to Dark, Dark to Light, or Either. For example, if the feature you want to find is very bright, choose Dark to Light.

### Edge Gradient

The minimum and maximum difference in gray shades, between two pixels, to be considered an edge.

### Edge Size

Indicates how many pixels in a row to compare (1 to 1, 2 to 2, etc.). The larger the Edge Size, the stronger the edge will need to be. This parameter acts like a filter that looks at a length in pixels before and after the edge.

### Edge Thickness

The number of consecutive times that the gradient must be met to define an edge.

### Edge Delta

The distance between pixels being compared when seeking an edge. A higher Delta value is more sensitive because it finds more edges.

### Show Edges

Show the found edges on the image.

### Show Vectors

Show the search lines on the image.

### Show Search Direction

Show the search direction of the vectors with an arrow.

## Fill Top or Fill Bottom menu

Fill Height RO	Fill Height	Reference	Fill Top	Calibration
Vector Spacing			1	
Search Direction			<input type="checkbox"/> Flipped	
Max Missed Edges			95	
Edge Polarity			Light-to-Dark	
Edge Gradient			5 .. 45	
Edge Size			2	
Edge Thickness			1	
Edge Delta			1	
Show Edges			<input checked="" type="checkbox"/> Enabled	
Show Vectors			<input type="checkbox"/> Enabled	
Show Search Direction			<input type="checkbox"/> Enabled	

Set the parameters to find the edges for the fill level top (Fill Top menu) or the fill level bottom (Fill Bottom menu).

### Vector Spacing

The distance between search vectors.

### Search Direction

Change the search to the opposite direction.

### Max Missed Edges

The number of search vectors that are allowed to fail without causing the inspection to fail.

### Edge Polarity

Choose the type of edge to search for – Light to Dark, Dark to Light, or Either. For example, if the feature you want to find is very bright, choose Dark to Light.

### Edge Gradient

The minimum and maximum difference in gray shades, between two pixels, to be considered an edge.

### Edge Size

Indicates how many pixels in a row to compare (1 to 1, 2 to 2, etc.). The larger the Edge Size, the stronger the edge will need to be. This parameter acts like a filter that looks at a length in pixels before and after the edge.

### Edge Thickness

The number of consecutive times that the gradient must be met to define an edge.

### Edge Delta

The distance between pixels being compared when seeking an edge. A higher Delta value is more sensitive because it finds more edges.

### Show Edges

Show the found edges on the image.

### Show Vectors

Show the search lines on the image.

### Show Search Direction

Show the search direction of the vectors with an arrow.

## Empty/ Full menu

Ribbon	Fill Height	Reference	Fill Top	Empty / Full	Calibration
<b>Empty / Full Check</b>				<input checked="" type="checkbox"/>	<b>Enabled</b>
Ambient Technique				Density	
Ambient Threshold				80.0	
Ambient Analysis Mode				Min & Max	
<input type="checkbox"/> Ambient Limits				128 +127/ -128	
Nominal				128	

Use this check to determine whether the bottle is empty or full. The system performs an ambient check in the Fill Height region to determine whether the bottle is empty or full.

### Ambient Technique

This method determines the region's ambient. Choose the method through the drop-down menu.

- **Max Amplitude** looks for the maximum gray level amplitude — the gray level with the most pixel counts — within the histogram of the search area.

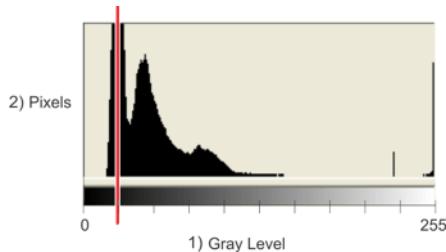

1	Gray level
2	Pixels in the histogram of the image

**Peak Percentile** locates the gray level value that exceeds the **threshold**. In the example below, the system would use the gray level to the right of the line marking 80%.

- **Ambient Threshold** defines what percentage of the search area to use.

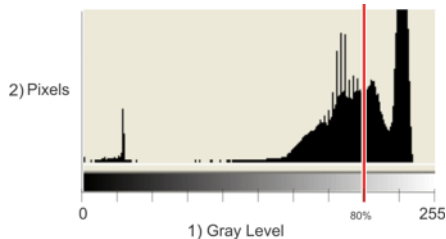

1	Gray level - choose a percentage
2	Pixels in the histogram of the image

- **Density** computes the average of all the pixel gray levels — total gray level divided by pixels.

### Ambient Analysis Mode

Specify the reject criteria.

**Min & Max** - The minimum and maximum acceptable ambient gray level values. Any computed ambient found lower than or greater than these values will cause the inspection to fail.

**Min Only** - The minimum acceptable ambient gray level value. Any computed ambient found lower than this value will cause the inspection to fail.

**Max Only** - The maximum acceptable ambient gray level value. Any computed ambient found greater than this value will cause the inspection to fail.

### Ambient Limits

The minimum and maximum acceptable ambient gray level values. Any computed ambient found lower than or greater than these values will cause the inspection to fail.

### Nominal

The expected gray level value of the region of interest.

## Calibration menu

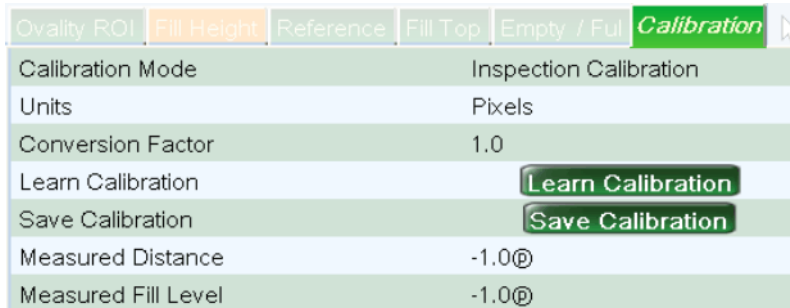

Ovality ROI	Fill Height	Reference	Fill Top	Empty / Full	Calibration
Calibration Mode		Inspection Calibration			
Units		Pixels			
Conversion Factor		1.0			
Learn Calibration		<input type="button" value="Learn Calibration"/>			
Save Calibration		<input type="button" value="Save Calibration"/>			
Measured Distance		-1.0@			
Measured Fill Level		-1.0@			

Set the parameters to convert pixel measurement into your preferred measurement unit.

### Calibration Mode

The system will convert the pixel dimensions into your preferred unit of measurement.

**Sensor Calibration** -- Use the calibration previously set up for the sensor through *Image Analysis* (on page 138) or through another inspection.

**Inspection Calibration** -- Use the calibration from this inspection only.

### Units

Choose your preference in the reporting of the measurements. Choose from millimeters, inches, pixels, and custom. Custom allows any calibration factor to be used.

### Conversion Factor

This indicates the pixel size and is used to convert one pixel into the units selected. The initial conversion will be controlled by the Learn Calibration results. You can adjust this value manually if necessary.

### Learn Calibration

Click the **Learn Calibration** button to automatically determine the scale factor, which converts the value to the desired units.

### Save Calibration

Click the **Save Calibration** button to save the calibration scale and units to the sensor for use by other inspections.

### Measured Distance

Measure your part with calipers or another tool, then enter the actual value for Measured Distance. This is used to help calibrate the measurement.

### Measured Fill Level

Measure your part's normal fill level (with respect to the bottom of the bottle) with calipers or another tool, then enter the actual value for Measured Fill Level. This is used to help calibrate the measurement.

## Measure Extract

This analysis will use edge search criteria to find the minimum, maximum, and average edge location in a Measurement ROI. You then add a Dimension - **Distance** (on page 287) inspection to do the measurement of the found feature position.

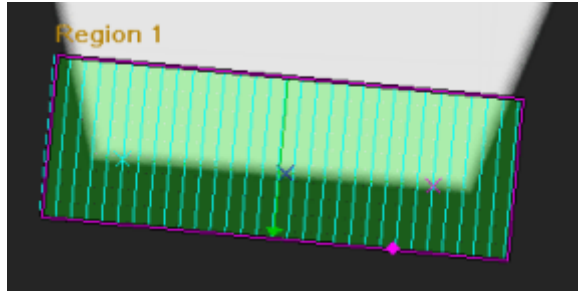

### ➤ To add a Measure Extract analysis:

1. Make sure a **Measure ROI** (on page 198) Region of Interest has been added to the inspection tree. Make sure the region is placed over the feature(s) you want to measure.
2. Right-click on the item you just added.
3. From the Inspection menu, select Add > Analysis > Measure Extract. The Measure Extract analysis is added to the inspection tree. Re-name it to something more meaningful to you.
4. The Measure Extract menu is displayed and the region is shown on the image. (The menu is described below) Adjust the placement of the region and parameters as necessary.

### Measure Extract menu

Measure ROI(s)	Measure Extract
Vector Spacing	10
✎ Max Missed Edges	18
Edge Polarity	Light-to-Dark
Edge Gradient	86 .. 139
Edge Size	2
Edge Delta	2
Enhance Vectors	<input type="checkbox"/> Enabled
Show Edges	<input checked="" type="checkbox"/> Enabled
Show Vectors	<input checked="" type="checkbox"/> Enabled
Show Search Direction	<input checked="" type="checkbox"/> Enabled
Show Measurement Positions	<input checked="" type="checkbox"/> Enabled

#### Vector Spacing

The distance between search vectors.

#### Max Missed Edges

The number of search vectors that are allowed to fail without causing the inspection to fail.

#### Edge Polarity

Choose the type of edge to search for – Light to Dark, Dark to Light, or Either. For example, if the feature you want to find is very bright, choose Dark to Light.

#### Edge Gradient

The minimum and maximum difference in gray shades, between two pixels, to be considered an edge.

#### Edge Size

Indicates how many pixels in a row to compare (1 to 1, 2 to 2, etc.). The larger the Edge Size, the stronger the edge will need to be. This parameter acts like a filter that looks at a length in pixels before and after the edge.

**Edge Delta**

The distance between pixels being compared when seeking an edge. A higher Delta value is more sensitive because it finds more edges.

**Enhance Vectors**

Computes an average pixel value from a neighborhood of 3x3 pixels around each pixel of the vector.

**Show Edges**

Show the found edges on the image.

**Show Vectors**

Show the search lines on the image.

**Show Search Direction**

Show the search direction of the vectors with an arrow.

**Show Measurement Positions**

Show the location of the measurement positions (minimum, maximum, and average).

## Distribution

The Distribution inspection looks at color printing on parts, detecting 'tramp cans' or gross decoration errors on parts. If you are familiar with the Pressco Extractor product, the Distribution inspection will seem familiar to you.

This inspection can also inspect for proper color of a product. For example, if you are inspecting blue preforms, it can detect when a preform is not the proper color blue, or if it is an incorrect color.

The Distribution inspection can inspect for gross decorator defects in gray scale images or color images. Use Gray Scale mode if your system does not have a color camera, or you want to focus on a specific range of gray shades. This can help detect scratches or other defects where the color is missing from an area on the part.



The inspection uses:

- A learned data set to compare to newly inspected parts
- **Color histograms** (see "**Distribution Histogram Types**" on page 281) that consist of a number of color bins. Each color in the region of interest is analyzed. The total number of pixels containing a certain color (or gray scale) are counted and placed in each bin.

### ➤ **To add a Distribution analysis:**

1. Make sure a Region of Interest has been added to the inspection tree.
2. Right-click on the item you just added.
3. From the Inspection menu, select Add > Analysis > Distribution. The analysis is added to the inspection tree. Re-name the inspection to something more meaningful to you.
4. The Distribution menu is displayed and the region is shown on the image. (The menu is described below) Adjust the placement of the region and parameters as necessary.

### **Load a set of good images into Data Set A**

You can use images of the last parts run (up to 100 parts) and learn using this data. However, you must make sure that all the images in the data set are from good parts. You can look at the Population View graph and delete the images you do not want. Alternately, you can load a set of known good images that you have saved previously using the steps below.

### ➤ **To load Data Set A:**

1. Look at the **Retro-Spec Population View Graph** (on page 185).

- Click the left arrow  button on the Retro-Spec graph to view the **Select Data Sets** menu.

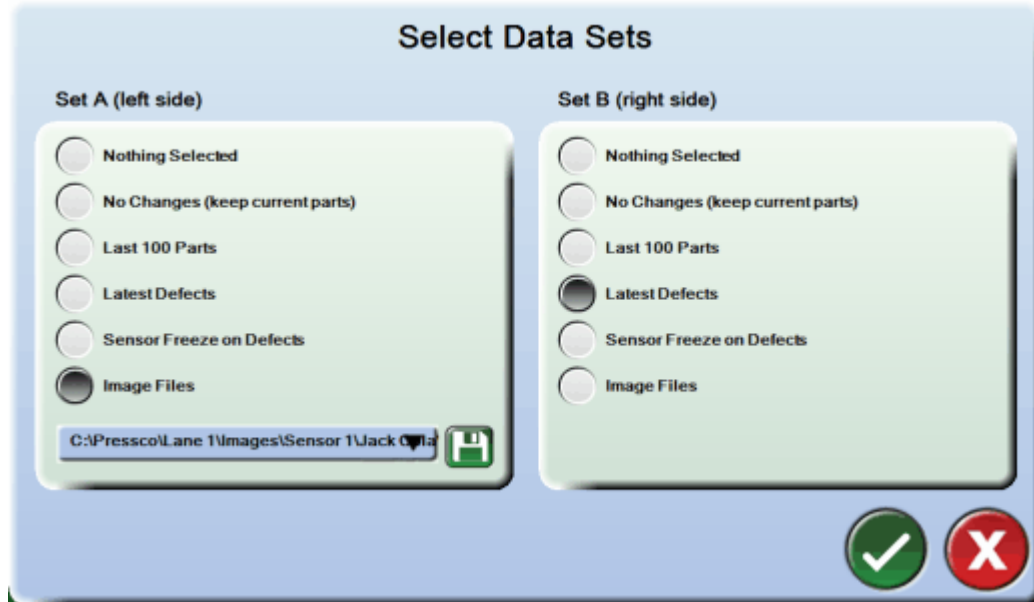

- Click the Image Files button for Set A.
- Click the disk icon  to browse to the folder where the images were saved. The **Select File** menu is displayed.

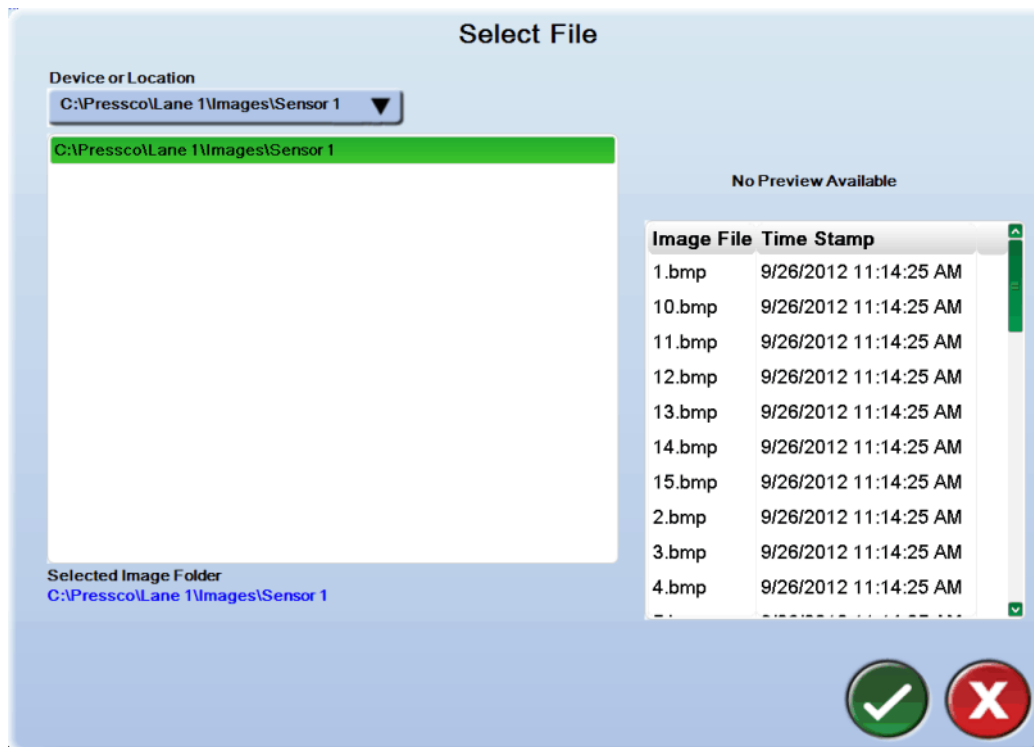

- Browse to and select the folder that contains the images you want to load.
- Click the OK button  in the Select Location and Select Data Sets menus to load all the bitmap images that were previously saved in the selected folder.

## Set up the Distribution inspection

### ➤ To set up a Distribution inspection:

1. Make sure a good set of images is loaded into Data Set A (see above).

❖ *Note: descriptions of the parameters mentioned are described under the Distribution menu section below.*

2. Choose a different **Histogram Type** if appropriate for your part.
3. Use the **Learn** function.
4. Set the Attenuation if desired.
5. Use the **Learn More** function if desired.

❖ *Note: To use the Learn More function, you will need a set of part images in Data Set A. The images can be the last 100 parts you have inspected, or images from a file. To load more images, use the instructions to "Load a set of good images into Data Set A" listed above.*

## Distribution menu

Ring	Distribution
Histogram Type	New RETRO-SPEC Color Hist..
Gray Scale	0 .. 255
Bin Count	255
Deviation Limits	+20.0/ -20.0
Attenuation	0
Learn	<input type="button" value="Learn"/>
Learn More	<input type="button" value="Learn More"/>
Region Extraction	Read Radially
Color Mode	Gray Scale

### Histogram Type

Select one of the **Distribution Histogram Types** (on page 281). This is *not* used if **Color Mode** = Gray Scale.

### Gray Scale

Specify the range of gray scales for the distribution inspection. This is *not* used if **Color Mode** = RGB.

### Bin Count

This is only used when **Color Mode** = Gray Scale. Set the number of bins (gray shades) the histogram is divided into. Note that some constraints may apply, and this number may not exactly match the number of bins.

### Deviation Limits

Set the tolerance level for the colors or gray scale values. Positive values represent too much of some color. Negative values represent too little of some color. The values correspond to the largest deviations of some color from its expected amount, which is determined when learning the data set. Values of zero represent no deviation of color.

### Attenuation

Set the minimum number of pixels of a color or gray shade that must be seen before they are counted. For example, if Attenuation is set at 100, there must be at least 100 pixels of that color or gray shade, or it will be ignored. Increasing attenuation reduces sensitivity to small changes. It ensures that only significant color changes cause the product to fail.

## Learn

The inspection needs to learn the colors or gray shades of your product. To learn, the inspection looks at the samples in Data Set A. Therefore, you will need a set of images in Data Set A. The data set should contain a good sample of your production line. Ideally, you should store the images of about 100 good parts in Data Set A. The larger the sample population, the better the inspection results.

- ❖ *Note: if there are any defective parts in Data Set A, they will be included in the learned data. Therefore, you might want to look through the data set using the Comparison View graph, and move defective parts to Data Set B.*
- ❖ *Note: Learn overwrites existing data. It can be used if you are testing the inspection on a new part, or want to clear the data from a previous learn.*

## Learn More

[Only available after you use Learn] - After you have used the Learn function, you can add to the learned data. Use this to learn new parts where the colors might be slightly different than your original data set, but are still good parts. This builds a wider tolerance of colors for your parts. This feature can be used at any time - for example: immediately after the initial learn, or several weeks later.



## Region Extraction

Choose how the Intellispec should read the information from the region. This usually depends on the shape of your region.

- ❖ *Note: some inspections do not use all of these options*

The illustration below shows how the information is read by each method. Note that these shapes are examples only - your region does not have to match the shape.

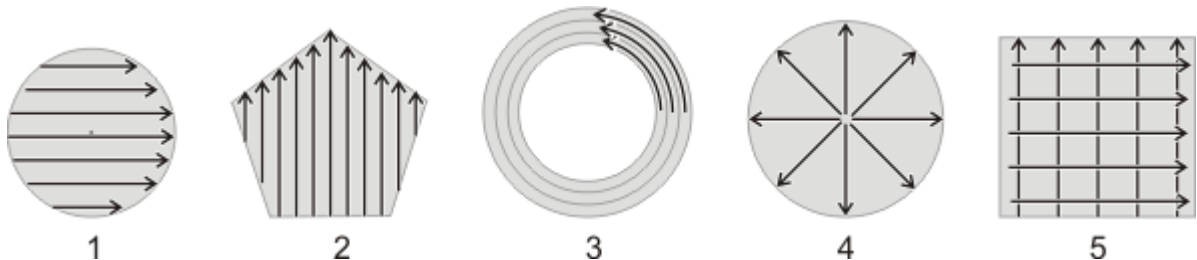

1	<b>Read Horizontally</b> - Extract the region horizontally - 90 degrees with respect to orientation.
2	<b>Read Vertically</b> - Extract the region vertically - parallel with respect to orientation.
3	<b>Read Circularly</b> - Extract in a circular fashion around the region.
4	<b>Read Radially</b> - Extract region in a radial direction.
5	<b>Read Horizontally and Vertically</b> - Extract the region both horizontally and vertically (with respect to orientation). This is used in special cases.

## Color Mode

Choose whether to extract the data in Gray Scale or RGB mode. Note that your system must have a color camera to use RGB mode.

## Information about the graphs in Distribution inspection

The Part View graph view shows the distribution of the color of pixels in the inspection's region of interest. Each bar on the graph represents a number of pixels in each color bin. The color bins are shown in the color band at the bottom of the graph. For information about the color bins, refer to **Distribution Histogram Types** (on page 281).

The example below shows a Part View graph with a good part (top) and a defective part (bottom). The defective part had too many pixels of several different colors in this example - possibly a 'tramp' part.



### Distribution Histogram Types

In the **Distribution** (on page 276) inspection, there are several color histograms available. Most often, you will be using the New Retro-Spec Color Histogram. You will notice the difference between the histograms in the color bar directly below the **Retro-Spec Part View Graph** (on page 188).

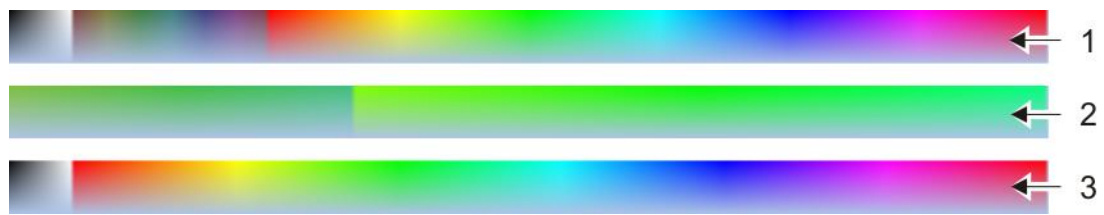

1	New Retro-Spec Color Histogram
2	Special Color Histogram (Chartreuse, Green, Spring Green shown)
3	Classic Extractor Histogram
4	White Level Histogram - not shown

➤ **To see a different histogram:**

1. Select a different from the **Histogram Type** drop-down menu.
2. Switch to Population View on the graph by right-clicking the Retro-Spec graph, then selecting Population View from the Retro-Spec Options menu.
3. Switch to Part view by right-clicking on the Retro-Spec graph, then selecting Part View from the Retro-Spec Options menu. The new histogram is displayed below the graph.

## New Retro-Spec Color Histogram

In this histogram, there are 16 bins of gray scale, 48 bins of dark or pastel colors, and 192 bins of very bright colors. The 48 bins of dark or pastel colors have a wider tolerance, and therefore you may see most of the colors of your part in those bins. This histogram also has some overlapping of colors - that is, pixels may be mapped to more than one color bin. This ensures that slight variations of color do not cause the product to fail.

## Special Color Histograms

In special cases, you may use other color histograms. The color bars are viewable under the Part View graph.

If you are trying to detect off-color parts, such as preforms, use one of the special color histograms. For example, if your preforms are supposed to be green, use the histogram that most closely matches the correct color. This provides a large range of green colors to be detected. When a different color part (blue, for example) goes through your product stream, that part will be easily detected because it will not fall into the learned green color range.

## Classic Extractor Histogram

This histogram is the same as the original Pressco Extractor product. It has 16 gray scale bins and 240 color bins. This is different from the New Retro-Spec Color Histogram in that it does not have the middle section of 48 bins of dark or pastel color.

This histogram is only used when an approximate comparison between the original Extractor product and the Retro-Spec Distribution is required.

## White Level Histogram

(As of this printing, the white level histogram is not displayed under the Retro-Spec graph)

This histogram is used for pastel colors, or if you want to differentiate between shades of the same color. For example, you might need to detect when a yellow color is too light compared to the normal yellow shade.

## Label Skew Extract

Label Skew Extract is similar to **Measure Extract** (on page 275). Label Skew Extract is specialized to locate the edge of the label and can be set up for either one or two search regions. It finds the edges of a label and draws a "best fit" line using those edges. The inspection's main function is to export this data to a Dimension > Angle inspection. Label Skew Extract inspection can reject a part if the label is not consistent enough, such as a flagged label.

Label Skew requires a **Measure ROI** (on page 198) to set up the region(s). The actual skew inspection is handled by the **Angle** (on page 291) dimension.

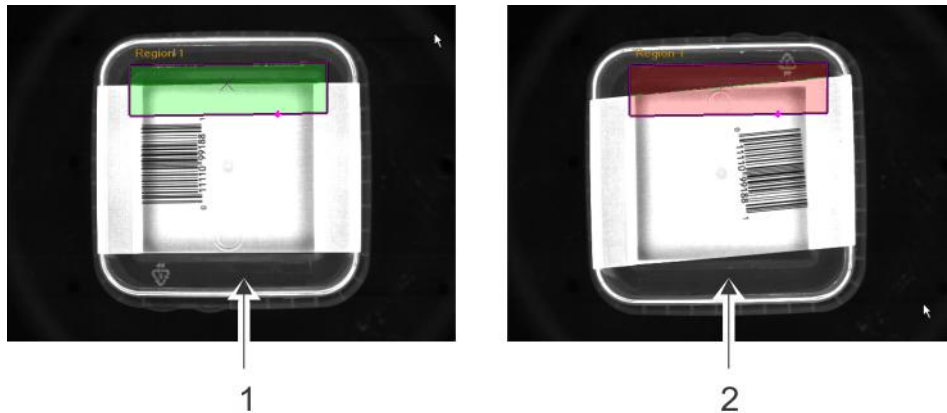

1	Normal label
---	--------------

➤ **To add a Label Skew Extract inspection:**

1. Make sure a **Measure ROI** (on page 198) Region of Interest has been added to the inspection tree. Set up the Measure ROI for one or two regions.
2. Right-click on the item you just added.
3. From the Inspection menu, select Add > Analysis > Label Skew Extract. The analysis is added to the inspection tree. Re-name the inspection to something more meaningful to you.
4. The Label Extract and Region menus are displayed and the region is shown on the image. (The menus are described below) Adjust the placement of the region and parameters as necessary.
5. After setting up the Label Skew extract, add an **Angle** (on page 291) dimension.

## Label Skew Extract menu



### Check Consistency

Enable the consistency check (the label skew check).

### Label Consistency

Set up the limits for the position of the found edges. This number indicates the straightness of a line. A lower number means the points do not deviate much from a straight line and is therefore more consistent.

## Region 1 menu

Set the parameters so that desired label edges are found. Note that search direction and region position can be set by using the **Image Options** (on page 164) menu. Right-click over the image to see the Image Options menu.

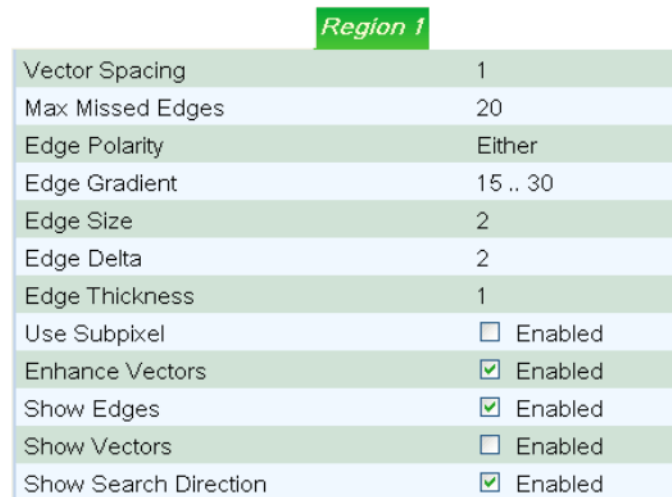

### Vector Spacing

The distance between search vectors.

### Max Missed Edges

The number of search vectors that are allowed to fail without causing the inspection to fail.

### Edge Polarity

Choose the type of edge to search for – Light to Dark, Dark to Light, or Either. For example, if the feature you want to find is very bright, choose Dark to Light.

### Edge Gradient

The minimum and maximum difference in gray shades, between two pixels, to be considered an edge.

### Edge Size

Indicates how many pixels in a row to compare (1 to 1, 2 to 2, etc.). The larger the Edge Size, the stronger the edge will need to be. This parameter acts like a filter that looks at a length in pixels before and after the edge.

### Edge Delta

The distance between pixels being compared when seeking an edge. A higher Delta value is more sensitive because it finds more edges.

### Edge Thickness

The number of consecutive times that the gradient must be met to define an edge.

### Use Subpixel

Finds edges based on their subpixel location, rather than rounding off to the nearest pixel. This gives greater centering accuracy.

### Enhance Vectors

Computes an average pixel value from a neighborhood of 3x3 pixels around each pixel of the vector.

### Show Vectors

Show the search lines on the image.

### Show Search Direction

Show the search direction of the vectors with an arrow.

## Feature Detect

Feature Detect analysis can be used to detect a range of specific gray shades to determine defects. For example, in a fill height/ cap placement inspection, it can be used on the cap to determine whether a tamper band is broken.

❖ *Note: Feature Detect analysis requires either a **Ring Region** (on page 193) or **Polygon Region** (on page 194) of interest.*

*Series IV users: Feature detect is similar to Zones Inspection.*

### ➤ **To add a Feature Detect analysis:**

1. Make sure a **Ring Region** (on page 193) or **Polygon Region** (on page 194) of interest is already added to the inspection tree. Adjust the region to examine the area of interest where you will place the Feature Detect inspection.
2. Right-click in the inspection tree to see the Inspection menu.
3. From the Inspection menu, select Add > Analysis > Feature Detect. The analysis is added to the inspection tree. Re-name it to something more meaningful to you.
4. The Feature Detect menus are displayed and the region is shown on the image. (The menus are described below) Adjust the placement of the region and parameters as necessary.

## Feature Detect menu

Use the Feature Detect menu to specify a range of gray shades to find.

Polygon		Feature Detect	
Feature Method		Use Qualified Features	
Feature Gray Scale		114 .. 255	
Feature Size		15 .. 307200	
Show Features		<input checked="" type="checkbox"/> Enabled	
Show Feature Centers		<input checked="" type="checkbox"/> Enabled	
<input type="checkbox"/> <input checked="" type="checkbox"/> Check Feature Area			
<input type="checkbox"/>  Allowed Area		0 +75/- 0	
Nominal		0	
Learn Nominal Area		<input type="button" value="Learn"/>	
<input type="checkbox"/> <input checked="" type="checkbox"/> Check Feature Count			
Allowed Feature Counts		0 .. 100	

### Feature Method

Choose a method to determine the ambient value in a search region.

**Use All Data** - Analyzes all the pixels in the search region, and counts the total number of pixels that meet the criteria set in **Feature Gray Scale**.

**Use Qualified Features** - Analyzes all the pixels in the search region, but only counts pixels if:

- The pixels meet the **Feature Gray Scale** criteria, AND
- The pixels meet the **Feature Size** criteria.

### Feature Gray Scale

Set the range of gray shades of the feature you want to locate.

### Show Features

Highlight the found features on the image.

### Check Feature Area

Check the area of the feature to see that it is within the specified tolerance.

### Allowed Area

[only available if Check Feature Area is enabled] The tolerance (in pixel area) of the feature you want to locate.

### Nominal

The expected area size. This number is populated when you press the **Learn** button.

### Learn Nominal Area

Click the **Learn** button to automatically learn the area.

### Check Feature Count

Check to see that the correct number of features is found.

The following parameters are available when **Feature Method = Qualified Features**.

### Feature Size

Set the allowable size of the feature you want to locate.

### Show Feature Centers

Show the center points of the found features, marked with an 'X.'

## ***Feature Detect - example FHCP 3X***

The example below shows where a Feature Detect inspection could be used within a Fill Height/ Cap Placement inspection. It could be used to detect a defective tamper band. This tamper band did not meet tolerance criteria for gray scale range, so it failed inspection.



# Dimensions

The dimension inspection type is special in that it connects the results of two other inspections to do the analysis. For example, a distance inspection can connect two registrations to measure the distance between centers of two features.

The Dimension inspections include:

- **Distance** (on page 287)
- **Angle** (on page 291)

❖ *Note: Your system (and this book) may show only those items that apply to your application.*

## Distance

The Distance inspection computes the distance between two points. This is useful if you want to find features that are out of tolerance or out of place on a part. Distance inspection does NOT use a region. It obtains information produced in other inspections. The other inspections can include a Registration (it uses the found registration point), or a Measure Extract inspection.

*Series IV users: this inspection produces the same results of Dimension inspection, but in Series V the measurement points are found by other inspections.*

Examples of where Distance inspection might be used is for detecting swung gates or high caps on bottles, turned tabs on converted or EZO ends, or computing finish dimensions. The example below shows a gate position computed with respect to the center of the base.

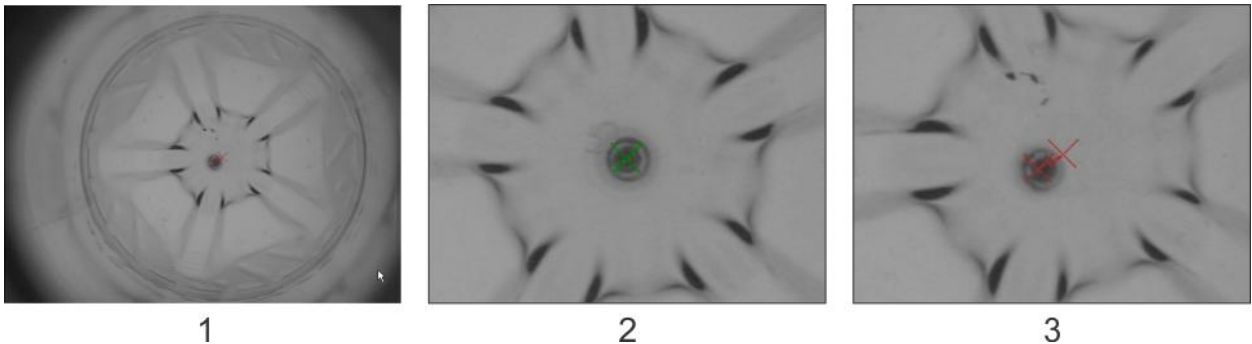

1	Full image with swung gate
2	Enlarged image of good part
3	Enlarged image of bad part showing incorrect position of gate

Distance can be computed with respect to the center of the screen, if desired.



### ➤ **To add a Distance measurement:**

1. Make sure at least one **Registration** (see "**Registrations**" on page 215) or **Measure Extract** (on page 275) inspection is placed in the inspection tree. To find the distance between two points, place the registrations or Measure Extract inspections for each point.
2. Right-click in the inspection tree to see the Inspection menu.
3. From the Inspection menu, select Add > Dimension > Distance. The dimension is added to the inspection tree. Re-name it to something more meaningful to you.

- The Distance menus are displayed and the region is shown on the image. (The menus are described below) Adjust the parameters as necessary.

➤ **To set up a basic Distance measurement:**

- Choose a Distance Component from the Distance tab.
- Go to the Extraction 1 tab and click the **Select Inspection** button.
- Select the first reference point (in the inspection tree) you want to use for the Distance measurement. Click the **Select Inspection** button again to complete the selection.
- Go to the Extraction 2 tab and click the **Select Inspection** button.
- Select the second reference point (in the inspection tree) you want to use for the Distance measurement. Click the **Select Inspection** button again to complete the selection.
- Go back to the Distance tab and set the Distance Limits.
- Adjust other parameters as necessary.

## Distance menu

❖ *Note: The symbol [P] indicates that this value is in pixels. Your system may show [mm] for millimeters, ["] for inches, or [ ] blank for custom units. It indicates that this value can be calibrated using **Review Camera Calibration** (on page 144) or **Image Analysis** (on page 138) for the current sensor.*

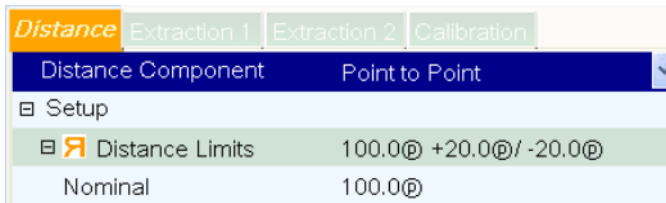

### Distance Component

**Point to Point** -- [most common] Find the distance between two reference points.

**Perpendicular to Orientation** and **Parallel to Orientation** -- These two modes are good for measuring distance across a bottle finish. You would set this mode depending on the part orientation.

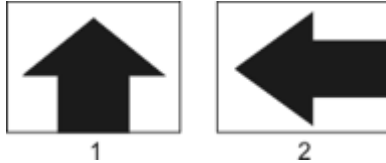

1	Part oriented upright - use Perpendicular to Orientation
2	Part oriented sideways - use Parallel to Orientation

❖ *Note: If you use Finish Location or Centerline registrations for either of the extractions, note that these registrations produce an orientation. The distance measured will reference the orientation produced by the Finish Location or Centerline registrations. If using other inspections, zero degrees or ninety degrees is used as a reference.*

### Setup

Set up the reject criteria for the measurement.

### Distance Limits

Specify the minimum and maximum distance between the two reference points.

### Nominal

The ideal distance.

## Extraction 1 and Extraction 2 menus

❖ Note: when only one inspection is used for Extraction, the second reference point used is the center of the screen.



### Select Extraction

These menus allow you to choose an inspection to use as a reference point for the measurement. Click the **Select Inspection** button, then choose an inspection from the inspection tree. Click the **Select Inspection** button again to set the choice. The Assigned Inspection and Location Provider Type information is filled in -- you cannot manually change these.

In this example, we chose Hough as Extraction 1 and Feature as Extraction 2 from the inspection tree. Those inspections become highlighted when Distance is selected in the inspection tree and/or is being edited.

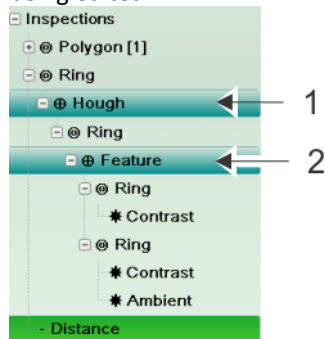

### Reference Point

(Available when you use the Measure Extract inspection) Choose which edges to use when computing Distance.

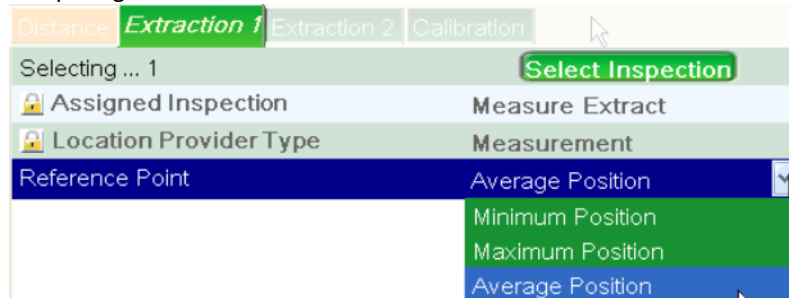

**Minimum Position** -- The system will use the minimum distance of the search region, and reject parts if the measurement is out of limits.

**Maximum Position** -- The system will report the maximum distance of the search region, and reject parts if the measurement is out of limits.

**Average Position** -- The system will report the average distance of the search region, and reject parts if the measurement is out of limits.

Suppose the illustration below indicates a search region, in which the system is searching from right to left, seeking a light to dark transition. Position 1 is the Maximum Position. Position 2 is the Average Position. Position 3 is the Minimum Position found in the search region.

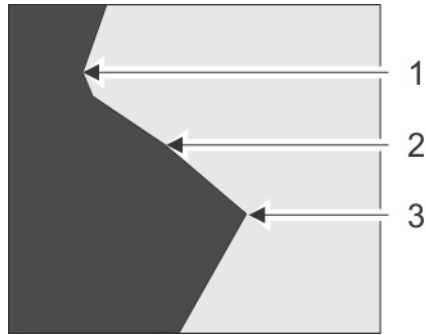

### Finish Corner

(Available when you use Finish Location as the extraction for Distance) Choose which corner to use as a reference when computing Distance.

Distance	Extraction 1	Extraction 2	Calibration
Select Extraction 1	<b>Select Inspection</b>		
Assigned Inspection	Finish Location		
Location Provider Type	Finish Registration		
Finish Corner	Corner 1		

### Calibration menu

Use this menu to program the system to translate pixels into your desired units of measure (mm, for example).

Distance	Extraction 1	Extraction 2	Calibration
Calibration Mode	Inspection Calibration		
Units	Pixels		
Conversion Factor	1.0		
Learn Calibration	<b>Learn Calibration</b>		
Learn Calibration	<b>Save Calibration</b>		
Measured Distance	-1.0		

### Calibration Mode

The system will convert the pixel dimensions into your preferred unit of measurement.

**Sensor Calibration** -- Use the calibration previously set up for the sensor through **Image Analysis** (on page 138) or through another inspection.

**Inspection Calibration** -- Use the calibration from this inspection only.

### Units

Choose your preference in the reporting of the measurements. Choose from millimeters, inches, pixels, and custom. Custom allows any calibration factor to be used.

### Conversion Factor

This indicates the pixel size and is used to convert one pixel into the units selected. The initial conversion will be controlled by the Learn Calibration results. You can adjust this value manually if necessary.

### Learn Calibration

Click the **Learn Calibration** button to automatically determine the scale factor, which converts the value to the desired units.

❖ *Note: you must first enter the Measured Distance before learning calibration.*

### Save Calibration

Click the **Save Calibration** button to save the calibration scale and units to the sensor for use by other inspections.

### Measured Distance

Measure your part with calipers or another tool, then enter the actual value for Measured Distance. This is used to help calibrate the measurement.

## Angle

Angle computes the difference in angles between two orientations or registrations. Angle does NOT use a region by itself. It uses information obtained in previous registrations or orientations. To measure an angle, use at least one registration or orientation - anything that produces an orientation. Examples where Angle could be used are to find skewed labels, or turned tabs on converted ends or EZO ends.

Inspections that produce an orientation, that can be used to compute an angle include:

**Centerline** (on page 225)

**Finish Location** (on page 227)

**Template Registration** (on page 231)

**Pattern Match** (on page 244)

**Template Orientation** (on page 246)

**Label Skew Extract** (on page 282)

In the example below, a label angle is computed with respect to the centerline of the part.

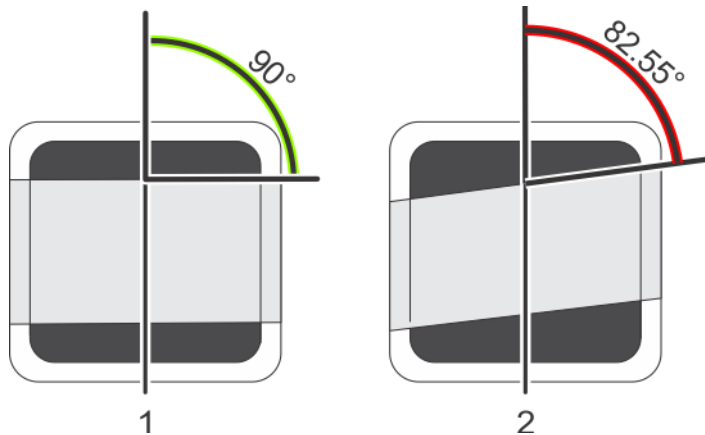

1	Good part
2	Bad part - label angle is out of tolerance

You can measure the angle with respect to zero degrees on the image, if desired.

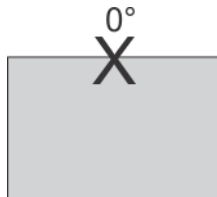

#### ➤ To add an Angle dimension:

1. Make sure at least one inspection that produces an orientation has been added to the inspection tree. [see list above]
2. Right-click on the item you just added.

3. From the Inspection menu, select Add > Dimension > Angle. The Angle dimension is added to the inspection tree. Re-name the inspection to something more meaningful to you.
4. The Angle menu (along with two Orientation menus) is displayed and the region is shown on the image. (The menu is described below) Adjust the placement of the region and parameters as necessary.

➤ **To set up Angle dimension:**

1. Select the Orientation 1 menu.
2. Click the **Select Inspection** button.
3. From the inspection tree on the left side of the screen, choose an inspection to reference one angle. The inspection you choose must be one that produces an orientation. See list at the beginning of this topic.
4. Click the **Select Inspection** button again to complete the selection.
5. If you have another inspection to reference, use the **Select Inspection** button in the Orientation 2 menu. If you do not have another inspection to reference, the system uses zero degrees on the image as a reference.
6. Go to the Angle menu and set the Angle Limits to pass or fail parts based on your quality control criteria. For example, a part may be rejected if the angle of the label is too large compared to the centerline of a bottle.
7. Adjust other parameters as necessary to pass or fail parts per your criteria.

## Angle menu

Angle	Orientation	Orientation
☐ Angle Limits	0.0° +/-245.9°	
Nominal	0.0	
Angle Mode	Largest Angle	
Flip Angle 180	<input type="checkbox"/> Enabled	

### Angle Limits

Set the valid range of measured angles per your specifications.

### Nominal

The ideal angle measured.

### Angle Mode

Use the Smallest or Largest Angle. An example: the system could measure an angle at 2° or 358° depending which direction it is measuring. Choose whether to use the smallest or largest angle found.

### Flip Angle 180

Use this option if your angles are pointing in opposite directions and you want them aligned in the same direction. Sometimes this depends on how a ribbon was drawn, for example.

## Orientation menu (1 or 2)

Pick the reference point(s) to measure the angle.

❖ *Note: when only one inspection is used for Extraction, the reference angle used is zero degrees, so the inspection would measure the angle with respect to zero degrees.*

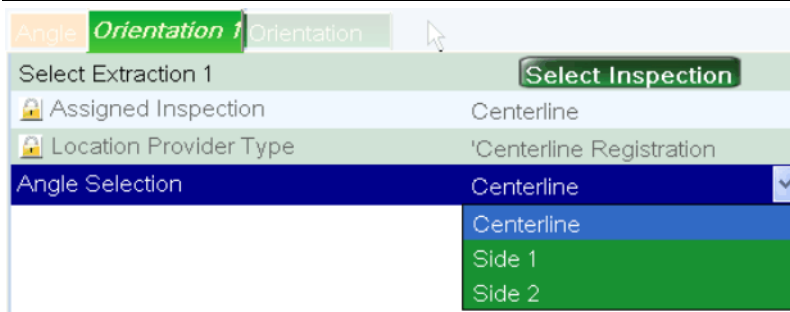

### Select Extraction

These menus allow you to choose an inspection to use as a reference point for the measurement. Click the **Select Inspection** button, then choose an inspection from the inspection tree. Click the **Select Inspection** button again to set the choice. The Assigned Inspection and Location Provider Type information is filled in -- you cannot manually change these.

In this example, we chose Finish Location as Extraction 1 and Centerline as Extraction 2 from the inspection tree. Those inspections become highlighted when Angle is selected in the inspection tree and/or is being edited.



### Angle Selection

This parameter is available when the inspection selected for the extraction contains more than one data point to reference. Examples include Finish Location or Centerline. Select the data point to which you want to reference the angle.

---

## Correlation

There are no correlation inspections in the system.



# Chapter 14

## System Hardware Information

This section shows wiring diagrams and pinouts, and lists signals of various Intellispec system components.

❖ *Note: some sections are only included in books pertaining to specific applications. This book may not contain all of the sections below.*

Related sections include:

- Cluster Box
- **Inspection Module Adjustments** (see "**Inspection Modules**" on page 305)
- **Extended I/O** (on page 337)
- Maintenance Frequency - BNS
- **Maintenance Frequency** (on page 349) - Integrated Tunnels

---

## Power Up

The Intellispec Series V CSL system has one power switch on the back of the enclosure that provides power to all components in the system.

---

## Power Down

To power down the Intellispec Series V CSL and its components, turn off the switch located on the back of the unit.

### **Important**

If you re-start the computer, turn off the User Interface power and leave it off for about 40 seconds before turning it back on. This allows the electronic components to correctly reset.

To see the locations of the power switches, refer to **Power Up** (on page 295).

---

## Servicing the User Interface



### **Warning**

Potential hazardous voltage from the UPS. Use caution when servicing.

# Wiring Diagrams

## Pressco PC outlet wiring



### Warning

The Pressco PC outlet is only to be used to provide power to the Intellispec PC. Any other use is prohibited.

#### AC POWER WIRING

100-240VAC  
50/60HZ  
300W MAX.

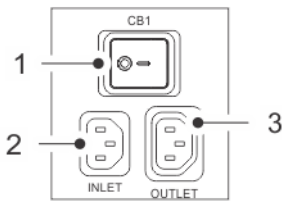

EXTERNAL VIEW  
AC POWER CONNECTORS

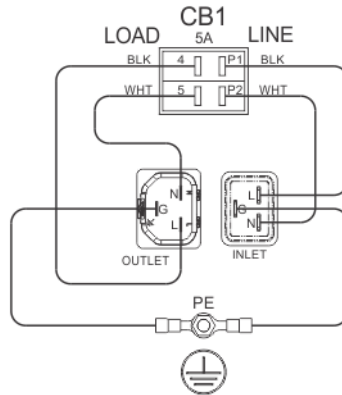

INTERNAL VIEW  
AC POWER CONNECTORS

1	User interface power switch
2	AC Power in
3	UPS AC Power

## User Interface external connections - 120VAC UPS

❖ Note: the connectors not called out in the diagram have no connection.

### INTERCONNECT DIAGRAM 120VAC UPS

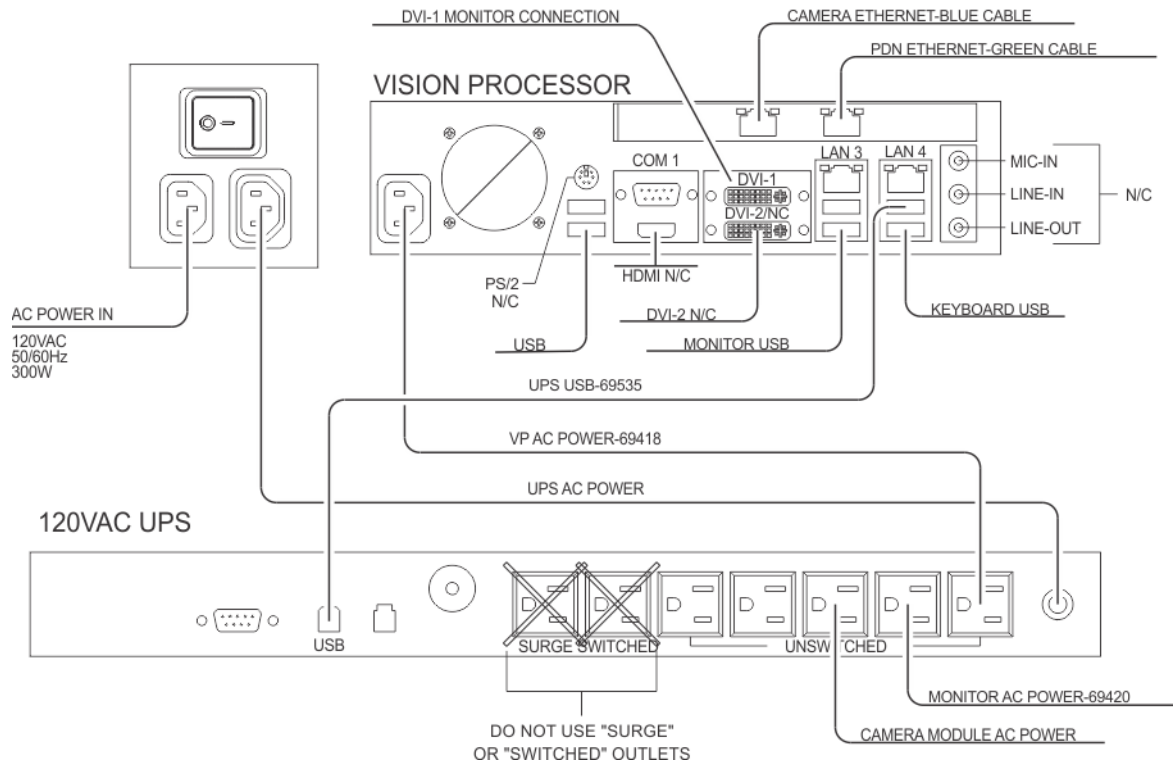

# User Interface external connections - 230VAC UPS

❖ Note: the connectors not called out in the diagram have no connection.

## INTERCONNECT DIAGRAM 230VAC UPS

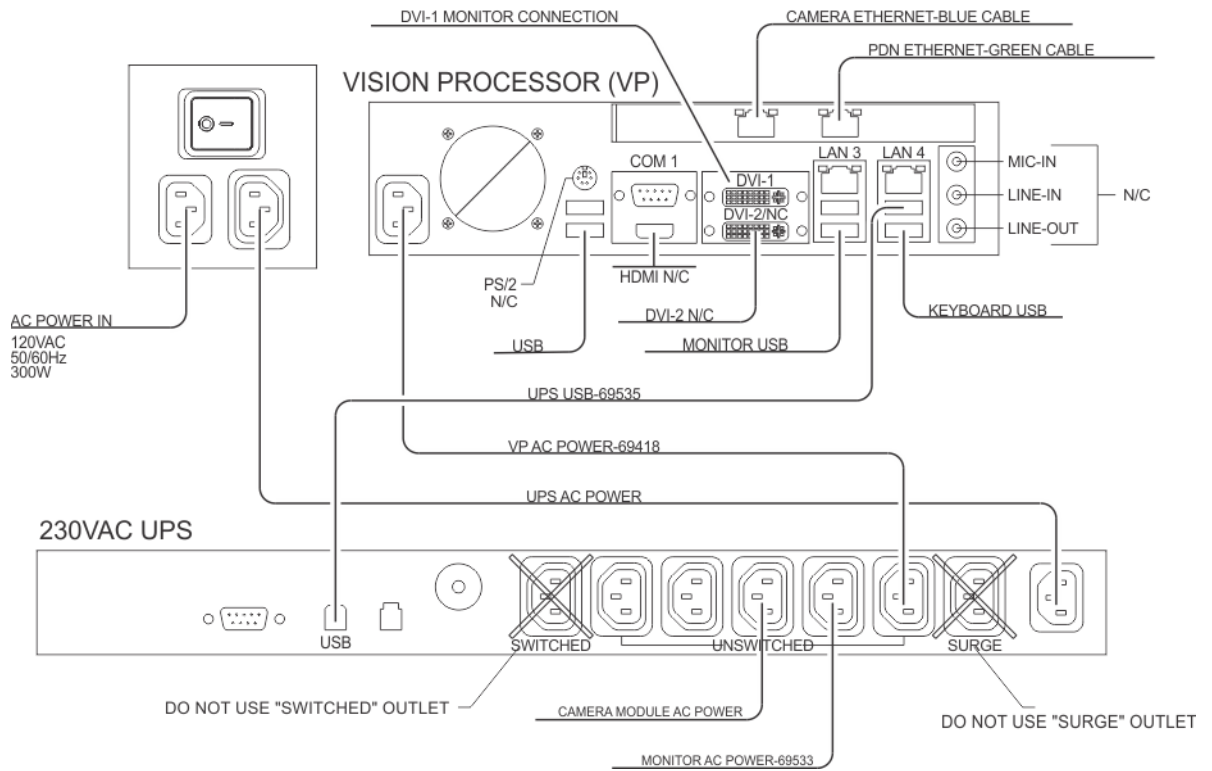

## User Interface internal connections

The following diagram shows the internal USB connections of the Intellispec Series V CSL unit.

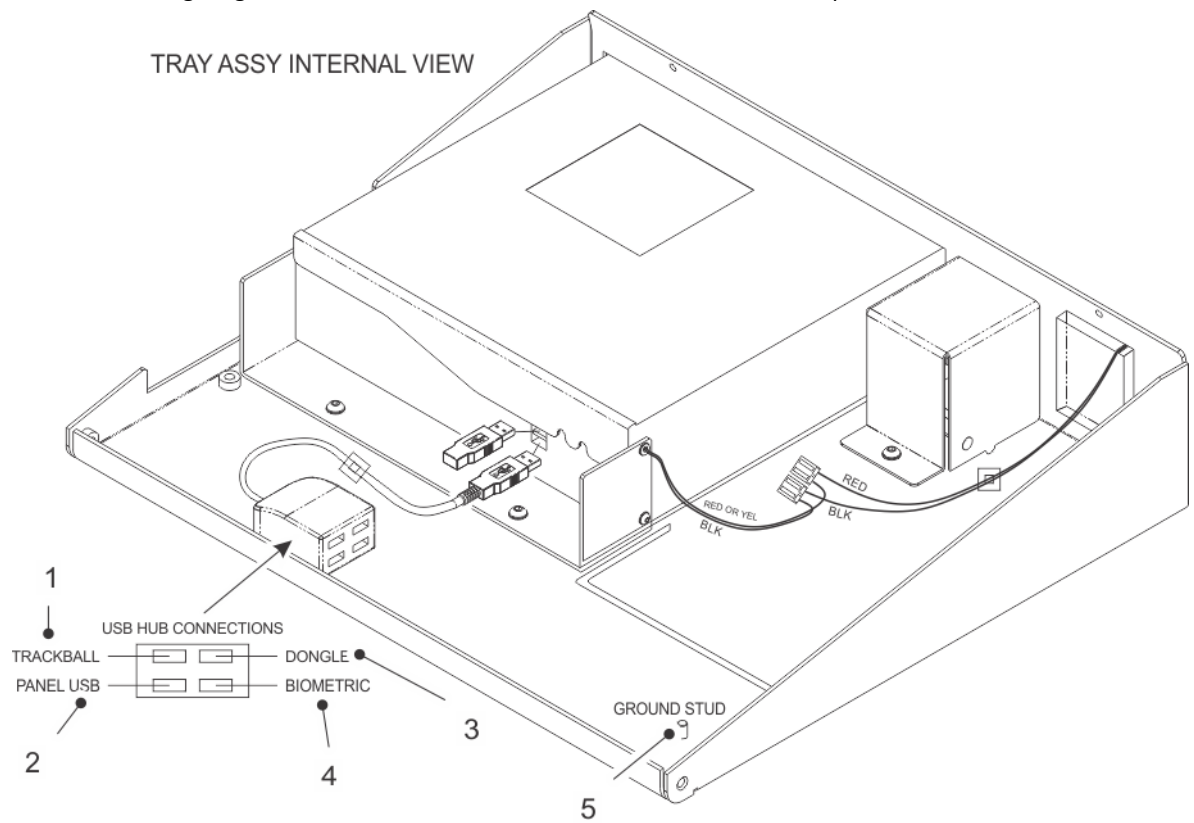



1	Trackball USB connection
2	Panel USB connection
3	Dongle
4	Biometric device USB connection
5	ground stud (for reference)





## ! Important

When restarting the software, it is important to choose the correct option from the Shut Down System menu. Only select Shut Down Intellispec and Restart Computer as described below.

### ➤ To restart the Intellispec software:

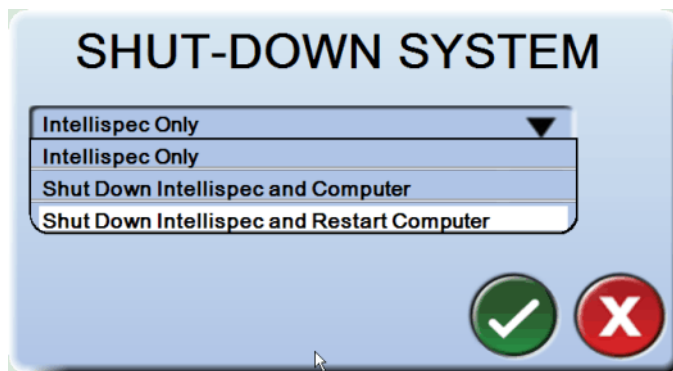
1. Log in.
2. Make sure all lanes are offline (all lanes have the red stoplight). For more information, see **Online / Offline** (on page 44).
3. Click the Home button .
4. Click the Tools button  to display the Tools menu.
5. Click the Exit System option.
6. A drop-down menu allows you to choose an option. Choose: "Shut down the Intellispec and restart the computer."



7. Click the OK  button. The Intellispec software and computer shuts down and restarts. The software will come up in System Overview mode where you can log in to continue operating the system.

## Rebooting the computer

If restarting the application does not clear the errors, or the software does not restart, or you see the "System in Transition" message, try rebooting the computer.

1. Connect the **Mechanical keyboard (MKB)** (on page 35).
2. Press Ctrl + Alt + Delete on the mechanical keyboard.
3. Use the Log Off option to log off of Intellispec.
4. At the Windows Login Prompt, enter "pvpass" as the password for the Intellispec user account. Once login is complete the Series V application software will be launched.

❖ *Note: The system reboot takes several minutes to complete.*

## Vision Processor Shutdown

If restarting the application or computer does not clear the errors, try rebooting the entire system. This involves shutting down the software and removing power.

### ➤ To shut down the Vision Processor:

1. Without exiting from the Intellispec software application, turn off the Vision Processor ON/OFF switch on the back of the User Interface. For the location, see **Power Up** (on page 295).
2. WAIT while the UPS shuts down - approximately 30-40 seconds.
3. Leave the Vision Processor off for an additional 40 seconds to allow the inspection module LPIP to discharge.
4. Turn on the Vision Processor switch to restart the system. The software will come up in System Overview mode where you can log in to continue operating the system.



## Important

The Vision Processor ON/OFF switch must be off for approximately 40 seconds to before turning it back on for proper restart.

## Light Tree

The optional light tree may be mounted on or near an inspection module, or near a cluster box (if applicable). The optional horn, mounted with the light tree provides an audible warning.

For more information, refer to **Light tree status** (on page 302).



Light Tree (optional)

- Red (Alarm)
- Amber (Warning)
- Green (Online)
- Blue (Power)

## Light tree status

The lights on the optional light tree will turn on, off, or blink depending on status of certain hardware. Each lane has its own light tree. The table below lists the different states for each light.

Light color	Condition	What it means
Red	On - steady	Alarm condition
Red	On - blinking	Part tracker board lost communication with the host PC or has an error and needs to initiate an alarm
Red	Off	No alarm ( <b>OK</b> )
Amber	On	Warning alarm condition
Amber	Off	No warning ( <b>OK</b> )
Amber	0.5 second flash	Auto reset of Asynchronous Correlation FIFO (not used in all systems)
Green	On	Lane is online
Green	Off	Lane is offline
Blue	On	Part tracker board has power ( <b>OK</b> )
Blue	Off	Part tracker board has no power





# Chapter 15

## Inspection Modules

This section covers camera adjustments that may be required to keep the inspection modules working properly. Adjustments include the camera position, aperture, and camera focus.

The focus adjustment controls the clarity of the image; the aperture adjustment controls the amount of light admitted by the shutter. Normally the inspection modules do not require further adjustment after initial system setup. Circumstances that might require additional adjustments are camera replacement, strobe replacement, or a substantial change in part size or color.



### Danger

The inspection modules are mounted near moving machinery. Use extreme caution to avoid contact with moving machinery when servicing inspection modules as serious personal injury could result. Ensure machinery is in an emergency stop state before servicing inspection modules.

## Observe Part Image

When adjusting the focus, aperture, or height for any inspection module, it is helpful to use **Offline Imaging** (on page 137) so that you can immediately see the effect of an adjustment on the image quality. Use the Run feature in Immediate Mode.



➤ **To use Run in Immediate Mode:**

1. Make sure the lane is offline.



2. Click the desired Sensor button to view Sensor Overview mode.

3. Right-click the Sensor button to see the Sensor menu.
4. Select **Offline Imaging** from the menu.
5. Click the **Run** button under Immediate Mode. The camera will snap pictures continuously without the need for a part present signal.

While the system is in this mode, you will be able to make adjustments to focus, aperture, or camera height.

---

## Extended I/O in inspection modules

The *Extended I/O* (see "*Extended I/O board*" on page 337) kit (optional) is installed within Chromapulse inspection modules as shown below.

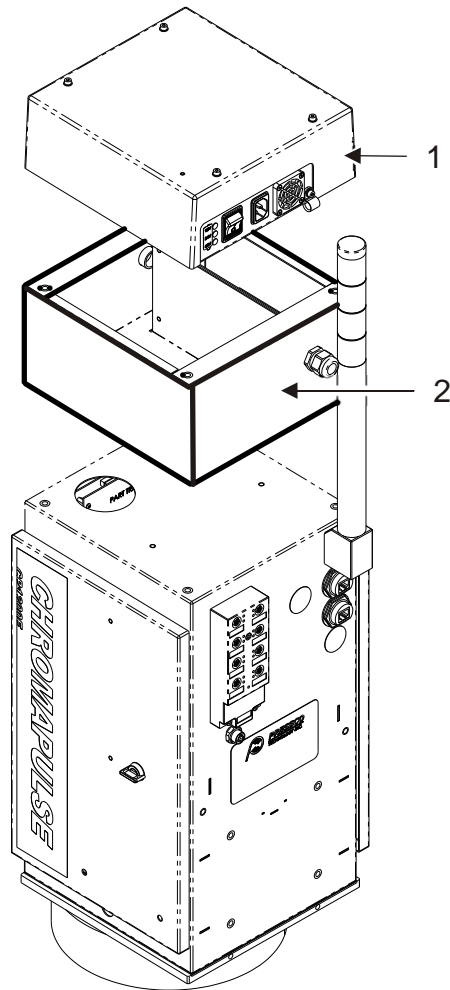

1	power cap
2	Extended I/O kit

## CP/E Series modules

The CP/E series of inspection modules is a group of modules with similar components. The module's appearance and adjustments are similar between models. The difference between model numbers lies in the specific lighting and optics for inspection of different types of parts. To see your model number, look at the label on the outside of the module.

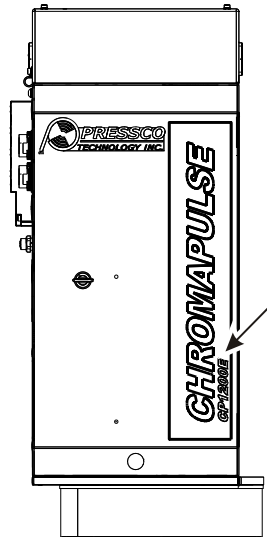

An **Extended I/O** (on page 337) kit is available for the CP/E series inspection modules.

This section covers CP/E models including:

- CP500E
- CP750E
- CP1200E
- CP1500E

The basic components of the CP/EV module are shown below.

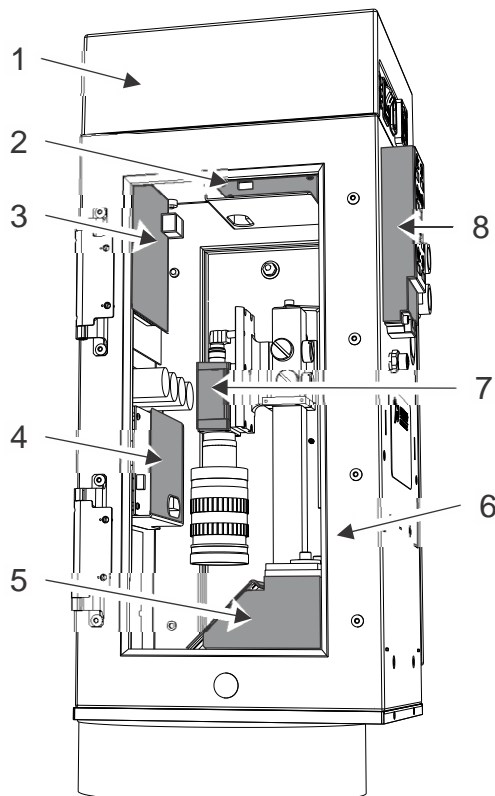

1	Power assembly
2	Second driver and light control module (models CP1200E and CP1500E only)
3	Part Tracker assembly
4	Driver and light control module
5	Fill light module with beam splitter
6	Ethernet switch (mounted on inside wall - not shown)
7	Camera
8	8-port I/O box: <b>CP/ EV inspection module I/O connectors</b> (see " <b>Chromapulse module external connections</b> " on page 315)

## Adjusting the CP/ E Series modules

### Module Height Adjustment

The height of the module is easily adjusted. Refer to the illustration below. Loosen the adjustment knob [item 4] and use the handle [item 3] to move the module up or down. You can move the module with one hand while viewing the image on the monitor. Tighten the knob when desired height is achieved.



#### Caution

Loosen only one knob [2 or 4] at a time. Otherwise, the weight of the module may not be supported.

### Adjust for different part size

- Move the module up or down to increase or decrease the size of the part image – **Observe Part Image - SV** (see "**Observe Part Image**" on page 305) while adjusting module.
- Use camera position adjustment to adjust for small change in part size - **Camera Position Adjustment** (on page 310)
- The adjustable stops [items 1 and 5] can be used to mark where the module is supposed to rest. For example, the bottom stop [item 5] can be placed at the module's lowest inspection height. You can easily raise the module to clean or clear jams, then lower the module back down to the stop.
- The top stop [item 1] can be used to mark the module's highest inspection height – for your largest inspected part.

#### ➤ To adjust module height (or to raise the module for cleaning or clearing jams):

1. Loosen the adjustment knob [item 4].

❖ *Note: if you need a greater range of movement [example: you are changing from inspecting a shorter part to a much taller part], then loosen knob 2 first. Move the module using the handle, then tighten knob 2. Then use knob 4 for smaller adjustments.*

2. Use handle [item 3] to move the module up or down.

3. Tighten the knob [item 4].

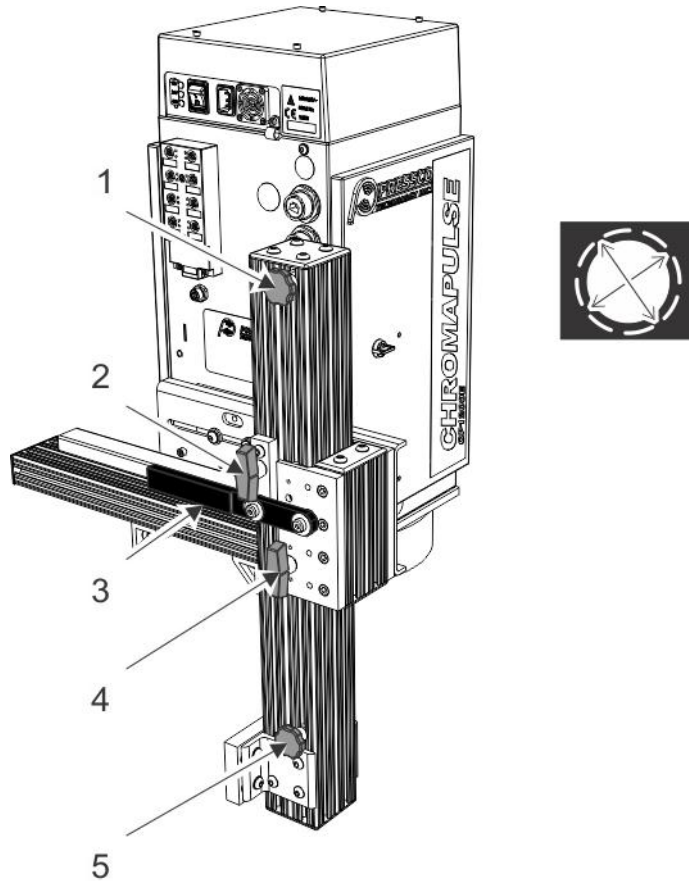

1	Adjustable stop - highest inspection position
2	Range Knob - locks the pivot position in place. Loosen only if you need to increase the range of movement of the module, move the module using the handle, then tighten the knob.
3	Handle - use to move the module up or down
4	Adjustment Knob - loosen to move the module, then tighten to secure the module in place
5	Adjustable stop - lowest inspection position

### **Switch sides**

The CP/E series modules are designed for maximum flexibility to fit into your production line. During installation, the module can be changed so that the height adjustment brackets can be placed on the other side of the module.

Likewise, the doors of the module may be removed and their hinges attached to the other side, for the door to swing oppositely.

### **Camera Adjustments**

If your inspection module has the optional motorized focus and aperture feature, you can adjust the focus and aperture through the software: **Camera Focus and Aperture** (on page 136).

## Focus Adjustment

Look at the part image to observe the adjustments: **Observe Part Image - SV** (see "**Observe Part Image**" on page 305)

To adjust focus, carefully remove or open the inspection module cover. Turn the focus adjust ring while observing the part image on the monitor. Adjust the focus for the sharpest image. If needed, adjust the aperture, then reinstall the cover.

## Aperture Adjustment

The aperture controls the amount of light that passes through the lens. The programmable light source provides the range of light intensity required for most applications. However, you can manually adjust the aperture if necessary by turning the aperture adjust ring on the camera lens. Reinstall the cover.

## Camera Position Adjustment

❖ *Note: Normally, you do not need to adjust camera position. Adjust only if you are initially installing, or have replaced the inspection module.*

The cameras can be adjusted for image size and position. Carefully remove the side panel cover of the inspection module. Adjust cameras as necessary while observing image on Intellispec monitor. After making all camera adjustments, replace module cover.

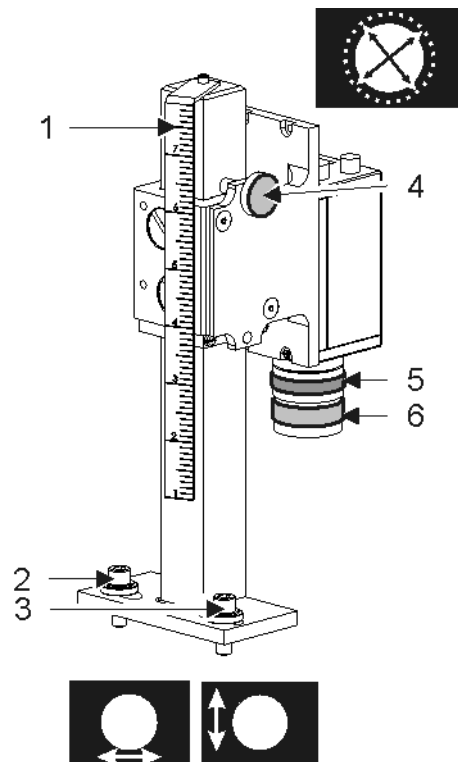

1	Note camera position on scale when adjusting for your part
2, 3	Additional camera position adjustments - horizontal or vertical on Intellispec image
4	Camera position - adjust for image size
5	Focus adjustment (or aperture adjustment depending on lens)
6	Aperture adjustment (or focus adjustment depending on lens)

## Replacing Camera

On rare occasion, you may need to replace a camera in a CP/E inspection module.

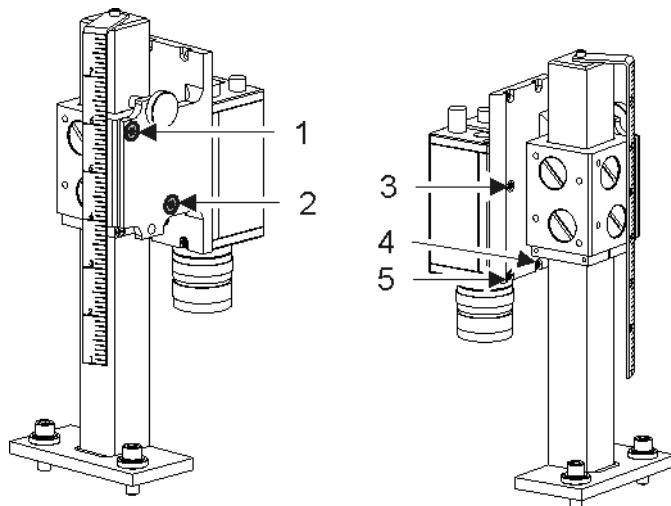

### ➤ To replace camera:

1. Remove the two screws [items 1 and 2].
2. Remove camera from mounting plate and attach new camera.
3. Tighten two screws [items 1 and 2].
4. If necessary, adjust the screws attached to camera bracket [items 3, 4, 5] to square the image on screen.

## Lighting Adjustments

To adjust the lighting, use the software adjustments.

To see the image on the screen:

**Observe Part Image** (on page 305)

Adjust lighting through either:

- **Basic adjust lighting** (on page 141), or
- **Advanced adjust lighting** (on page 142)

Most often, you will use Basic Adjust Lighting.

## Lighting zones CP500E/ CP750E

These modules use one camera and several lighting zones (see below). The camera and lighting zone configuration for CP500E and CP750E are the same; however, the angle of the lighting array of the CP500E is different than that of the CP750E. The illustration below shows the zone grouping for these modules.

These zones are programmed at Pressco and should not be changed. You may view the setup in **Advanced adjust lighting** (on page 142).

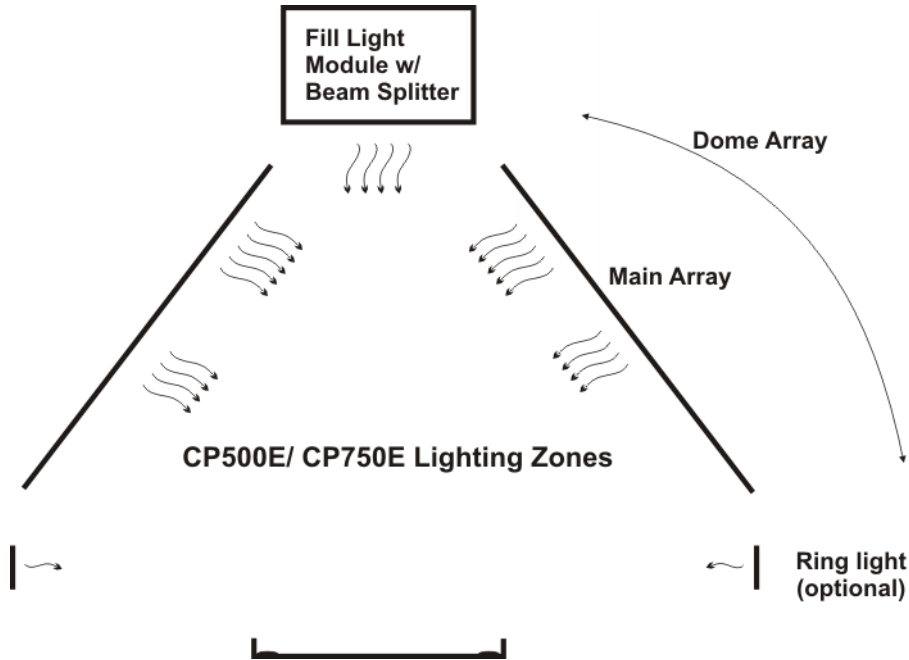

CP500E/ CP750E lighting zones		
Fill light with beam splitter (optional)	Main array	Ring light (optional)
4 zones: <ul style="list-style-type: none"> <li>▪ 1 red zone</li> <li>▪ 1 green zone</li> <li>▪ 1 blue zone</li> <li>▪ 1 IR zone</li> </ul>	9 zones: <ul style="list-style-type: none"> <li>▪ 3 red zones</li> <li>▪ 2 green zones</li> <li>▪ 2 blue zones</li> <li>▪ 2 IR zones</li> </ul>	1 zone: <ul style="list-style-type: none"> <li>▪ 1 red zone</li> </ul>

### **CP1200E/ CP1500E**

These modules use one camera and several lighting zones (see below). The zone configuration is similar between these modules, except that the CP1500E has an additional Lower Light array. The illustration below summarizes the grouping of the light zones for the CP1200E and CP1500E inspection modules.

These zones are programmed at Pressco and should not be changed. You may view the setup in *Advanced adjust lighting* (on page 142).

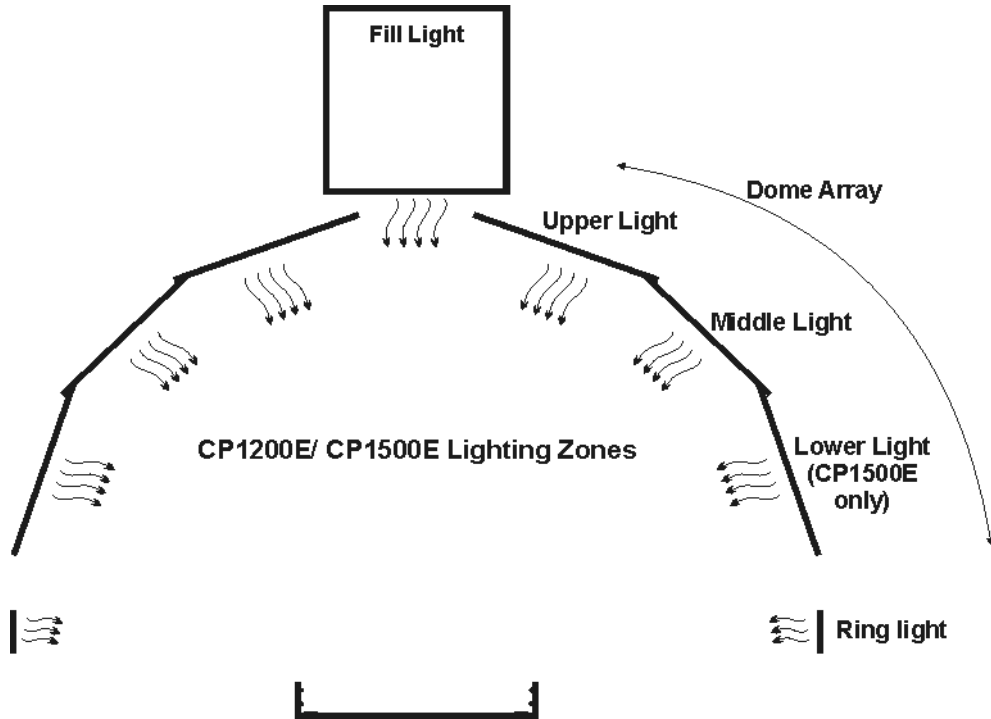

CP1200E lighting zones				
Fill light (optional)	Upper light	Middle light	Ring light (optional)	
4 zones: <ul style="list-style-type: none"> <li>▪ 1 red zone</li> <li>▪ 1 green zone</li> <li>▪ 1 blue zone</li> <li>▪ 1 IR zone</li> </ul>	9 zones: <ul style="list-style-type: none"> <li>▪ 3 red zones</li> <li>▪ 2 green zones</li> <li>▪ 2 blue zones</li> <li>▪ 2 IR zones</li> </ul>	8 zones: <ul style="list-style-type: none"> <li>▪ 2 red zones</li> <li>▪ 2 green zones</li> <li>▪ 2 blue zones</li> <li>▪ 2 IR zones</li> </ul>	4 zones: <ul style="list-style-type: none"> <li>▪ 1 red zone</li> <li>▪ 1 green zone</li> <li>▪ 1 blue zone</li> <li>▪ 1 IR zone</li> </ul>	OR: <ul style="list-style-type: none"> <li>▪ 2 red zones</li> <li>▪ 2 blue zones</li> </ul> OR: <ul style="list-style-type: none"> <li>▪ 4 red zones</li> </ul> OR: <ul style="list-style-type: none"> <li>▪ 1 red zone</li> </ul>

CP1500E					
Fill light (optional)	Upper light	Middle light	Lower light	Ring light (optional)	
4 zones: <ul style="list-style-type: none"> <li>▪ 1 red zone</li> <li>▪ 1 green zone</li> <li>▪ 1 blue zone</li> <li>▪ 1 IR zone</li> </ul>	9 zones: <ul style="list-style-type: none"> <li>▪ 3 red zones</li> <li>▪ 2 green zones</li> <li>▪ 2 blue zones</li> <li>▪ 2 IR zones</li> </ul>	8 zones: <ul style="list-style-type: none"> <li>▪ 2 red zones</li> <li>▪ 2 green zones</li> <li>▪ 2 blue zones</li> <li>▪ 2 IR zones</li> </ul>	8 zones: <ul style="list-style-type: none"> <li>▪ 2 red zones</li> <li>▪ 2 green zones</li> <li>▪ 2 blue zones</li> <li>▪ 2 IR zones</li> </ul>	4 zones: <ul style="list-style-type: none"> <li>▪ 1 red zone</li> <li>▪ 1 green zone</li> <li>▪ 1 blue zone</li> <li>▪ 1 IR zone</li> </ul>	OR: <ul style="list-style-type: none"> <li>▪ 2 red zones</li> <li>▪ 2 blue zones</li> </ul> OR: <ul style="list-style-type: none"> <li>▪ 4 red zones</li> </ul> OR: <ul style="list-style-type: none"> <li>▪ 1 red zone</li> </ul>

# Chromapulse module external connections

❖ Note: this inspection module is not used in all systems. The configuration of your inspection module may vary.

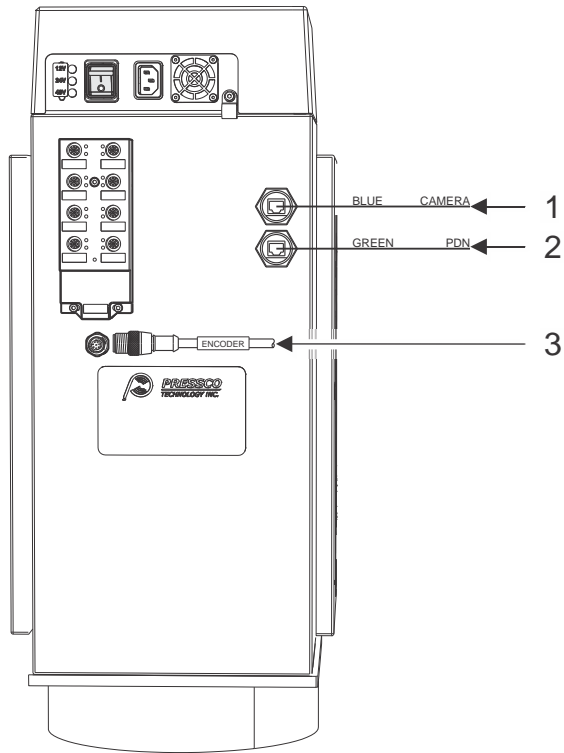

8-PORT I/O BOX-MB1

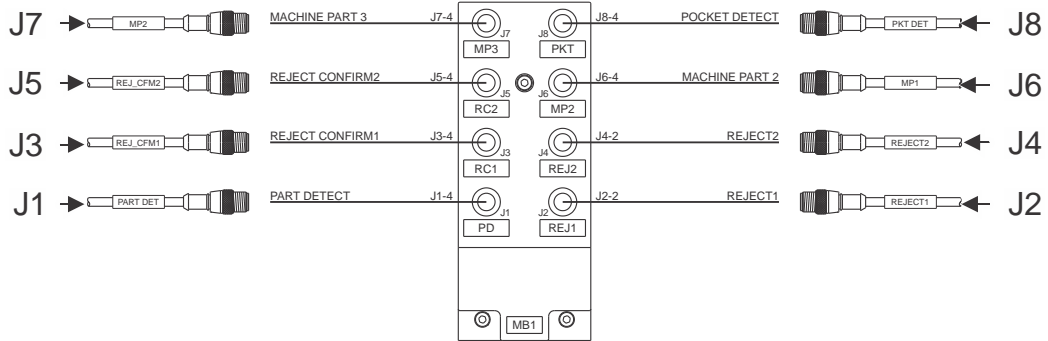

8 port I/O Box MB1		
1		Blue cable - Camera
2		Green cable - PDN (Pressco Device Network)
3		Encoder. 8 pin panel connector.
J1	PD	Part detect
J2	REJ1	Reject 1
J3	RC1	Reject Confirm 1
J4	REJ2	Reject 2
J5	RC2	Reject Confirm 2

8 port I/O Box MB1		
J6	MP2	Machine Part 2
J7	MP3	Machine Part 3
J8	PKT	Pocket Detect

## CP/E inspection module internal connections

This drawing shows the internal wiring typical of inspection modules CP500, CP750, CP1200, and CP1500.

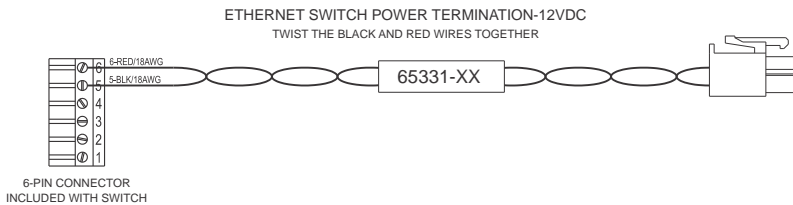
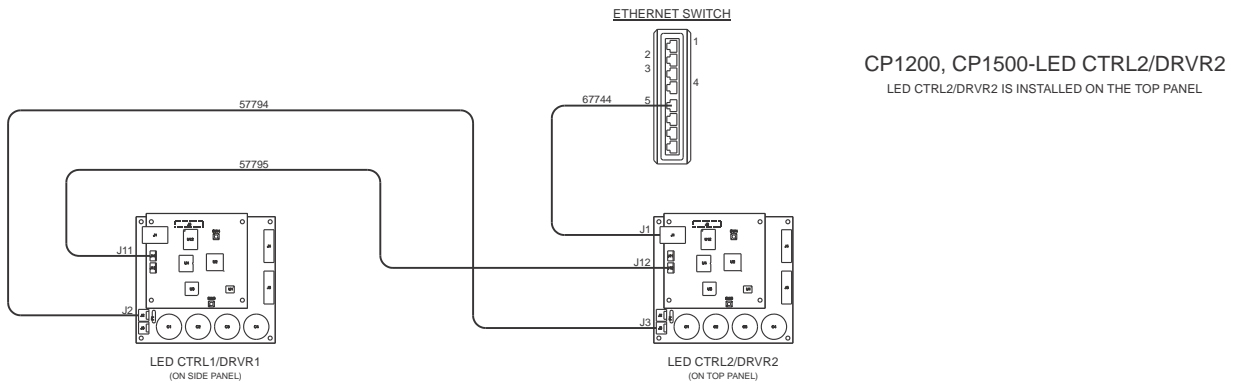
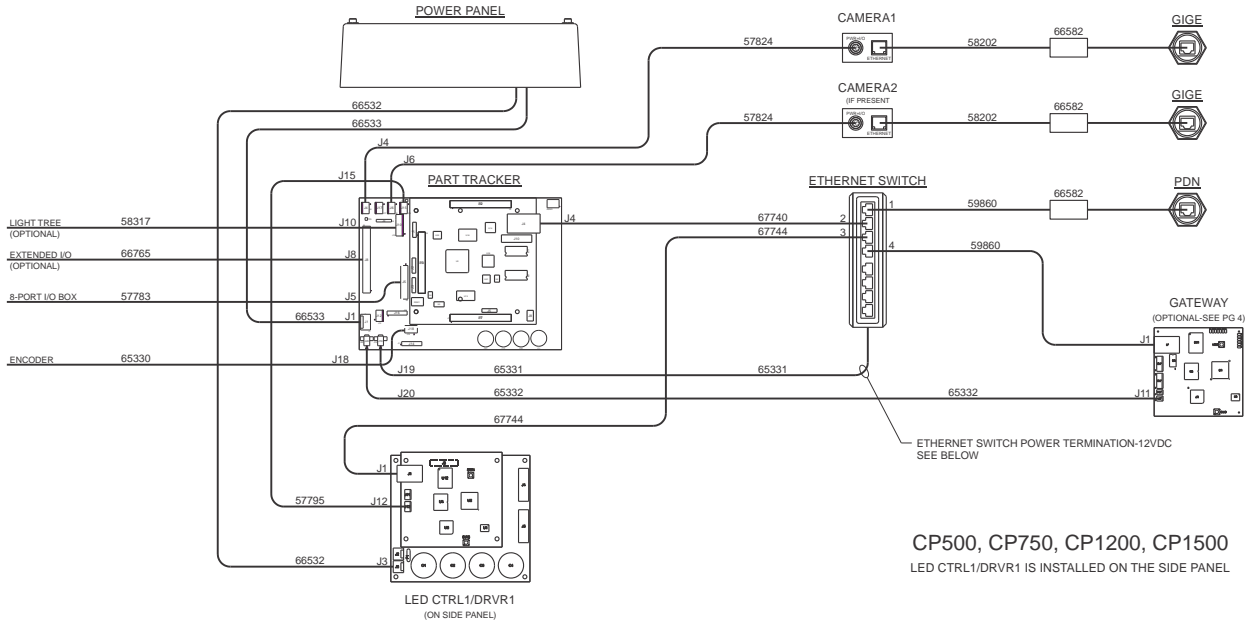

❖ Note: on Part Tracker assembly, switch RSW1 must be set to '0' for proper operation

## CP500E light array connections

### CP500-LIGHT ARRAY CONNECTIONS

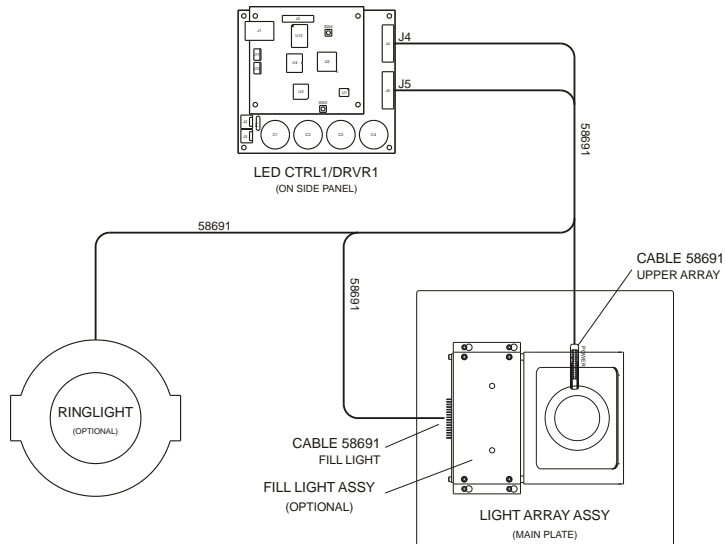

## CP750E light array connections

### CP750-LIGHT ARRAY CONNECTIONS

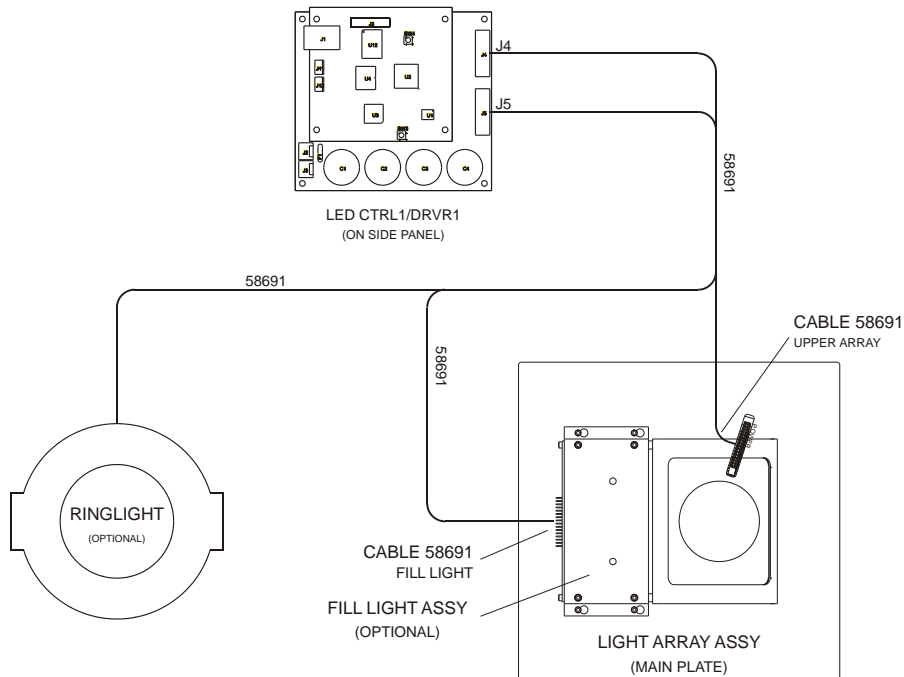

## CP1200E light array connections

### CP1200-LIGHT ARRAY CONNECTIONS

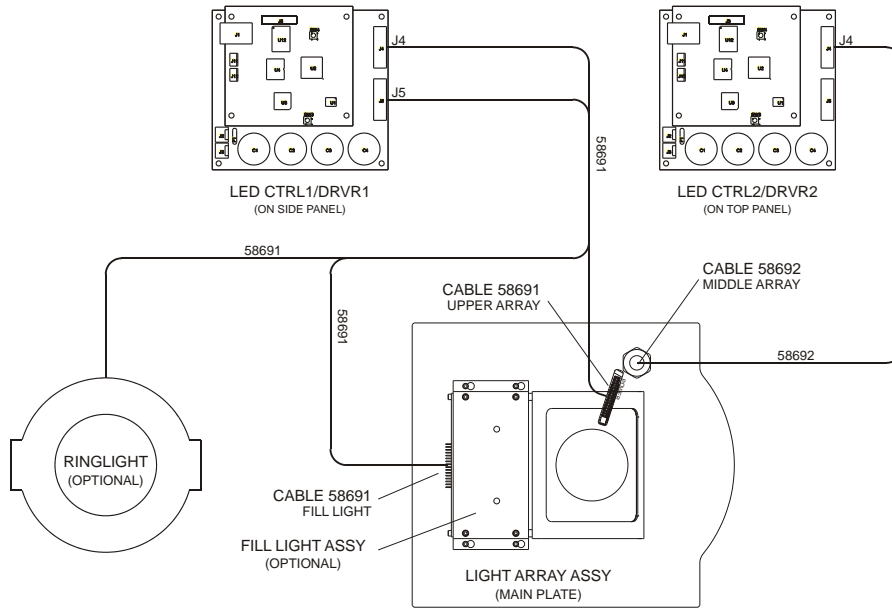

## CP1500E light array connections

### CP1500-LIGHT ARRAY CONNECTIONS

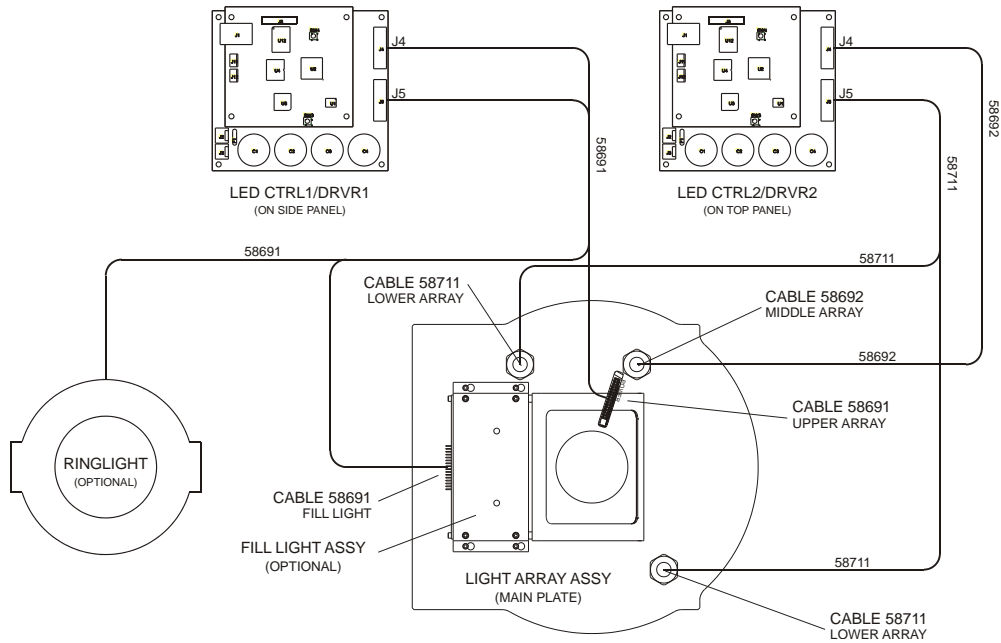

# CP/E Power Panel connections

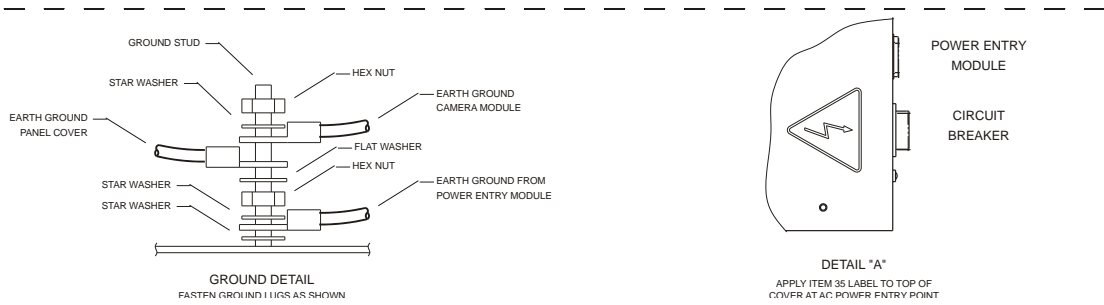
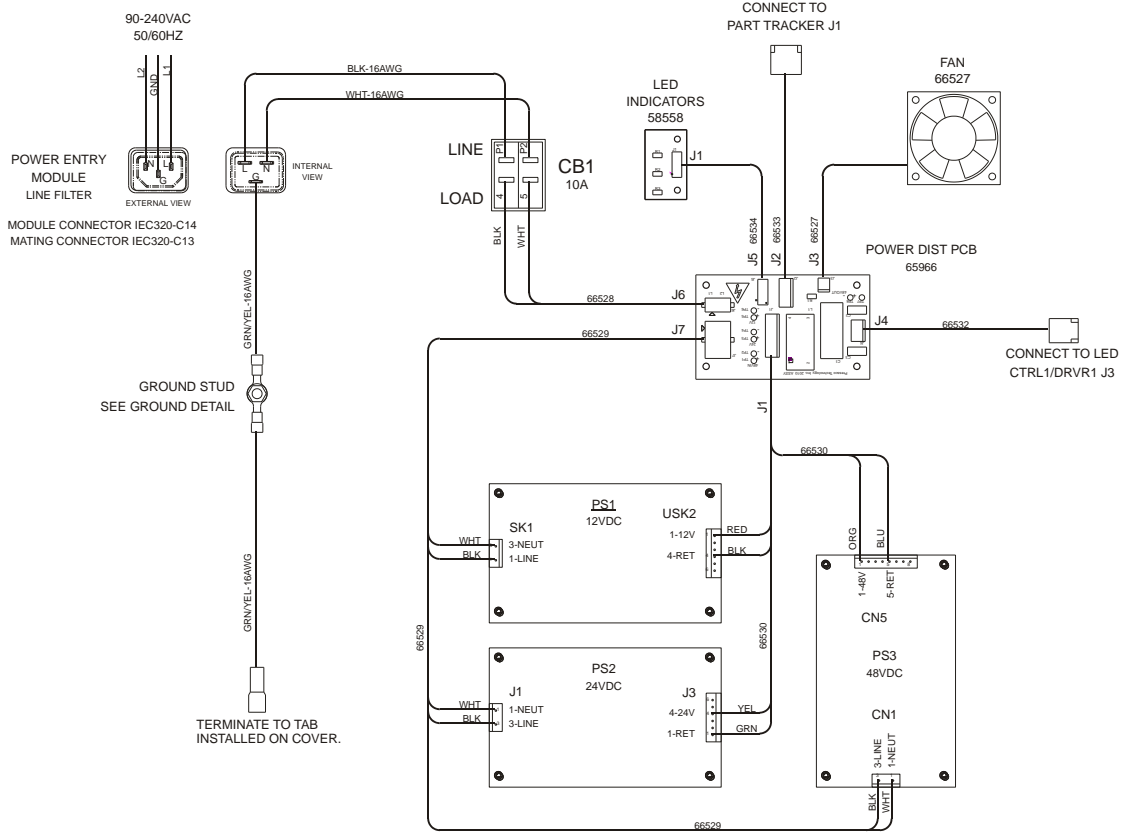

## CP/ E Motorized focus connections (optional)

The following wiring diagram shows the wiring between the motors and controllers for inspection modules that have the motorized focus option.

### MOTORIZED FOCUS CONNECTIONS (OPTIONAL)

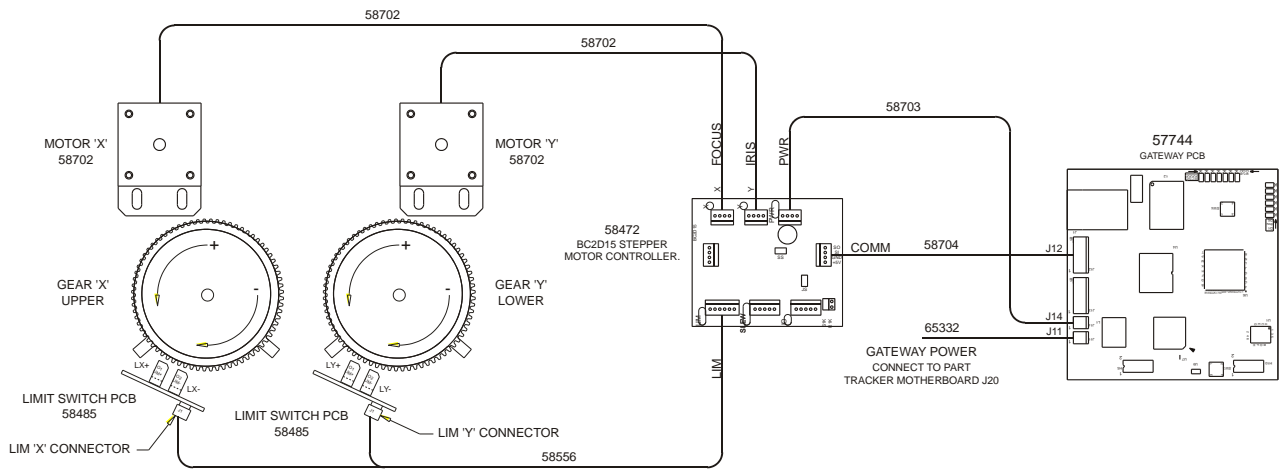

### CAMERA ASSEMBLY

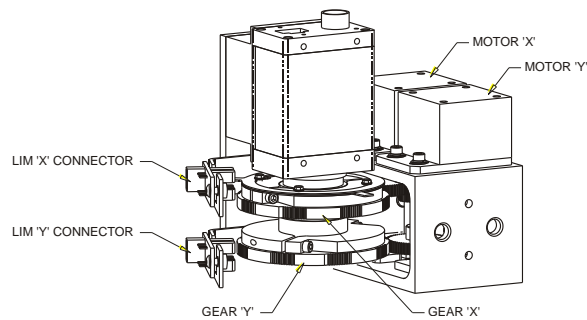

# CP4422EV inspection module

The CP4422E inspection module provides comprehensive inside of can inspection. The module can be configured with up to four cameras to inspect the flange, neck, and body of the can. The main components of the CP4422E are shown below. Note that your system may not contain all components shown.

❖ *Note: if this module is used with an Intellispec Series V CSL system, there is a limit of two cameras.*

The color of the arrays and filters on the cameras dictates what color the camera sees. The Neck camera sees only red light. The Body camera sees only blue light. The Flange camera sees only green light.

An **Extended I/O** (on page 337) kit is available for the CP4422E.

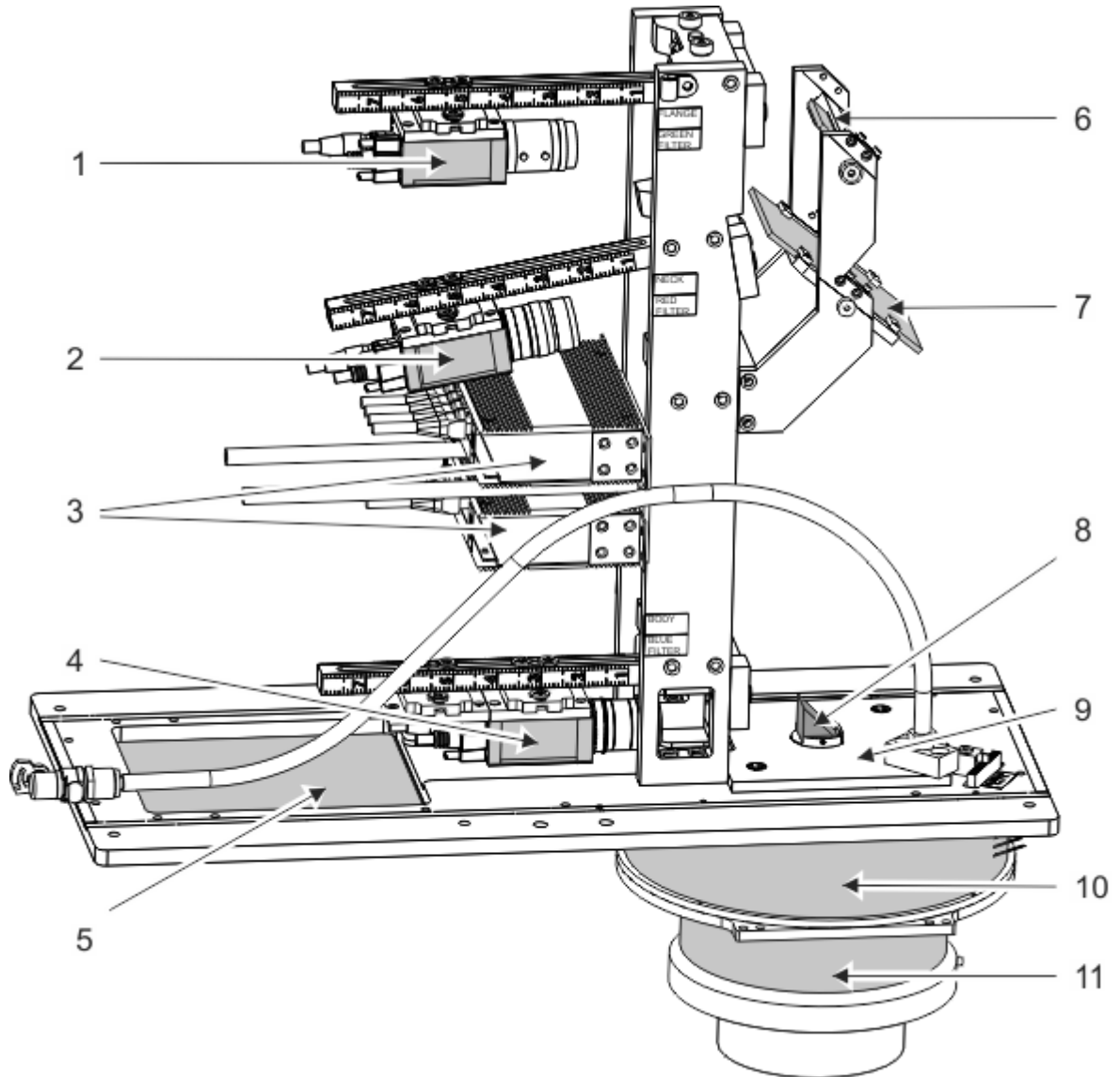

1	Flange camera with Green Pass filter installed
2	Neck camera with Red Pass filter installed
3	Ethernet switch
4	Body camera with Blue Pass filter installed

5	Plate or space for Auxiliary module
6	Beam splitter/ mirror assembly
7	First surface mirror
8	Periscope assembly for body camera
9	Window - neck and flange cameras look through
10	Body, flange, and neck arrays inside
11	Ellipsoidal mirror inside

An auxiliary module may be installed to provide additional inspection (the area inspection depends on your application). It is installed in place of the plate [item 5]. An example auxiliary module is shown below.

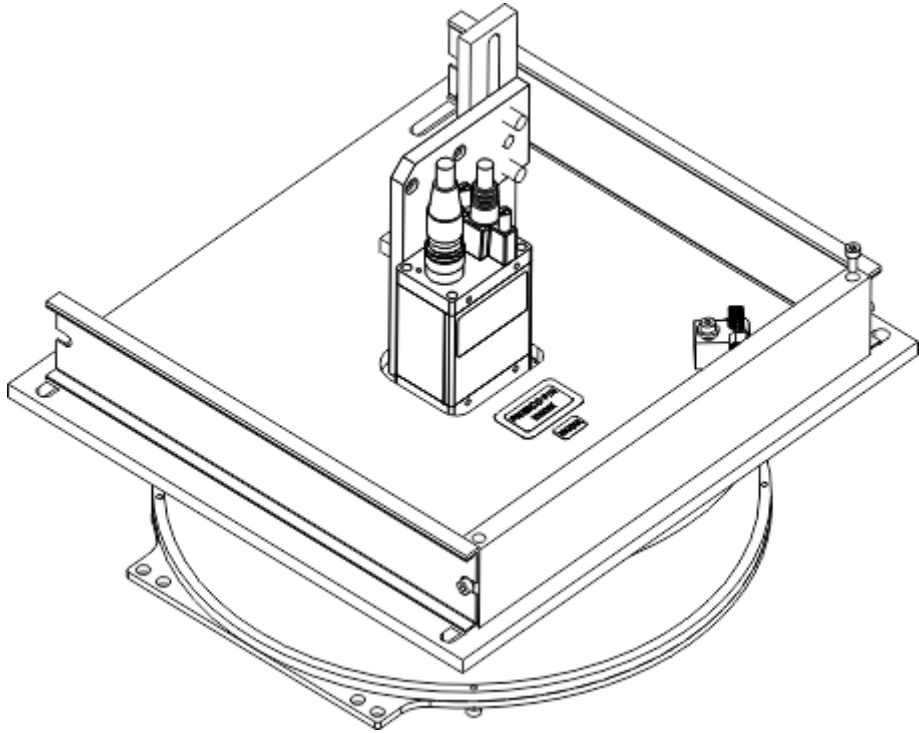

## Adjusting the CP4422EV module

### **Camera Adjustments**

If your inspection module has the optional motorized focus and aperture feature, you can adjust the focus and aperture through the software: **Camera Focus and Aperture** (on page 136).

### **Focus Adjustment**

Look at the part image to observe the adjustments: **Observe Part Image - SV** (see "**Observe Part Image**" on page 305)

To adjust focus, carefully remove or open the inspection module cover. Turn the focus adjust ring while observing the part image on the monitor. Adjust the focus for the sharpest image. If needed, adjust the aperture, then reinstall the cover.

### **Lighting Adjustments**

To adjust the lighting, use the software adjustments.

To see the image on the screen:

**Observe Part Image** (on page 305)

Adjust lighting through either:

- **Basic adjust lighting** (on page 141), or
- **Advanced adjust lighting** (on page 142)

Most often, you will use Basic Adjust Lighting.

### Lighting Zones CP4422E

The illustrations and table below show the lighting zone grouping for the CP4422E inspection module. The illustration shows a module with three cameras installed.

❖ *Note: These zones are programmed at Pressco and should not be changed. You may view the setup in **Advanced adjust lighting** (on page 142).*

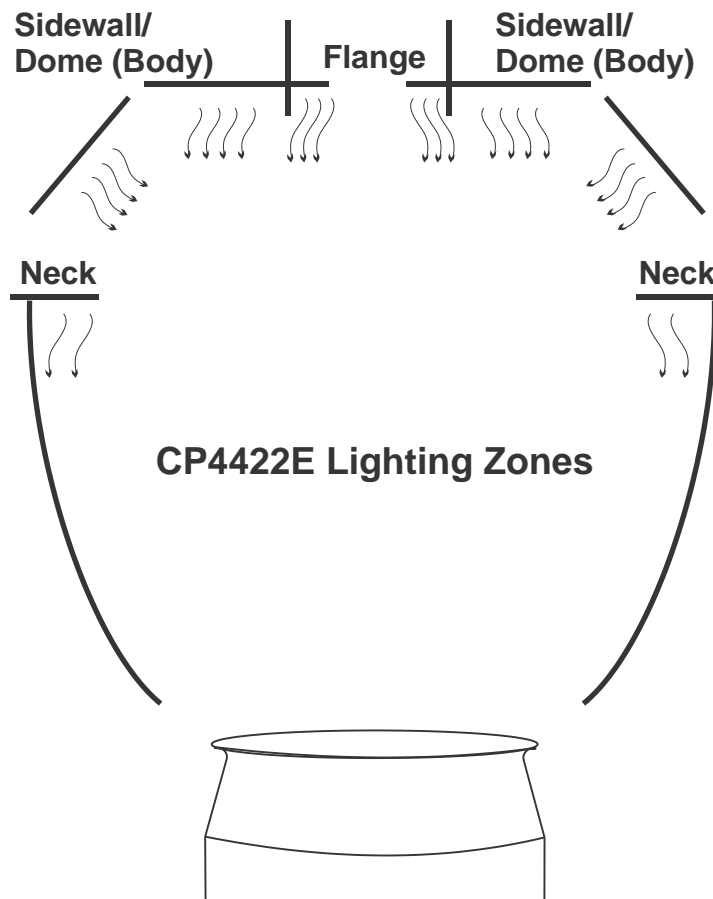

Body (upper array type)	Neck (lower array type)	Flange (ring array type)
10 blue zones	1 red zone	3 green zones

### CP4422E module external connections

❖ *Note: this inspection module is not used in all systems. The configuration of your inspection module may vary.*

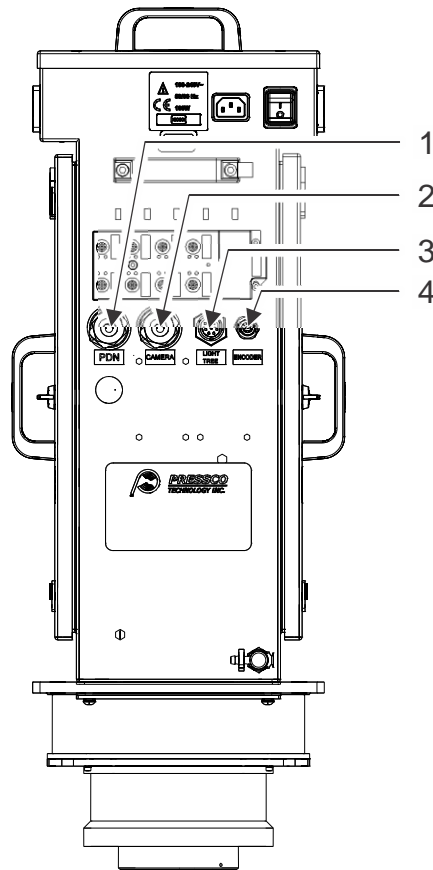

8-PORT I/O BOX-MB1

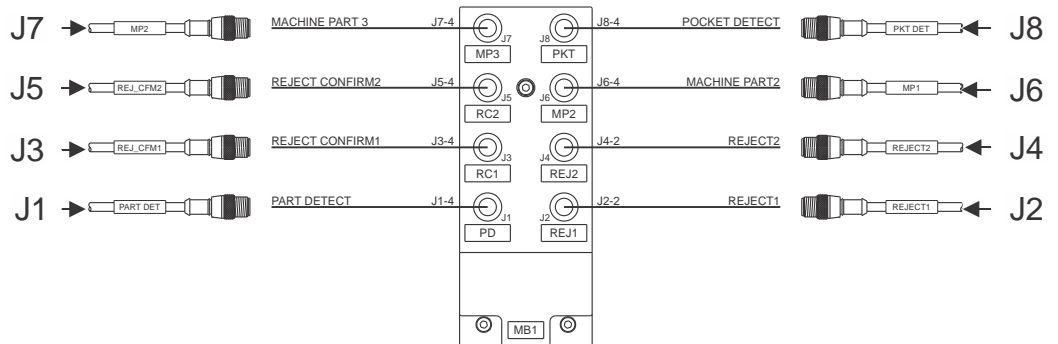

8 port I/O Box MB1		
1		Green cable - PDN (Pressco Device Network)
2		Blue cable - Camera
3		Light tree cable
4		Encoder. 8 pin panel connector.
J1	PD	Part detect
J2	REJ1	Reject 1
J3	RC1	Reject Confirm 1

8 port I/O Box MB1		
J4	REJ2	Reject 2
J5	RC2	Reject Confirm 2
J6	MP2	Machine Part 2
J7	MP3	Machine Part 3
J8	PKT	Pocket Detect

## CP4422EV internal connections page 1

F1291W page 1 of 3

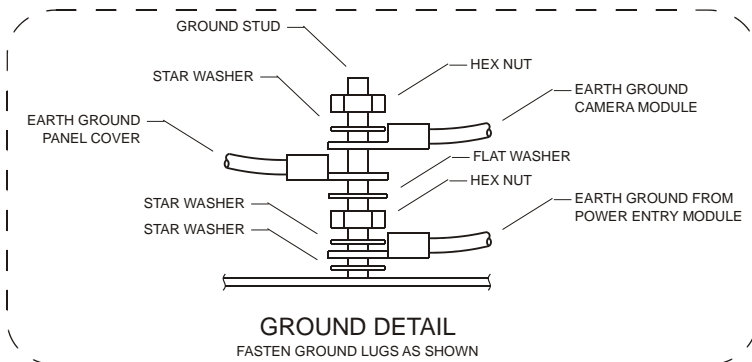
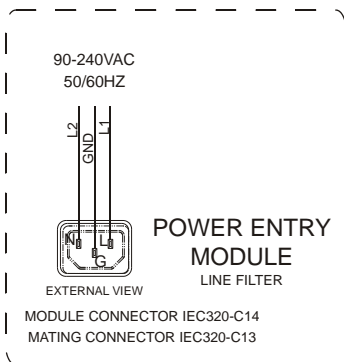
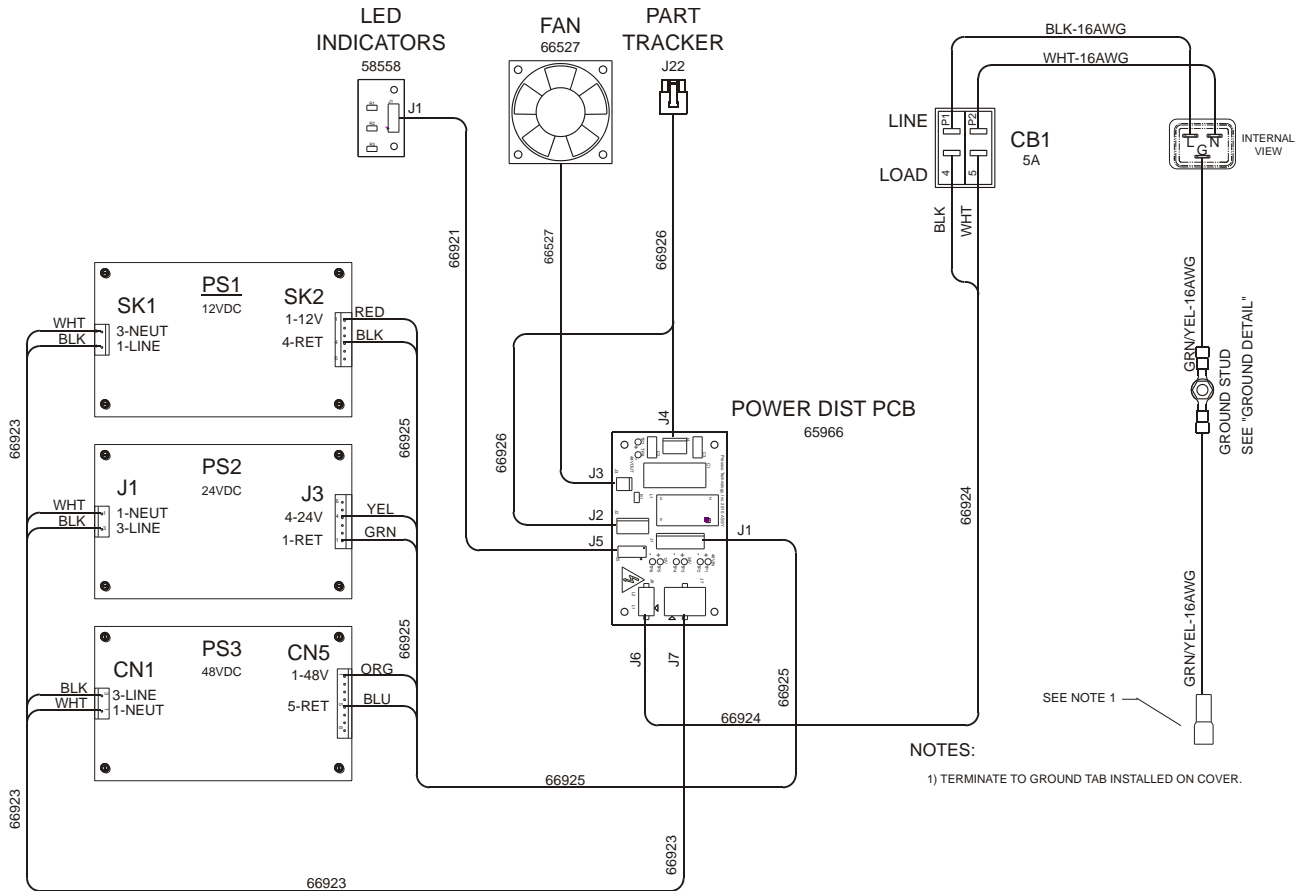

## CP4422EV internal connections page 2

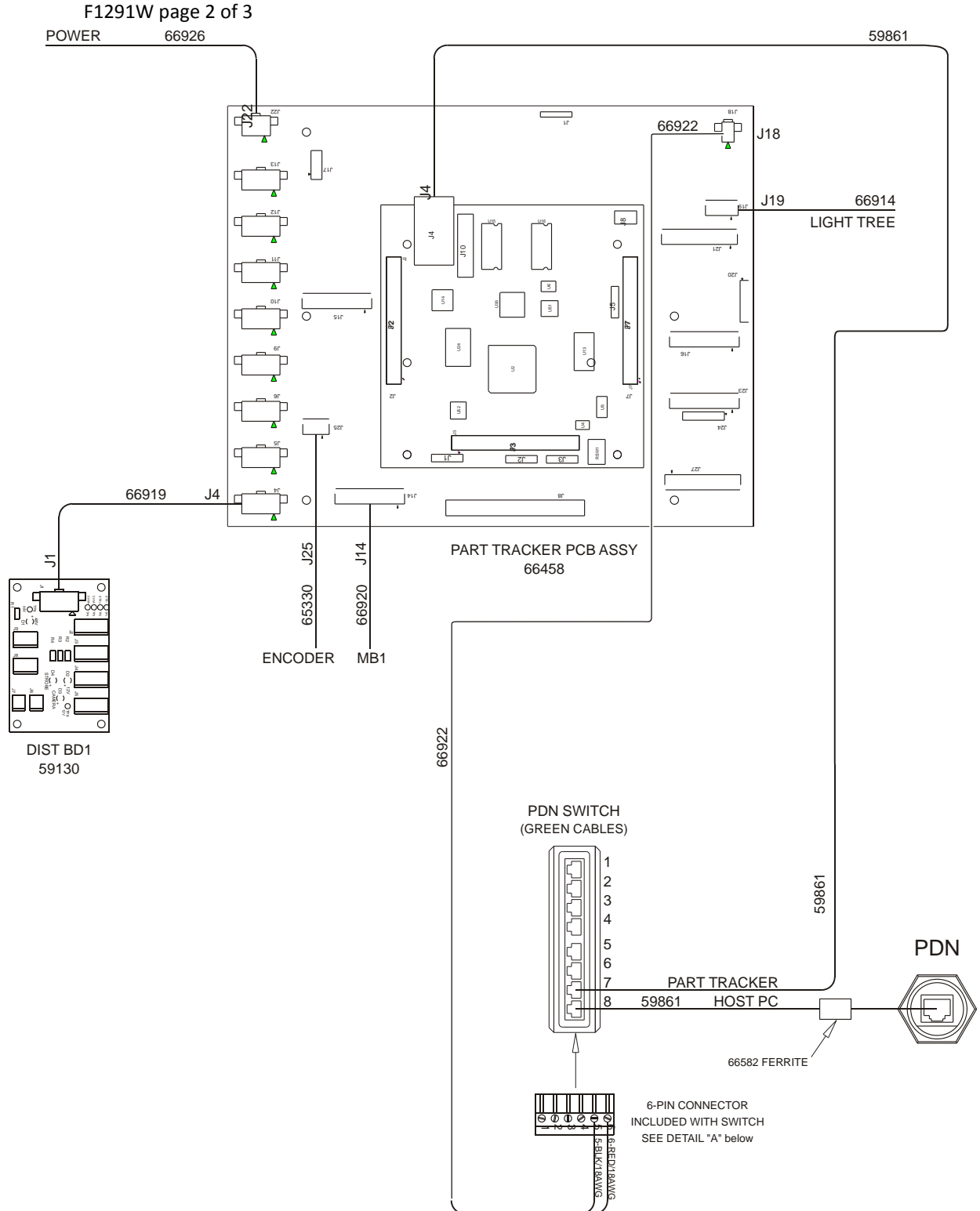

❖ Note: on Part Tracker assembly, switch RSW1 must be set to 'F' for proper operation

Detail "A"

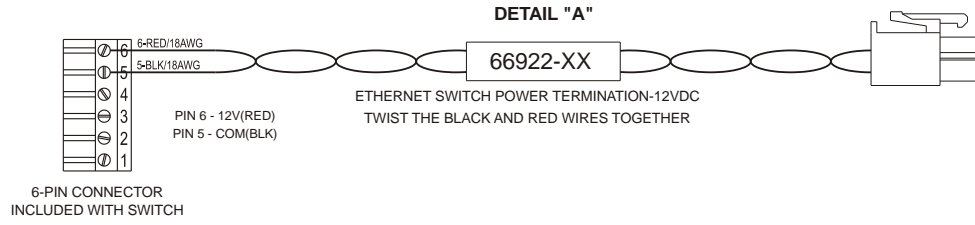

# CP4422EV internal connections page 3

F1291W page 3 of 3

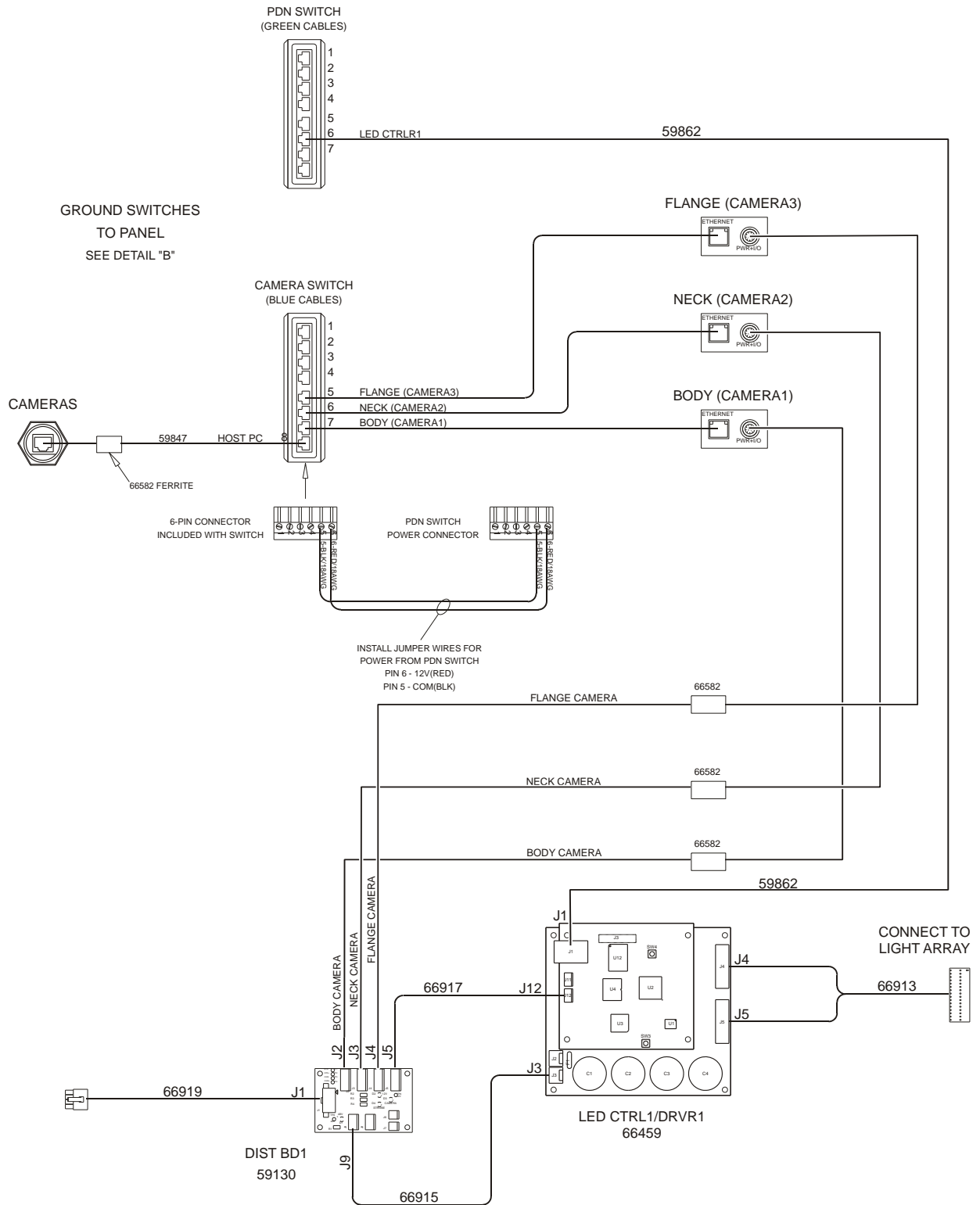

Detail "B"

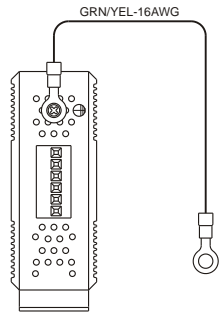

DETAIL "B"

ETHERNET SWITCH GROUND  
TRIM WIRES TO FIT

**CP4422EV auxiliary module internal connections**

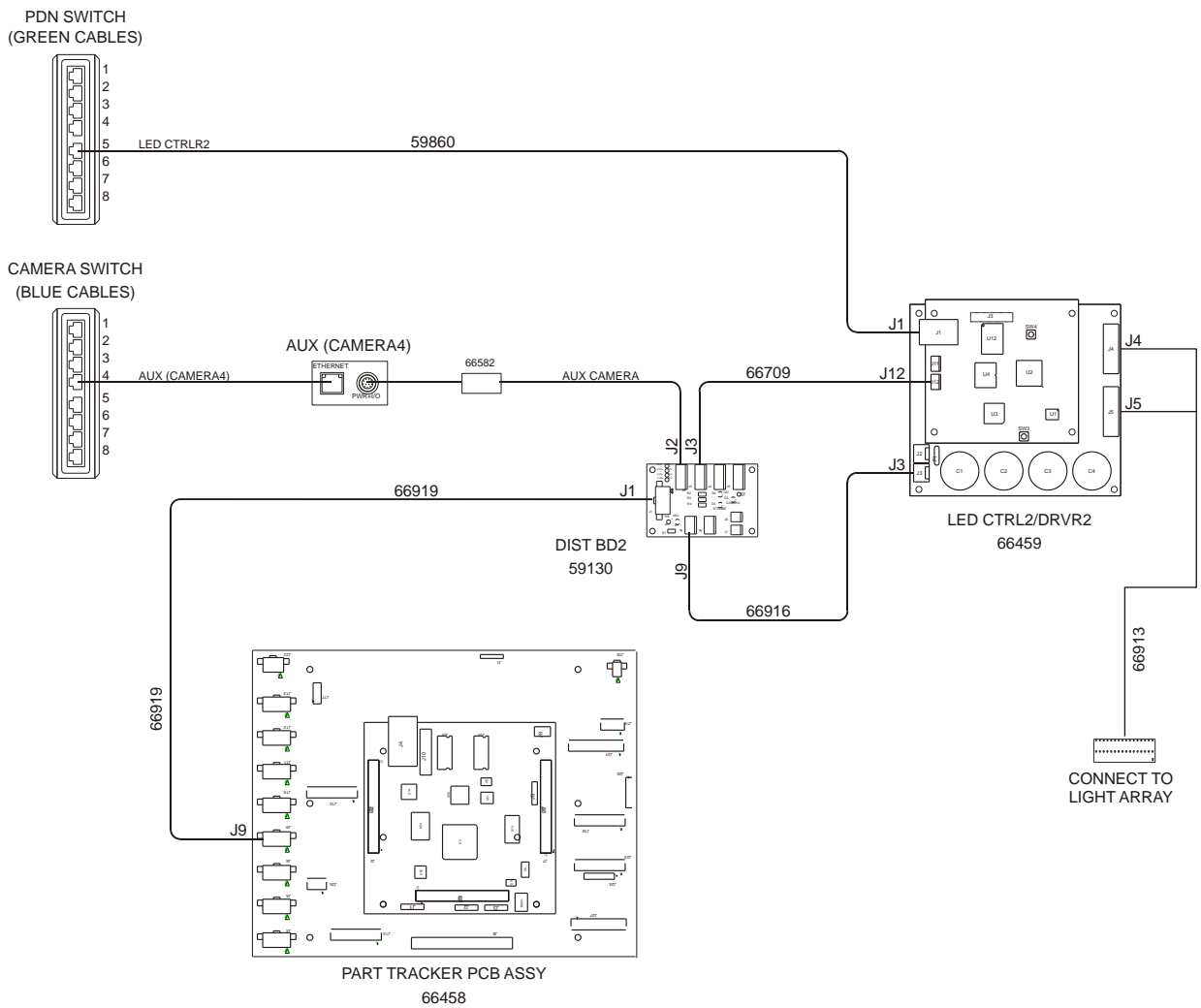

## CP500 inspection module

The CP500 inspection module is in a smaller package for confined spaces. It inspects mostly smaller crowns and closures.

The CP500 is shown below.

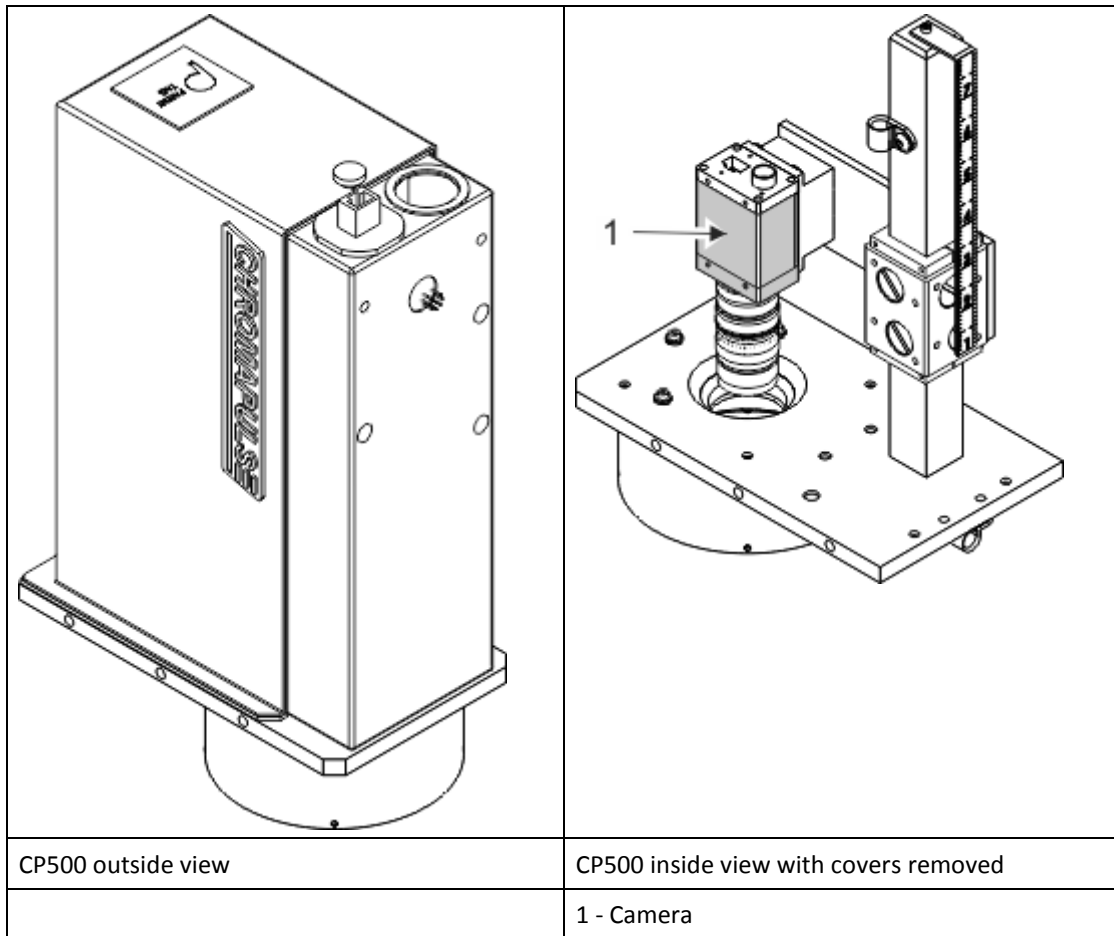

### Adjusting the CP500/ V module

#### **Camera Adjustments**

If your inspection module has the optional motorized focus and aperture feature, you can adjust the focus and aperture through the software: **Camera Focus and Aperture** (on page 136).

#### **Lighting Adjustments**

To adjust the lighting, use the software adjustments.

To see the image on the screen:

**Observe Part Image** (on page 305)

Adjust lighting through either:

- **Basic adjust lighting** (on page 141), or
- **Advanced adjust lighting** (on page 142)

Most often, you will use Basic Adjust Lighting.

## Lighting zones CP500

The lighting zones are the same as the CP500E inspection module. See *Lighting zones CP500E/ CP750E* (on page 311).

### CP500 inspection module internal connections

ASSEMBLIES W/O MOTORIZED FOCUS

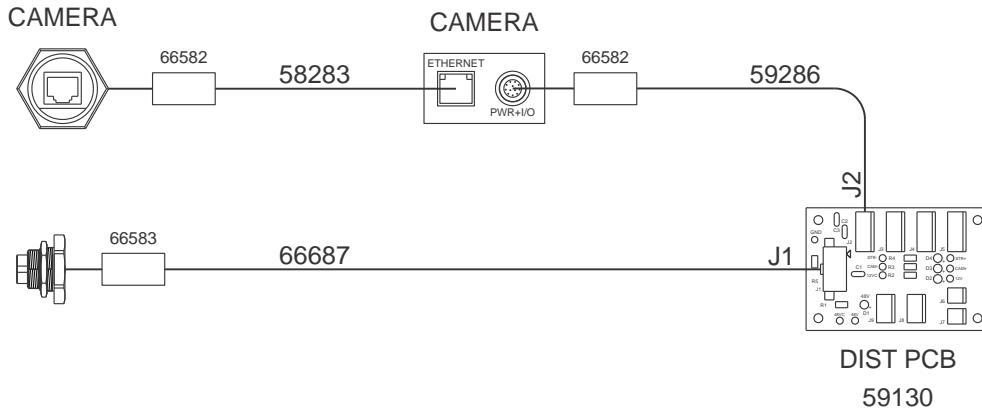

ASSEMBLIES W/ MOTORIZED FOCUS

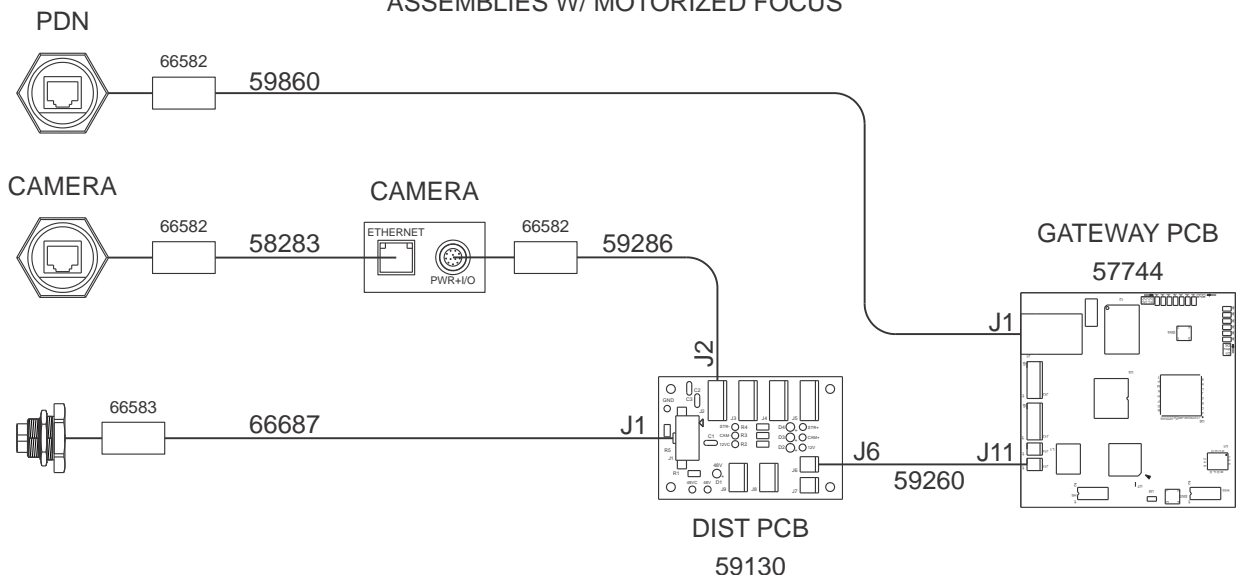

## CP500 Motorized focus connections (optional)

The following wiring diagram shows the wiring between the motors and controllers for inspection modules that have the motorized focus option.

### ASSEMBLIES W/ MOTORIZED FOCUS

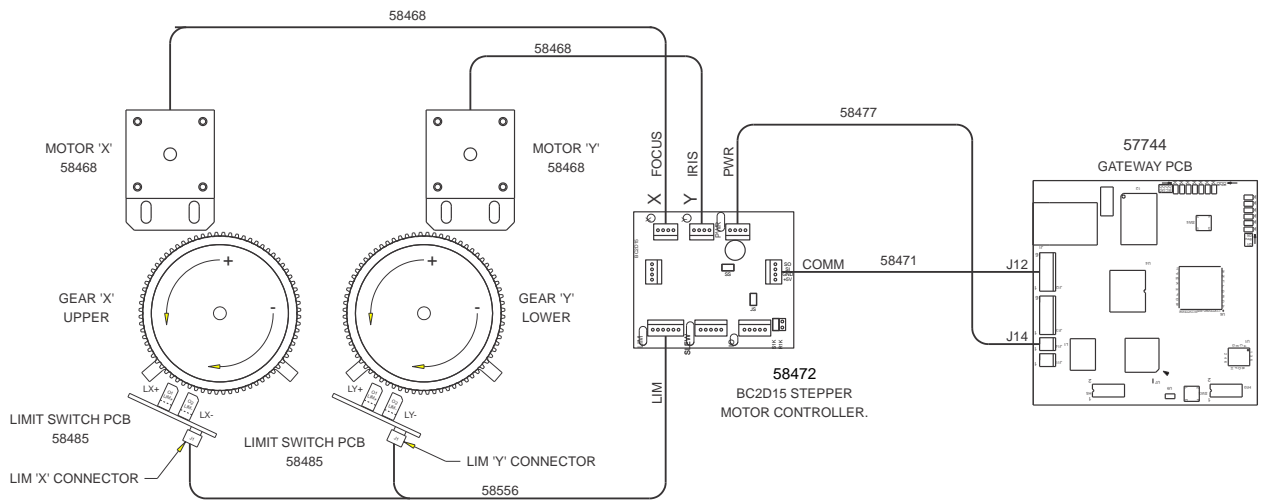

### CAMERA ASSEMBLY

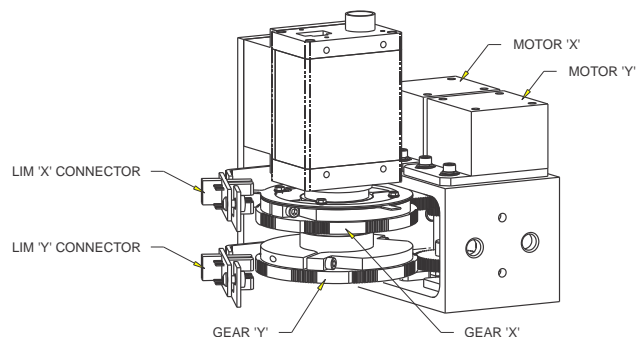

# CPX inspection module

The CPX module contains the lighting and optics to inspect the decoration on the outside of cans to detect mixed labels and gross decorator defects. The basic components of the inspection module are shown below.

## CPX front view (with door removed)

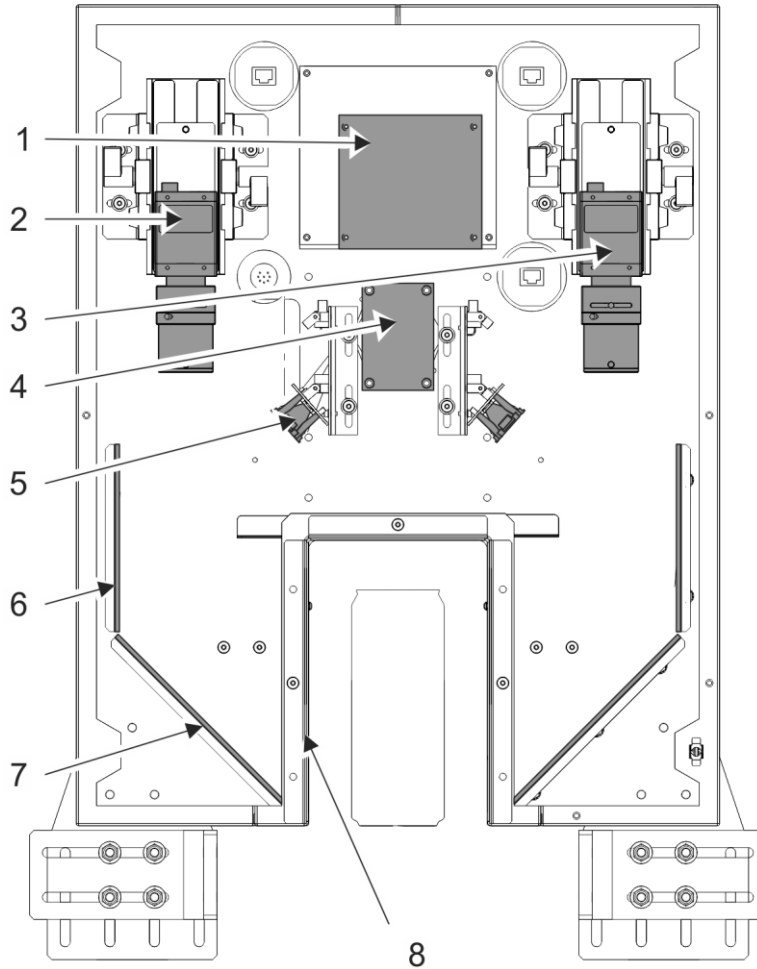

1	Light control board
2	Camera 1
3	Camera 2
4	Signal distribution board
5	LED light source (quantity 4)
6	First surface mirror for optics (one on each side of module)
7	First surface mirror for optics (one on each side of module)
8	Glass shield

### CPX back view

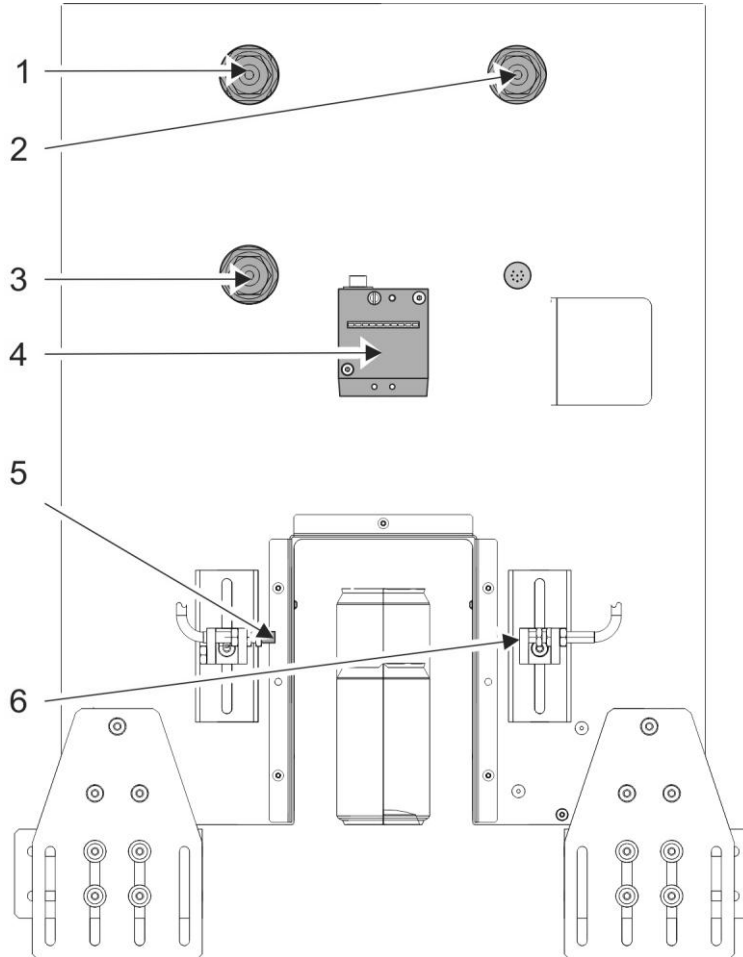

1	Blue cable - Camera 2 connector
2	Blue cable - Camera 1 connector
3	Green cable - PDN (Pressco Device Network)
4	Photoelectric sensor "Smarteye"
5	Part detector cable
6	Part detector cable

### Adjusting the CPX camera

This section covers camera adjustments that may be required to keep the inspection modules working properly. Adjustments include the camera position, aperture, and camera focus.

The focus adjustment controls the clarity of the image; the aperture adjustment controls the amount of light admitted by the shutter. Normally the inspection modules do not require further adjustment after initial system setup. Circumstances that might require additional adjustments are camera replacement, strobe replacement, or a substantial change in part size or color.



## Danger

The inspection modules are mounted near moving machinery. Use extreme caution to avoid contact with moving machinery when servicing inspection modules as serious personal injury could result. Ensure machinery is in an emergency stop state before servicing inspection modules.

The camera can be moved up or down for fine tuning the image. The focus and aperture can be adjusted manually if necessary.

❖ *Note: The camera inspects the top five inches of a can, or the whole length of a 12 ounce can. This adjustment is not for large adjustments.*

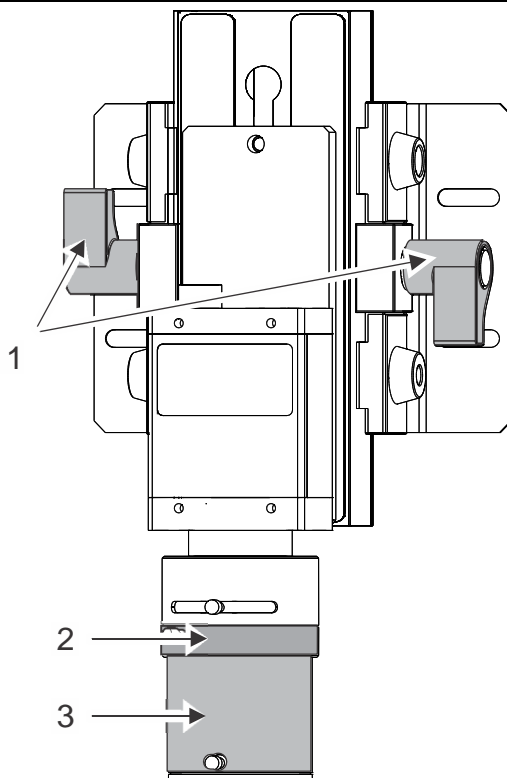

1	Camera adjust to fine tune the image area
2	Aperture adjust
3	Focus adjust

## Camera Adjustments

If your inspection module has the optional motorized focus and aperture feature, you can adjust the focus and aperture through the software: **Camera Focus and Aperture** (on page 136).

## Lighting Adjustments

To adjust the lighting, use the software adjustments.



# Chapter 16

## Extended I/O

This section contains information about the **optional** Extended I/O board.

❖ *Note: In some systems, such as FHCP 3X inspection systems, the Extended I/O board is always included (not optional).*

---

### Extended I/O board

This optional module provides additional input and output ports for communicating with the Intellispec Series V system. The board may be installed within a cluster box or within an **inspection module** (see "**Extended I/O in inspection modules**" on page 306). The board is connected to the lane's Part Tracker board via a ribbon cable.

❖ *Note: Each Extended I/O board handles only one lane.*

❖ *Note: Extended I/O is not available with an Embedded Cluster Box.*

Some signals must be enabled in the software through the **Extended I/O Configuration** (on page 344).

Below is the basic layout for the Extended I/O module.

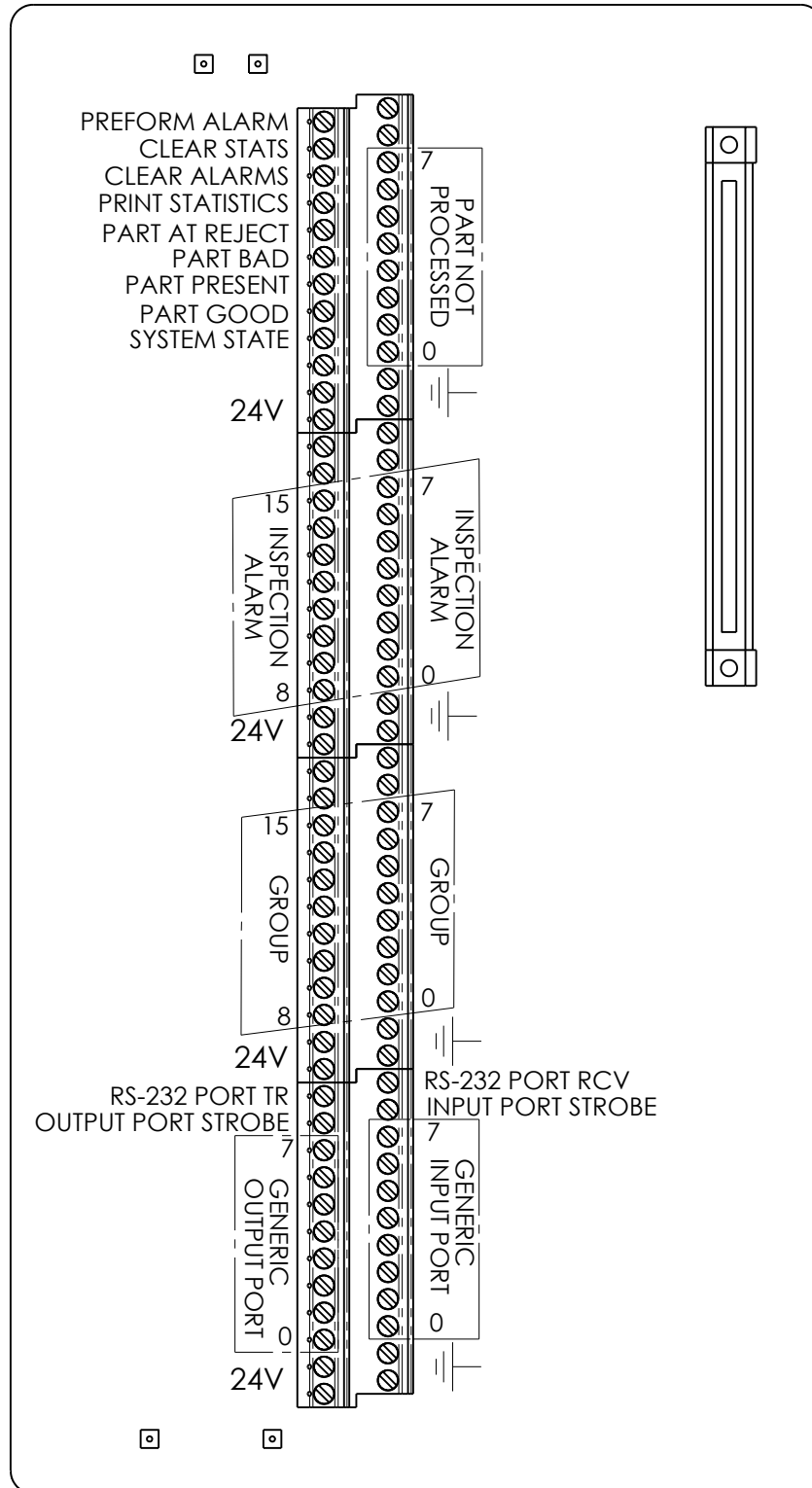

## Extended I/O signals

The Series V Extended I/O signals are listed in the table below. For the location on the Extended I/O board, refer to the **Extended I/O terminal block reference** (on page 342).

❖ *Note: some signals are not currently used*

All Extended I/O inputs are PNP. Outputs are selectable to be either open collector or open emitter. However, that selection applies to ALL output signals.

The input and power LEDs are visual indicators. The output LEDs illuminate if the current reaches 40mA or higher, which is approaching maximum current. The maximum current output is 50mA. See also information about **Extended I/O circuits** (on page 342).

\*The signals marked with an asterisk must be enabled through **Extended I/O Configuration** (on page 344) in the software.

Signal	I/O	Connector	Indicator LED	Comments/ Reference
Clear Stats*	I	J4-23	D2	Clears the lane statistics
Clear Alarms*	I	J4-22	D3	Clears the lane alarms
Print Statistics*	I	J4-21	D4	Prints the lane statistics to currently configured printer or file <b>Schedule Reports</b> (on page 88)
Preform Alarm	I	J4-24	D1	Used only in special applications. Activated by the Preform Material Handling system.
System State*	O	J4-16	D11	Indicates whether the lane is online or offline. Online = active. Offline = inactive.
Part Present (Part Detect)*	O	J4-18	D9	Pulses for 12 ms when the part present sensor detects a part
Part Good* (Group A)	O	J4-17	D7	Pulses for 12 ms for each part declared good by the inspection
Part Bad* (Group A)	O	J4-19	D5	Pulses for 12 ms for each part declared bad by the inspection
Part at Reject* (Group A)	O	J4-20	D13	Pulses for 12 ms for each part that crosses the reject point (online mode only)
Group 0	O	J2-3	D17	Pulses for 12 ms when an inspection fails in the user-defined group (online mode only) <b>Walk By Setup</b> (on page 60)
Group 1	O	J2-4	D25	
Group 2	O	J2-5	D33	
Group 3	O	J2-6	D41	
Group 4	O	J2-7	D15	
Group 5	O	J2-8	D23	
Group 6	O	J2-9	D31	
Group 7	O	J2-10	D39	
Group 8	O	J2-15	D21	
Group 9	O	J2-16	D29	
Group 10	O	J2-17	D37	
Group 11	O	J2-18	D45	
Group 12	O	J2-19	D19	

Signal	I/O	Connector	Indicator LED	Comments/ Reference
Group 13	O	J2-20	D27	
Group 14	O	J2-21	D35	
Group 15	O	J2-22	D43	
Part Not Processed: (Rejector 0)	O	J4-3	D109	Pulses for 12 ms when a part is not processed due to a system malfunction (online mode only)
Part Not Processed: (Rejector 1)	O	J4-4	D113	
Part Not Processed: (Rejector 2)	O	J4-5	D117	
Part Not Processed: (Rejector 3)	O	J4-6	D121	
Reject Confirm 0	O	J4-7	D107	Output signal when reject is confirmed (F168 and later DPT firmware)
Reject Confirm 1	O	J4-8	D111	
Reject Confirm Sensor blocked	O	J4-9	D115	Reject confirm sensor signal pulse width exceeding programmed limit (F168 and later DPT firmware)
Host communication lost	O	J4-10	D119	Output signal when communication to/from host is disrupted (F168 and later DPT firmware)
Inspection Alarm 0	O	J3-3	D59	Pulses when the associated alarm condition occurs and stays active until the alarm is cleared <b>Lane Alarm Configuration</b> (on page 76) and <b>Sensor Alarm Configuration</b> (on page 80) *J3-22 Inspection Alarm 15 supported with F168 and later DPT firmware. In earlier firmware versions, this signal is "Host Communication Lost"
Inspection Alarm 1	O	J3-4	D67	
Inspection Alarm 2	O	J3-5	D75	
Inspection Alarm 3	O	J3-6	D83	
Inspection Alarm 4	O	J3-7	D57	
Inspection Alarm 5	O	J3-8	D65	
Inspection Alarm 6	O	J3-9	D73	
Inspection Alarm 7	O	J3-10	D81	
Inspection Alarm 8	O	J3-15	D63	
Inspection Alarm 9	O	J3-16	D71	
Inspection Alarm 10	O	J3-17	D79	
Inspection Alarm 11	O	J3-18	D87	
Inspection Alarm 12	O	J3-19	D61	
Inspection Alarm 13	O	J3-20	D69	
Inspection Alarm 14	O	J3-21	D77	
Inspection Alarm 15*	O	J3-22	D85	
Generic Input Port 0	I	J1-3	D48	Reserved for Asynchronous Correlation
Generic Input Port 1	I	J1-4	D50	
Generic Input Port 2	I	J1-5	D51	

Signal	I/O	Connector	Indicator LED	Comments/ Reference
Generic Input Port 3	I	J1-6	D52	
Generic Input Port 4	I	J1-7	D55	
Generic Input Port 5	I	J1-8	D56	
Generic Input Port 6	I	J1-9	D47	
Generic Input Port 7	I	J1-10	D49	
Input Port Strobe	I	J1-11	D53	Reserved for Asynchronous Correlation
Generic Output Port 0	O	J1-15	D91	Reserved for Asynchronous Correlation
Generic Output Port 1	O	J1-16	D95	
Generic Output Port 2	O	J1-17	D101	
Generic Output Port 3	O	J1-18	D105	
Generic Output Port 4	O	J1-19	D89	Encoder Z pulse output
Generic Output Port 5	O	J1-20	D93	Part at Reject (Group B)
Generic Output Port 6	O	J1-21	D99	Part Bad (Group B)
Generic Output Port 7	O	J1-22	D103	Part Good (Group B)
Output Port Strobe	O	J1-23	D97	Reserved for future use
RS-232 Port TR	O	J1-24	D202	Reserved for future use
RS-232 Port RCV	I	J1-12	D200	Reserved for future use

### **All Connectors**

Function	Pin
Isolated ground	1, 2
24 V (isolated)	13, 14

### **Test Points**

Function	Test Point
24 V	2
24 V Gnd	3
3.3 V	1
3.3 V Gnd.	4

# Extended I/O terminal block reference

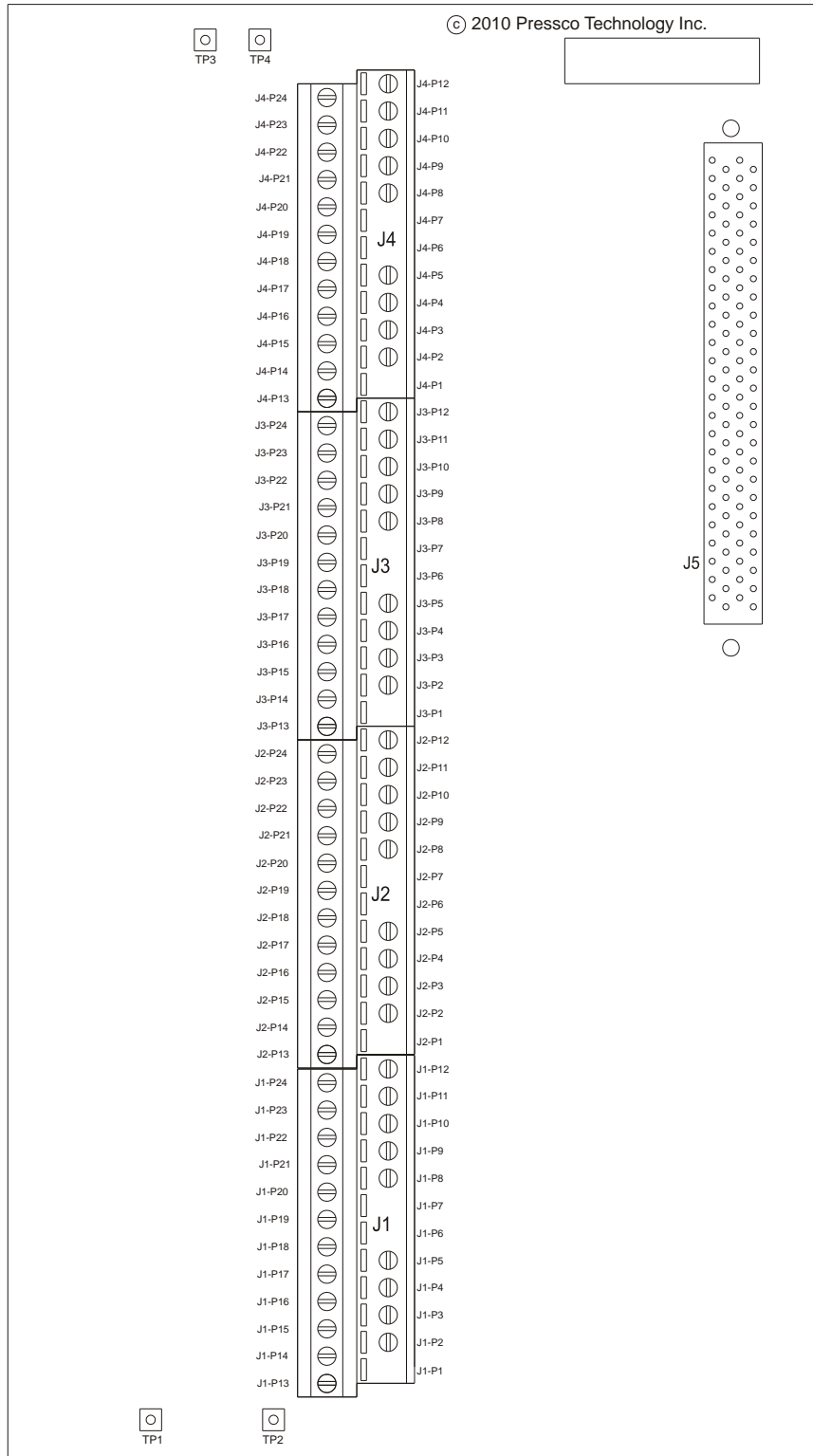

## Extended I/O circuits

The following illustrations show typical input and output circuits you can use to communicate with your plant's PLC, or to connect external LEDs or light trees.

### ➤ Specifications:

- Minimum dwell time of the **input** device is 1.1 ms
- Maximum **output** load is 50 mA
- Default value of **output** pulse is 12ms. Some output signals, such as alarms, must be cleared on the Intellispec before they turn off.

### Default timing of pulsed output

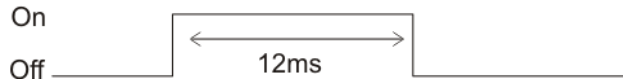

The following illustration shows a typical circuit that can be used to clear alarms.

### CLEAR ALARMS - INPUT

Terminal Block TB4

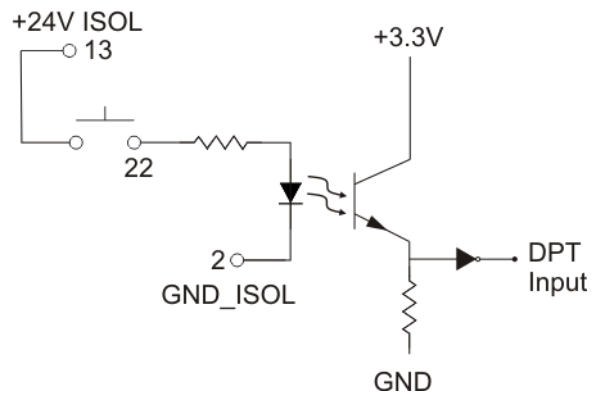

The following illustration shows a typical circuit that can be used for a group output.

### GROUP 1 - OUTPUT

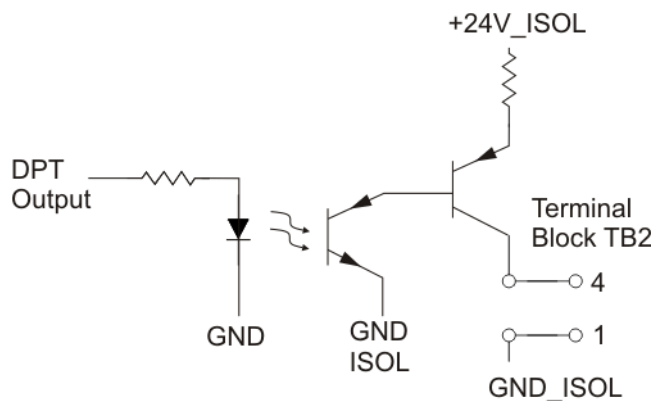

## Extended I/O in inspection modules

The *Extended I/O* (see "*Extended I/O board*" on page 337) kit (optional) is installed within Chromapulse inspection modules as shown below.

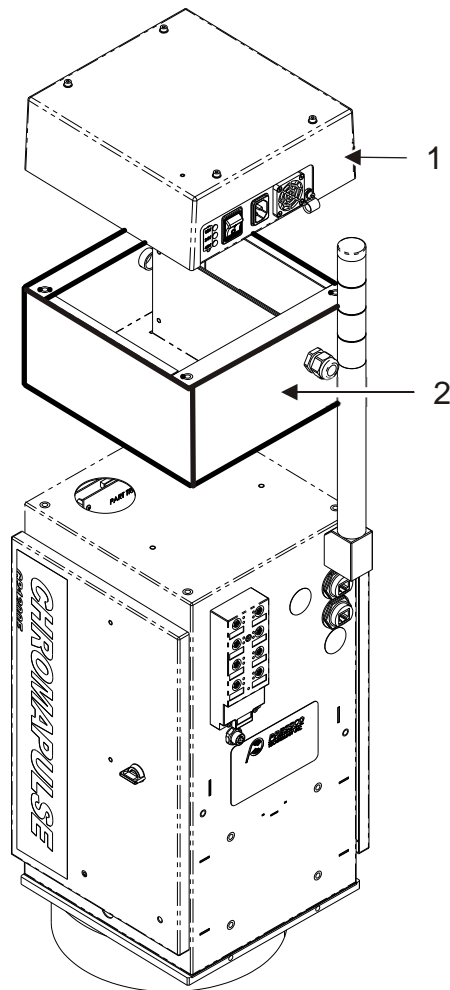

1	power cap
2	Extended I/O kit

## Extended I/O Configuration

Through this menu you can enable input or output signals to either perform a function on the Intellispec system or allow you to monitor the production lane in your plant. These settings must be done for each Extended I/O board for each lane.

See also the sections about *Extended I/O* (see "*Extended I/O board*" on page 337) and *Extended I/O Signals* (on page 338).

### ➤ To get to this screen:

From the Lane or Sensor Overview screen, click the Tools button  to see the Tools Menu, then select Hardware Setup, then select Extended I/O Configuration.

This screen displays some of the inputs and outputs on the optional extended I/O board.

If one of the extended I/O ports is used it must be enabled here in the software, and the hardware must be connected appropriately.

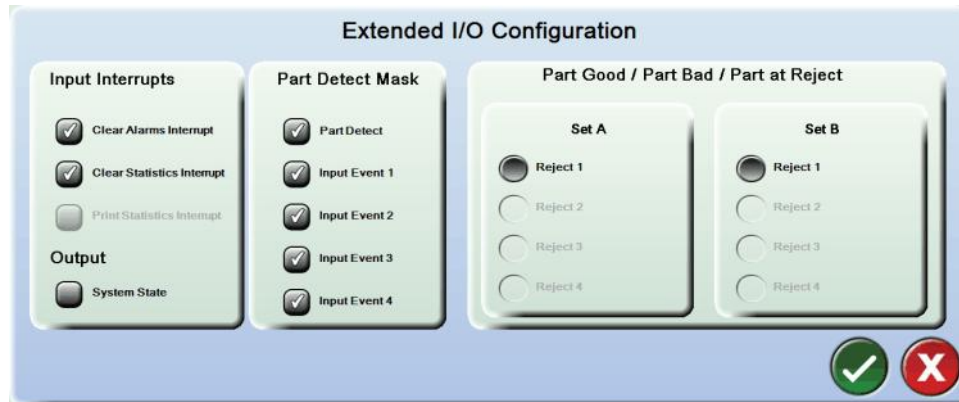

## **Input Interrupts**

These signals produce an input pulse to the Intellispec processor to perform the following functions.

### **Clear Alarms Interrupt**

Clears the lane alarms.

### **Clear Statistics Interrupt**

Clears the lane statistics.

### **Print Statistics Interrupt**

Prints the lane statistics to the currently configured printer or file. See also **Schedule Reports** (on page 88).

## **Output**

### **System State**

Produces an output pulse to notify your plant whether the lane is online or offline. Online = active. Offline = inactive.

## **Part Detect Mask**

Choose which Part Detect or other input events to trigger the Part Present output on the Extended I/O board. This is an OR function. Any enabled Part Detect signal or Input Event that goes active will activate the Extended I/O Part Present output.

### **Part Detect**

The signal goes active when the sensor detects a part.

### **Input Event N**

The Part Tracker board accepts up to five\* input events (Part detectors or other sensors). Part tracking is always controlled by the Part Detect signal (Input Event 0). You might use other input events (1 - 4) in your system to trigger the Part Present output signal.

\*Only if your system has an 8-channel Part Tracker board. If your system has a 2-channel Part Tracker board, then only one Part Detect signal is used. The other input events are not available.

## **Part Good/ Part Bad/ Part at Reject**

Choose which rejector signal to activate the **Part Good**, **Part Bad**, and **Part at Reject** signals on the Extended I/O board. After a part is inspected, the system determines whether the part is good or bad. As the part passes by Rejector 1, 2, 3, or 4, the Part Good/ Part Bad/ and Part at Reject signals are activated on the Extended I/O board. There are two groups of Part Good/ Part Bad/ and Part at Reject signals - Group A and Group B. You choose which rejector is associated with Group A and/or Group B. You can have both groups associated with the same rejector, if desired. See **Extended I/O signals** (on page 338).

❖ *Note: If your system has a 2-channel Part Tracker board, then the lane has up to two rejectors. If your system has an 8-channel Part Tracker board, then the lane has up to four rejectors.*

Example 1 below: Group A is triggered when the part passes Rejector 2, and Group B is triggered when the part passes Rejector 4. The illustration below shows a basic block diagram with a conveyor with four rejectors. Those rejectors output a signal to the Extended I/O board, based on the Extended I/O configuration.

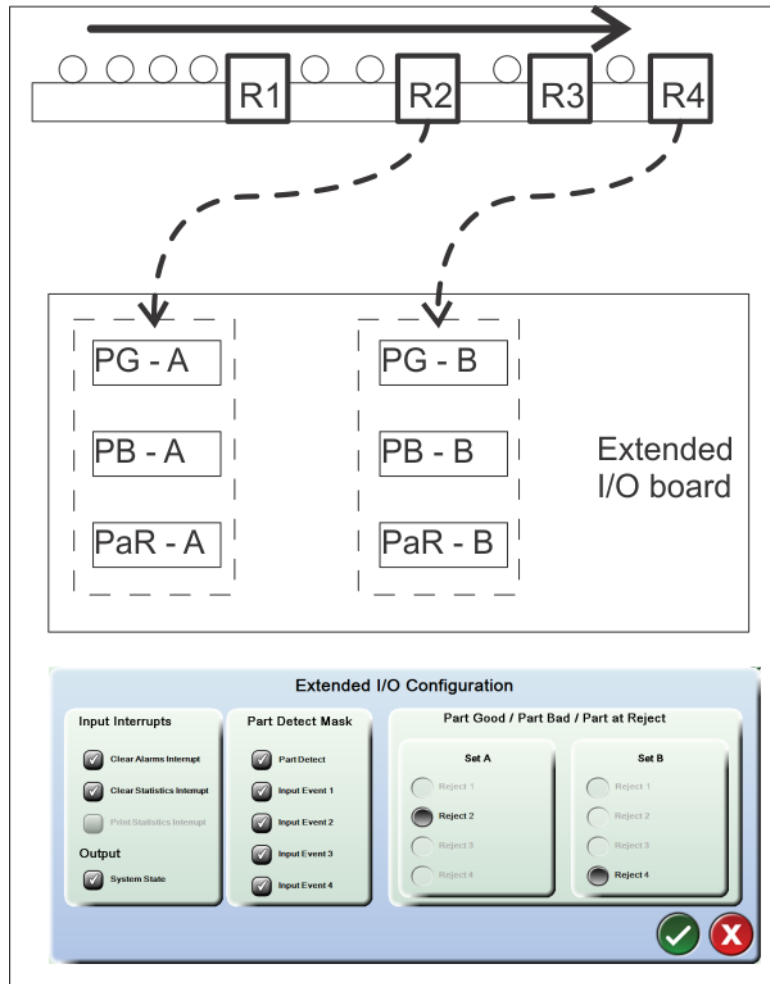

R	Rejector
PG	Part Good signal, Group A and Group B
PB	Part Bad signal, Group A and Group B
PaR	Part at Reject signal, Group A and Group B

Example 2 below: Group A is triggered when the part passes Rejector 2, and Group B is also triggered when the part passes Rejector 2.

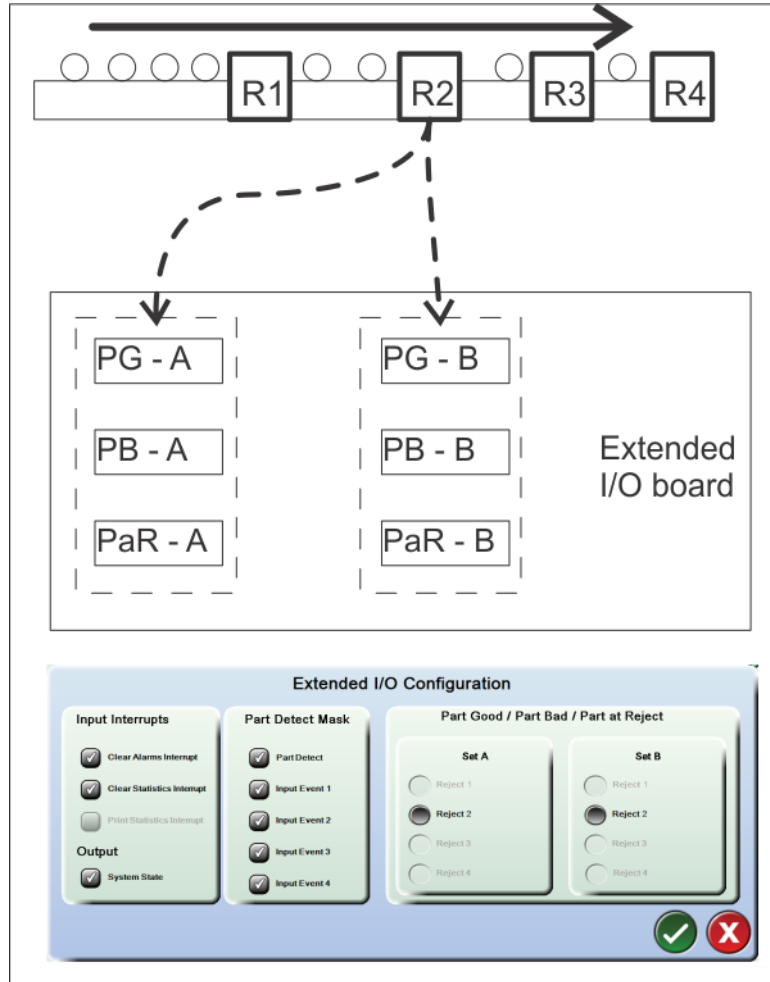



# Chapter 17

## Maintenance Frequency

Follow the guidelines for cleaning and maintenance of the Intellispec Series V CSL system and the inspection modules.

Intellispec Series V CSL enclosure and General Components			
Item	Description	Once per day or shift	Once per month
Observe Proper inspection	Verify that defective parts are being rejected by inserting a known defective part through inspection	X	
Observe Proper inspection	Verify that no stray parts are stuck in or near the inspection module or reject station	X	
Observe Proper inspection	Verify that no buildup of dirt or contaminants has occurred on inspection module, part detector, or conveyor. Clean if necessary.	X	
Observe Proper inspection	Verify that each sensor image is properly centered, focused, and properly lit. Adjust if necessary.	X	
User Interface Enclosure filter	Rinse in clean water; use mild soap and water solution if oily. <b>Cleaning the User Interface Enclosure filter</b> (on page 350)		X

Inspection Modules Chromapulse			
Item	Description	Once per day or shift	Once per month
Part Detect Sensor and Reflector	Clean with soft, clean, oil-free cloth dampened with mild soap and water solution. Wipe dry. <b>Cleaning the Part Detector</b> (on page 354)	Once per week	
Camera lens	Clean only with lens tissue and lens cleaner. Be careful not to alter focus or aperture. <b>Cleaning the Camera Lens</b> (on page 353)		X
Glass surfaces: Beam Splitter and Secondary lens	Clean with soft, clean, oil-free cloth dampened with lens cleaning solution. <b>Cleaning the Chromapulse Beam Splitter</b> (on page 352)		X
Ellipsoidal mirror	Normally does not need cleaning. If dirty, blow off dust with compressed air, and follow instructions. <b>Cleaning the Ellipsoidal Mirror</b> (on page 354)		Only if dirt appears on image
Plastic surfaces: Dome light or Ring light diffusers	Clean with soft, clean, oil-free cloth dampened with mild soap and water solution. Wipe dry.		X

Fan filters CP4422EV	Rinse in clean water; use mild soap and water solution if oily. <b>Cleaning the Chromapulse Fan Filters</b> (see " <b>Replacing/ Cleaning the Chromapulse CP4422EV Fan Filters</b> " on page 350)		<b>X</b>
Filter/ Regulator	Replace filters <b>Replacing Filter/ Regulator Filters</b> (on page 356)	Oil removal filter - replace every <b>2000 hours</b> Oil vapor removal filter - replace every <b>12 months</b>	

## Cleaning the User Interface Enclosure filter

The filter for the user interface enclosure should be cleaned once a month for best results. The filter is located on the side of the unit. Replace with a new filter when necessary.

❖ *Note: Frequency of cleaning will depend upon plant conditions*

### ➤ To clean the filter:

1. Remove the filter [item 1] and clean it.
  - If the filter contains dry dust and dirt, rinse it in plain water
  - If the filter contains oily dust and dirt, clean it in soapy water, then rinse in clear water
2. Dry the filter completely, then place it back in the retainer.

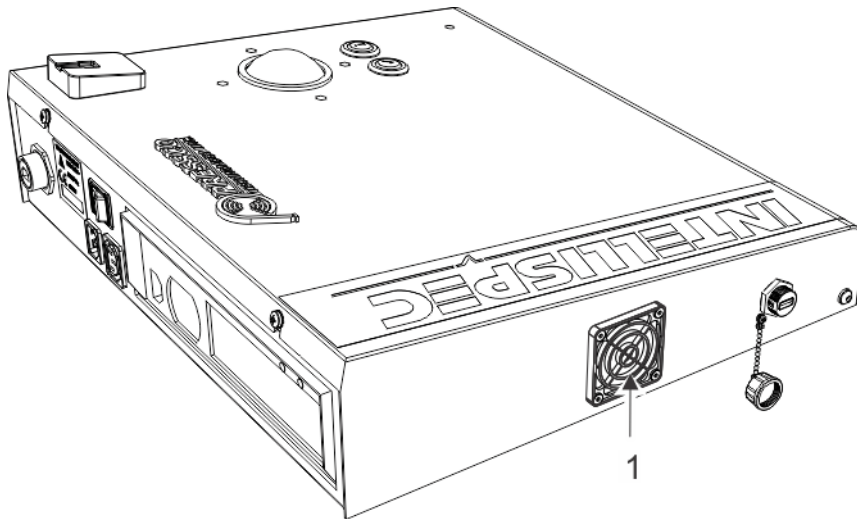

1	Part number 45355 - replacement filter
---	--

# Replacing/ Cleaning the Chromapulse CP4422EV Fan Filters

We recommend that you replace the filters once a month, using the part number listed below.

If you do not have replacement filters, clean them once per month. Remove the covers to access the filters.

- If the filter contains only dry dust and dirt, rinse it in plain water
- If it contains oily dust and dirt, clean it in soapy water

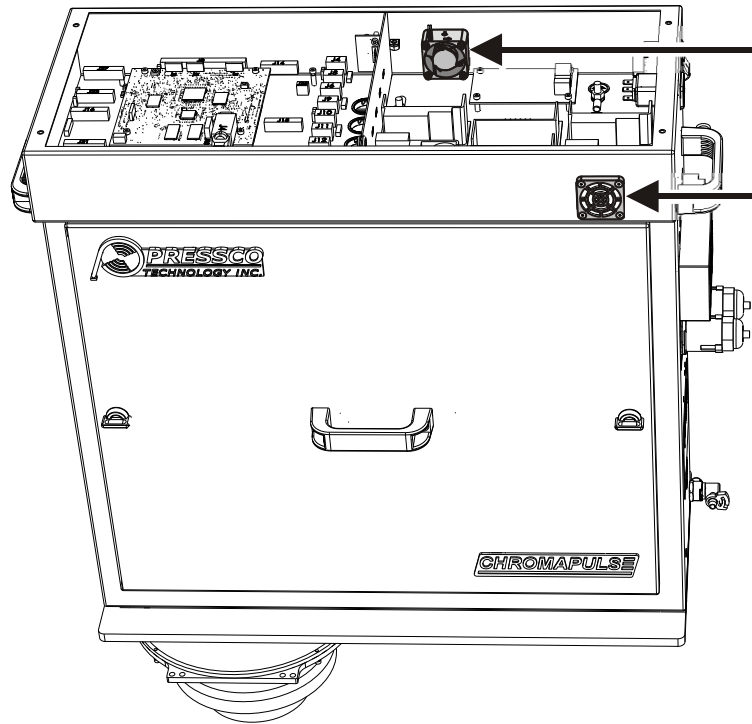

To replace a filter, use the part number listed below:

	Part Number	Description
1	66446	Replacement filter element (same part number is used in both locations)

## Cleaning Optical Surfaces



### Important

Debris and contamination could build up on both the glass and plastic surfaces. This dirt could appear in the inspection windows, causing false rejects of parts, or it could degrade lighting.

Clean glass and plastic surfaces often to avoid false rejects.

To maintain proper image quality and system performance, the clear glass and plastic surfaces on the Inspection Modules must be cleaned on a regular basis. Dirt and debris that appear in the image can cause false rejects. An oily film on optical surfaces can cause false rejects or missed defects.

# Cleaning Glass Surfaces

Glass surfaces that may require cleaning are:

- Camera Lens
- Beam Splitter (if present)
- Secondary lens (if present)
- Secondary mirror (if present)

➤ **To clean glass surfaces:**

- Blow off dust with canned, compressed air
- Use a clean non-abrasive cloth dampened with lens cleaning solution
- Use lens tissue and lens cleaning solution on camera lenses
- If surface has compound on it, first clean with alcohol, then with lens cleaning solution

❖ *Note: Cleaning frequency will depend on plant and process conditions.*

## Cleaning the Chromapulse Beam Splitter

You must remove the Beam Splitter (on some Chromapulse models) to access the bottom side for cleaning. The method for removing the beam splitter depends on your inspection module.

In the illustration below, item A is used in preform sidewall endcap (PSE) modules. Item B is used in seal surface modules and some Chromapulse modules (example: CP750EV, CP1200EV, and more).

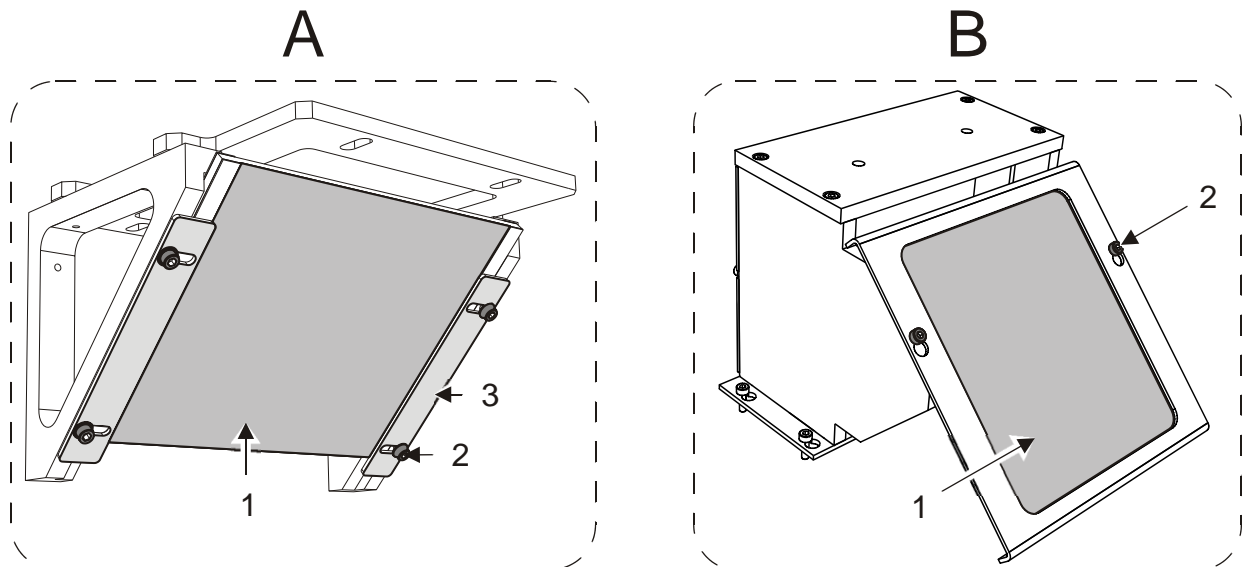

1	Beam Splitter
2	Screws
3	Retaining plates

➤ **To clean beam splitter:**

1. **Raise the camera** (see "**Cleaning the Camera Lens**" on page 353) if necessary. Be sure to note the camera position before moving it.
2. Loosen the screws [item 2] and carefully remove the beam splitter.
  - **Item A** has four screws. Slide the retaining plates [item 3] to the sides and remove the beam splitter.
  - **Item B** has two screws. Loosen the screws to remove the beam splitter.

3. Clean the beam splitter [item 1].
  - Blow off dust from beam splitter with canned, compressed air.
  - **Clean the glass** (see "**Cleaning Glass Surfaces**" on page 351) on the beam splitter.
4. Replace the beam splitter assembly.
  - **Item A** - Replace the beam splitter with the reflective side to the outside. Slide the retaining plates back in plates and tighten the screws.
  - **Item B** - Replace the beam splitter with glass to the inside. Tighten the screws.

---

## Cleaning the Camera Lens



### Caution

Do not touch the lens with fingers or oily cloths.

#### ➤ To clean the camera lens:

1. Raise the camera to access the lens by loosening the height adjustment screw. The clamping bracket should remain in place.
2. Clean all camera lenses with lens tissue and lens cleaning fluid. Be careful not to alter the focus or aperture of the cameras.
3. Slide the camera back into position as marked by the clamping bracket.
4. Tighten the height adjustment screw
5. Re-adjust aperture and focus if needed.

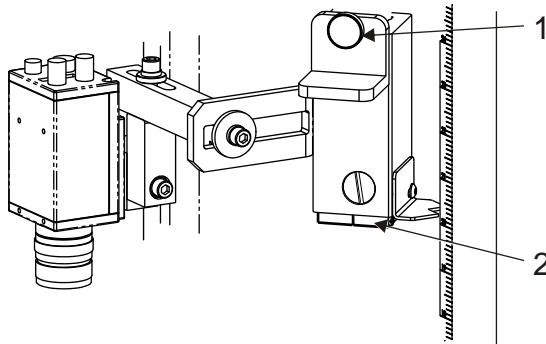

1	Camera height adjustment screw
2	Clamping bracket - camera height reference

---

## Cleaning Plastic Surfaces

Plastic surfaces that may require cleaning are:

- Dome Light Diffuser
- Ring Light Diffuser
- Light Shield (if present)
- Beam Splitter Diffuser (if present)

❖ *Note: Cleaning frequency will depend on plant and process conditions.*

➤ *To clean plastic surfaces:*

Do	Do Not
Use canned compressed air to blow away dust	Do not wipe away dirt as plastic coating may be scratched
Use a clean, non-abrasive cloth dampened with mild soap and water solution. Saturate surface completely to let particles wash away.	Do not use paper towels or paper napkins – these may scratch surfaces
Dry the surface with clean, compressed air	

## Cleaning the Ellipsoidal Mirror

This mirror provides the enhanced neck image for optimal inspection of the neck of a can.



### Warning

The special surface of the mirror can be easily scratched. Take special precautions and do not touch the surface of the mirror.

❖ *Note: This mirror does **not** require periodic cleaning. Contact Pressco Service if the mirror has dirt or marks that cannot be blown off with clean, compressed air.*

In most systems, the mirror has a built-in air cleaning system. Air is blown through the module to keep dust and debris off the mirror and out of the module. There are no bottom shields on these modules. You do not have to clean the mirror in these modules.

---

## Cleaning the Part Detector

Your system will be equipped with either a part detector or proximity sensor, depending on your application. The proximity sensor does not use a reflector. However, the cleaning procedure for either of these types of sensors is similar.

The part detect sensor and reflector surfaces of the part detector must remain clean to properly detect parts. Clean these surfaces regularly to prevent dirt and oil build-up.

➤ **To clean the part detector:**

- Clean the part detector surfaces with a soft, clean, lint-free cloth dampened with a mild soap and water solution.
- Clean the sensors on both sides of the conveyor.
- Do not use a glass cleaning solution or strong solvent on the plastic surfaces as they might be damaged.

❖ *Note: The frequency of cleaning will depend on plant and process conditions.*

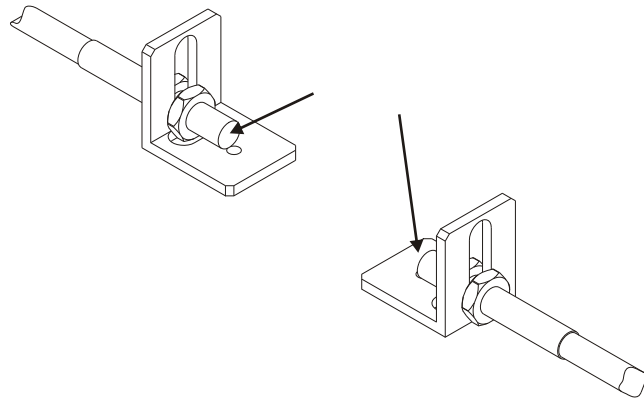

---

## Cleaning the Part Detector and Reflector

The part detect sensor and reflector surfaces of the part detector must remain clean to properly detect parts. Clean these surfaces regularly to prevent dirt and oil build-up.

Clean the part detector surfaces with a soft, clean, lint-free cloth dampened with a mild soap and water solution. Do not use a glass cleaning solution or strong solvent on the plastic surfaces as they might be damaged.

The frequency of cleaning will depend on plant and process conditions.

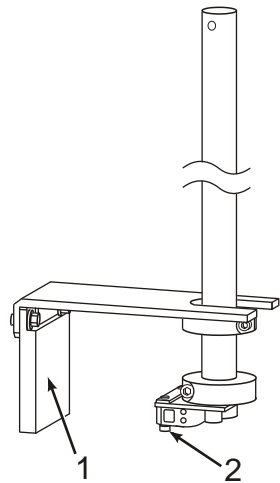

1	Part detect reflector
---	-----------------------

2	Part detect sensor
---	--------------------

# Replacing Filter/ Regulator Filters

The filter/ regulator assembly shown below is installed with CP4422EV inspection modules.

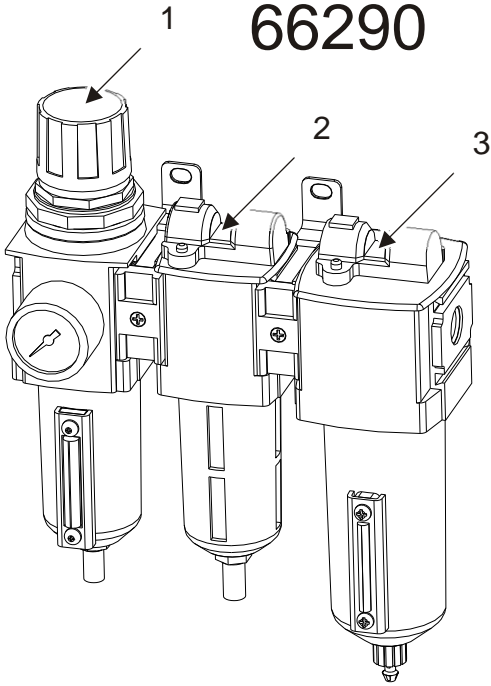

1	Filter/ regulator. No filter change necessary.
2	Filter oil coalescing
3	Filter oil vapor

Use the following part numbers and replace as indicated:

Pressco part number	Description	Use in item number (above)	Replacement frequency
67620	Filter element oil removal	2	Every 2000 hours
67621	Filter element oil vapor removal	3	Every 12 months
67622	Kit (contains one each of 67620 and 67621) <ul style="list-style-type: none"> <li>▪ You may find it easier to replace both of these filters at the same time</li> </ul>		

# Chapter 18

## About OPC

OPC (OLE {Object Linking and Embedding} for Process Control) is a data communication standard developed by leading manufacturing equipment and software vendors, in conjunction with Microsoft. Its purpose is to promote interoperability between a wide variety of data sources and the consumers of that data, eliminating the need for diverse and incompatible “drivers” for each separate device or program.

The OPC specifications are developed and administered by the OPC Foundation:

<http://www.OPCFoundation.org> <http://www.OPCFoundation.org>

Pressco has been an OPC Foundation Member since Spring of 2004, and participated in their Interoperability Workshop of April 2005.

---

## The Intellispec OPC Server

The Pressco OPC Server for Intellispec systems supports the OPC Foundation “Data Access” specification. It is compatible with all versions of the specification in widespread use today (1.0a, 2.05 and 3.00). The OPC Server does not support other OPC specifications (including Alarms & Events, Historical Data or XML Data or Unified Architecture).

The Intellispec OPC Server is an optional feature - **contact** (see "**How to Contact Pressco**" on page 373) your Pressco sales manager for details.

### Sampling rate

Sampling of data is based on an ‘update rate,’ which is specific to a group of OPC data items. There may be several groups of items, each having an update rate appropriate for the items in that group. The maximum update rate supported by the OPC Server is 100 milliseconds (i.e. 10 updates / second); this may be less depending on the system configuration, part programs and part rates. Note that OPC does NOT support event-driven data updates; example, every 10,000 parts inspected or every rotation of a machine part.

### Defect statistics

The data items available from the Intellispec OPC Server include most inspection defect statistics produced by the system. In particular, the following five items will be found:

- **TotalNumberInspected:** the number of parts inspected since last reset.
- **TotalNumberDefects:** the number of defective parts identified since last reset.
- **TotalPercentDefects:** the defective part rate expressed as a percentage of total number inspected, since statistics were last reset.
- **RecentNumberDefects:** the number of defective parts over the last “N” number of parts inspected, where “N” is a configurable system parameter.
- **RecentPercentDefects:** the defective part rate expressed as a percentage of the last “N” parts inspected, where “N” is a configurable system parameter.



These data items appear repeatedly within a hierarchical (“multi-level”) structuring of the data items and represent a variety of different subsets of the parts inspected. More specifically, they are maintained for every lane in the system (top level), every camera or sensor within each lane (second level) and every individual inspection within each camera (third level). Some values are also available for correlated machine parts when the system is so configured.

The exact names of the levels containing these data items are automatically derived from the names given to the lanes, cameras and inspections programmed into the Intellispec system. This makes “browsing the tree” of available data items extremely intuitive and eliminates the tedious and time-consuming process of OPC server configuration.

## OPC Configuration

The OPC Configuration screen provides access and settings to the OPC server.

To access OPC Configuration:

1. Log in.
2. Click the  button.
3. Click the Tools button  to see the Tools menu > select OPC Configuration. The OPC Configuration menu opens. Please see the information about each section below.

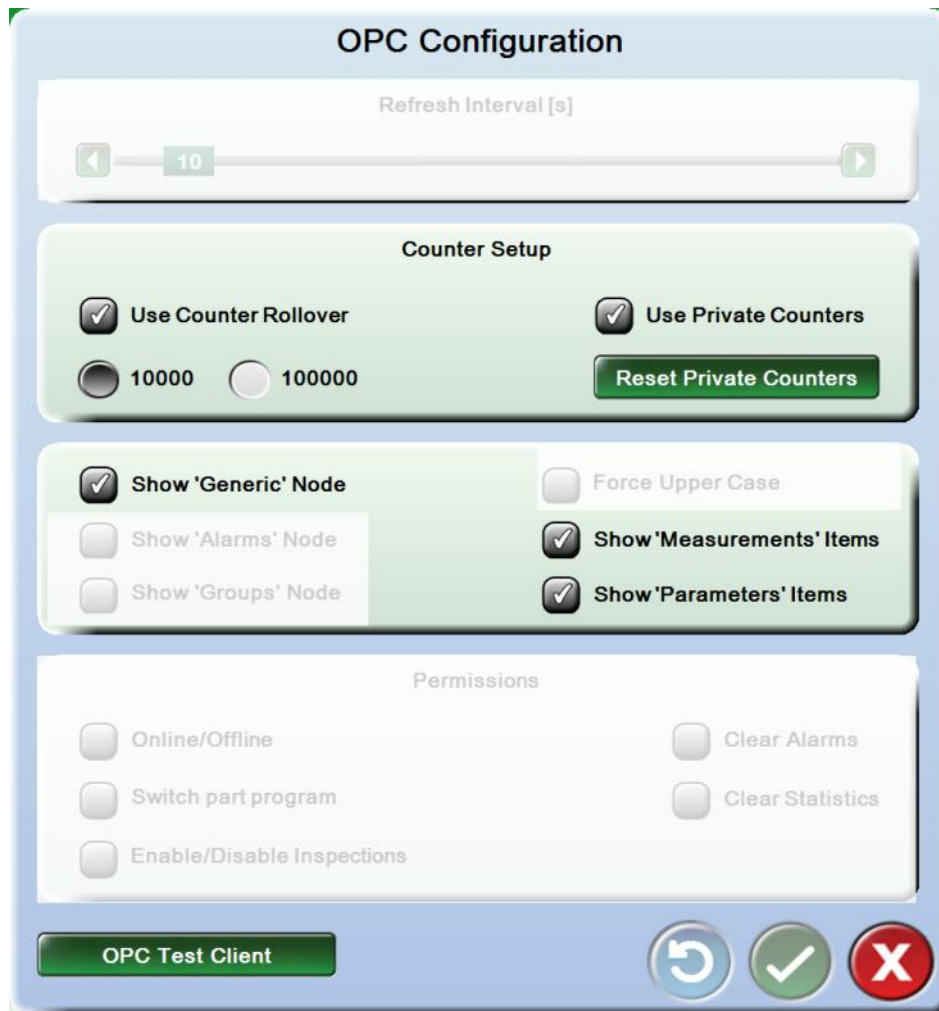

**OPC Configuration**

Refresh Interval [s]

10

**Counter Setup**

Use Counter Rollover       Use Private Counters

10000     100000      **Reset Private Counters**

Show 'Generic' Node       Force Upper Case

Show 'Alarms' Node       Show 'Measurements' Items



Show 'Groups' Node       Show 'Parameters' Items

**Permissions**

Online/Offline       Clear Alarms

Switch part program       Clear Statistics

Enable/Disable Inspections

**OPC Test Client**        

### **Refresh Interval**

Not used.

### **Counter Setup**

See **Counter Rollover** (on page 368) or **Using the OPC Private Counters option** (on page 365).

### **Options**

"Show Alarms Node" and "Show Groups Node" are not used. "Force Upper Case" is only used for compatibility with a specific OPC client - in most cases it is not used.

### Show 'Generic' Mode

Use this to view items when inspection names or other parameters have been re-named using non-ASCII characters. Note that everything is named generically, including sensors, lanes, and inspections.

❖ *Tip: This can be used by Pressco Service Engineers to view data that is not in English.*

### Show 'Measurements' Items

See **Measurement data items** (on page 363).

### Show 'Parameters' Items

See **Parameter data items** (on page 364).

### Permissions

Reserved for Pressco Technicians only.

### OPC Test Client button

Click this button to open **The Intellispec OPC test client** (on page 359).



---

## The Intellispec OPC test client

### USER LEVEL: ADMINISTRATOR

The Intellispec provides test client software to make sure that the OPC server is properly working. It is not a fully functional software client - it is only intended to be used to verify the functionality of the server. This is only available if your system has been configured for OPC.

#### ➤ To use the OPC test client:

1. Log in.
2. Click the  button.
3. Click the Tools button  to see the Tools menu > select OPC Configuration. The OPC Configuration menu opens.
4. Click the **OPC Test Client** button. The Softing OPC Toolbox Demo Client opens.
5. Click Open on the program's toolbar. The File Open dialog box is displayed.

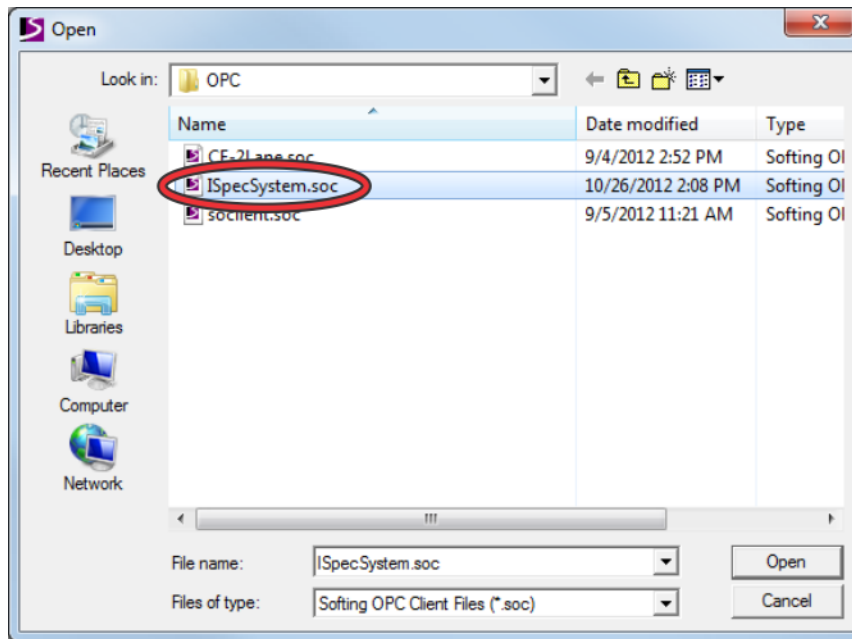

6. Click the ISpecSystem.soc file >> click Open.

- The left pane of the demo client window should now display 'Data Access' at the very top, with 'Pressco Intellispec OPC Data Server' below that, a group below that, and a list of data items (all beginning with Lane.) below the group. Each of these items (except 'Data Access') should have a solid green circle containing a black dot to the left of it.

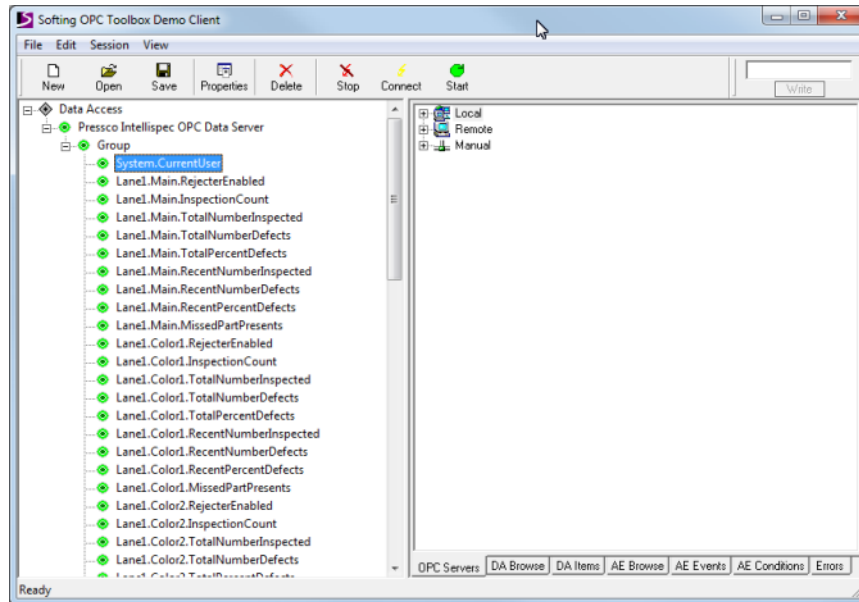

7. Click the DA Items tab at the bottom of the window. Note that there are columns for Item, Value, Quality, and Time Stamp for each of the items in the left window frame.

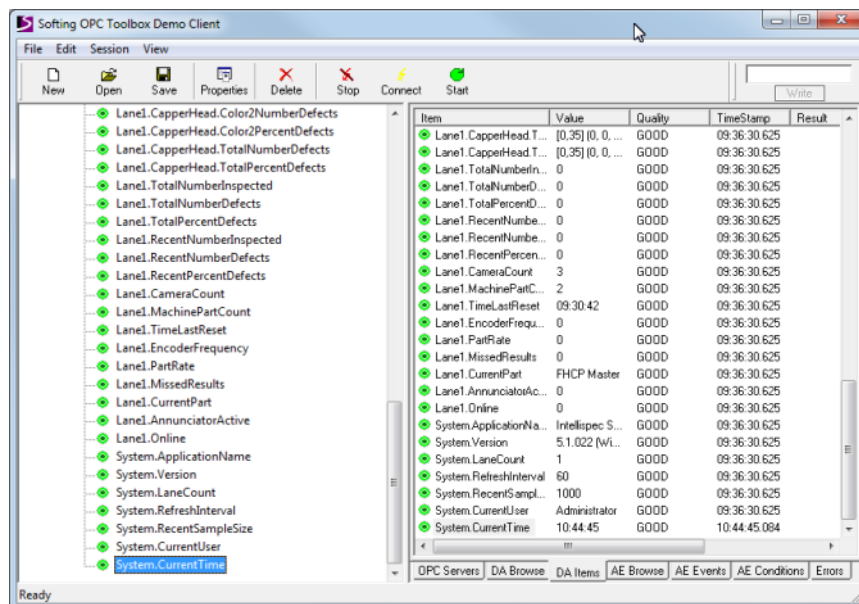

8. Verify that all data items have a solid green circle next to them.
9. Verify that all data items have GOOD status in the Quality column.
10. Verify that data item "System.Current.Time" is being updated once per second.
11. In the left window frame, select Pressco Intellispec OPC Data Server.
12. At the bottom of the right window frame, select the DA Browse tab.

13. At the top of the right window frame, click the '+' to the left of the blue diamond. There should be one blue square for each lane configured on the Intellispec, plus a blue square named System. Each blue square is a container for whatever data items are available for each group, and additional nested containers if appropriate.

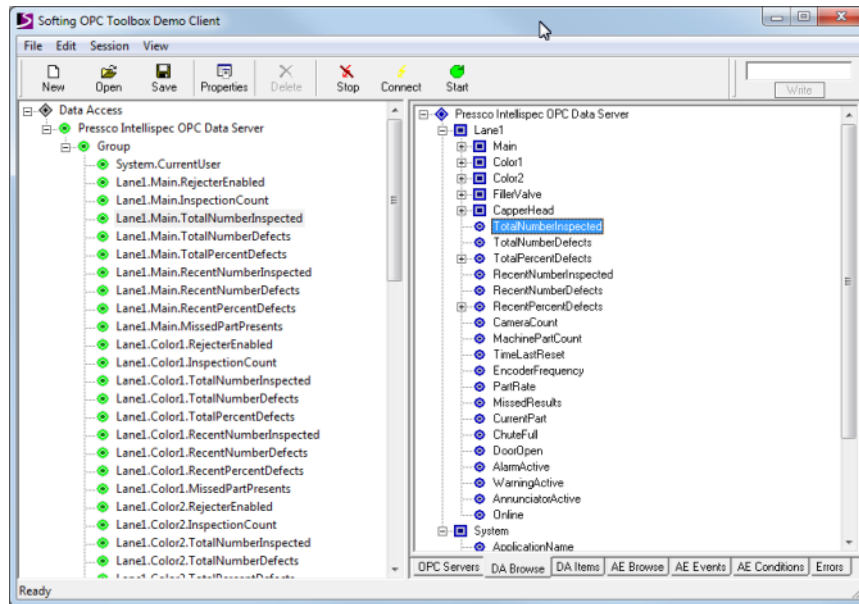

## Interpreting the Data

The data items in the OPC test client correspond to the statistics on the Intellispec screen.

➤ *To see the individual data items:*

1. Click the 'DA Browse' tab on the lower right screen.
2. Click on the '+' next to the blue square for a lane. This will display a nested blue square for each camera and machine part configured on that lane, plus several more blue circles for the data items summarizing that lane, including: TotalNumberInspected, TotalNumberDefects, TotalPercentDefects and TimeLastReset.

- Click on the '+' next to the blue square for a camera. This will display a nested blue square for each inspection currently programmed for that camera, plus several blue circles for the data items summarizing that camera. These items correspond to the statistics on the screen, as shown below.

The screenshot displays the Pressco Intellispec software interface. The top section shows 'Lane 1' with a summary table for sensors. Below this is a 'More Lane Information' section with detailed inspection data for 'Main', 'Color 1', and 'Color 2'. The bottom section shows the 'Softing OPC Tool' window with a tree view of data items. Colored arrows link specific data items in the tree view to the corresponding statistics in the main interface.

Sensor	Total	Defects	Defect %	Last N	Last N %
Main	1079	1079	100.000	979	97.900
Color 1	1079	76	7.044	69	6.900
Color 2	1079	41	3.800	38	3.800

Inspection	Total	Defects	Defect %	Last	Last N %
Tamperband	0	0	0.000	0	0.000
Fill Necks	0	0	0.000	0	0.000
Support Ring Registration	1077	0	0.000	0	0.000
Cap Height Left	1077	77	100.000	77	97.700
Cap Height Right	1077	77	100.000	77	97.700

Inspection	Total	Defects	Defect %	Last	Last N %
Neckring Reg	1077	0	0.000	0	0.000
Cap Reg	1078	55	5.102	50	5.000
Tamperband	1078	10	0.928	9	0.900
Cap Color	1078	0	0.000	0	0.000
Cap Height Left	1078	10	0.928	9	0.900

  

Inspection	Total	Defects	Defect %	Last	Last N %
Neckring Reg	1078	0	0.000	0	0.000
Cap Reg	1078	20	1.855	19	1.900
Tamperband	1079	10	0.927	9	0.900
Cap Height Left	1079	21	1.946	19	1.900
Cap Height Right	1079	11	1.019	10	1.000

- Click on the '+' next to the blue square for an inspection (example, Tamperband). This will display several more blue circles for the data items summarizing that inspection, including: Enabled, TotalNumberDefects, TotalPercentDefects, RecentNumberDefects and RecentPercentDefects.
- Click the '+' next to the blue square for a machine part (if any) (example, CapperHead). This will display a blue circle for each camera in the lane, named '<CameraName>NumberDefects', '<CameraName>PercentDefects,' plus 'TotalNumberDefects' and 'TotalPercentDefects.' Note that each of these data items is an array containing defect counts for the machine part correlation feature.

## Adding data items to those being monitored

Double-click a data item (blue circle) in the 'DA Browse' tab to add that data item to the list of those which are being monitored in the 'DA Items' tab.

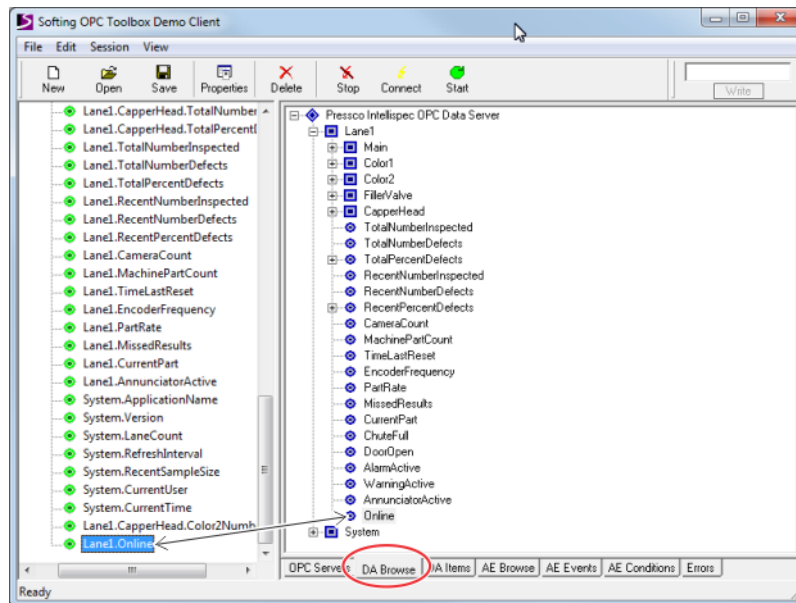

## Measurement data items

Additional inspection data is presented for some inspections.

To see measurement data items, check the **Show 'Measurements' Items** box in the **OPC Configuration** (on page 358) screen.

A number of inspections include data items providing measurements, including:

- **Measurement inspection:** the measurements "Inner," "Outer," and "Width" are available (see note 1 below)
- **Distance inspection:** the measurement "Distance" is available
- **Angle inspection:** the measurement "Angle" is available
- **Mass inspection:** the measurement "Value" is available (see note 2 below)

❖ *Note 1: some of the measurements for the "Measurement" inspection may not be active, depending on the specific configuration of the inspection.*

❖ *Note 2: if machine part correlation is available on the system, the single "Value" measurement will instead be named "AllCavities" and the per-cavity measurements "Cavity1," "Cavity2," "Cavity3," ... "Cavity(N)" where (N) is the total number of cavities configured will also be available.*

For each available measurement, the data items “Average,” “StdDev,” “Minimum,” and “Maximum” are presented, based upon a running sample of the last 100 good parts inspected while online. The following example shows the items for a Measurement inspection.

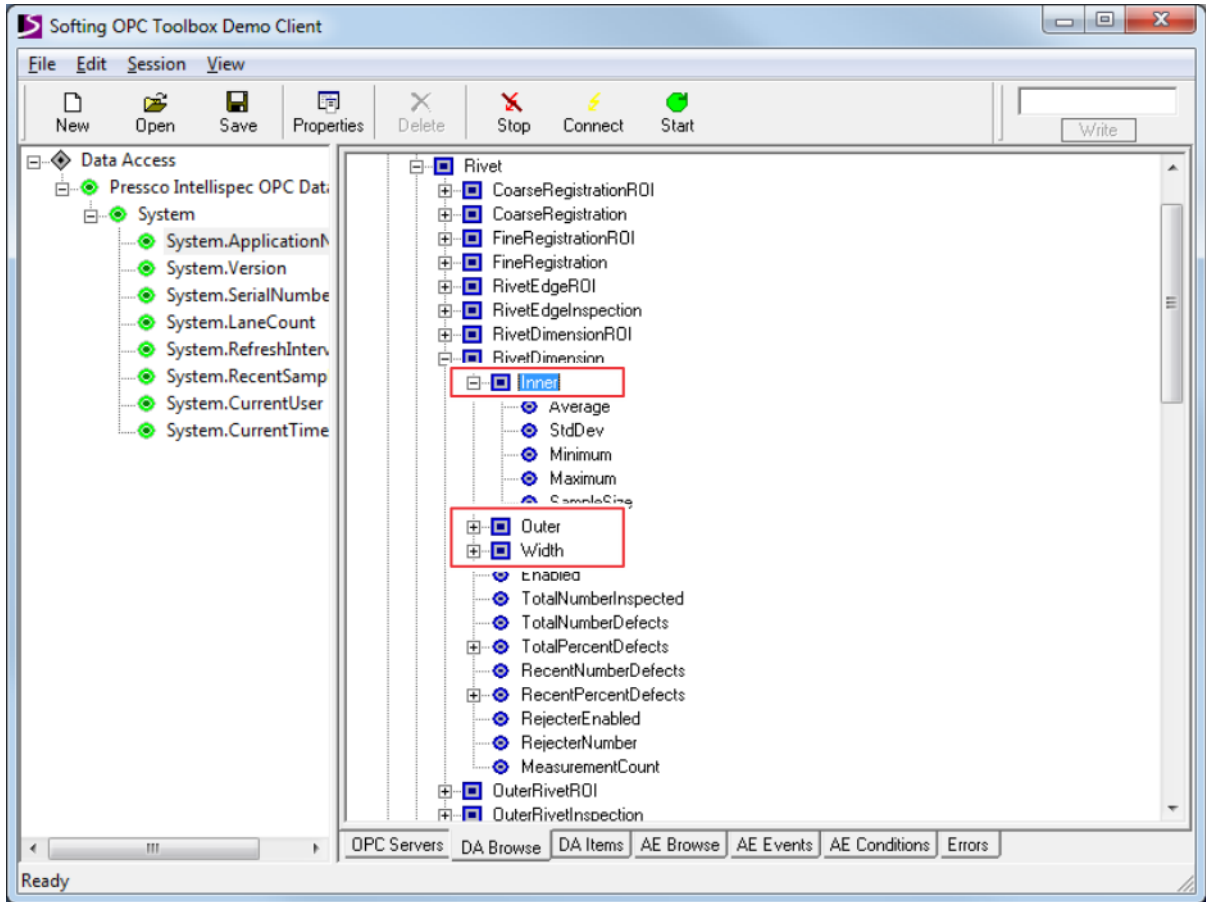

## Parameter data items

Additional inspection data is presented for some inspections.

To see parameter data items, check the **Show 'Parameters' Items** box in the *OPC Configuration* (on page 358) screen.

Contrast inspection includes parameter values (user settings affecting the performance of the inspection), including: “MaxContrast,” “MinFeatureSize,” “MaxFeatureSize,” and “MaxTotalSize” are presented. An example of a Contrast inspection is shown below.

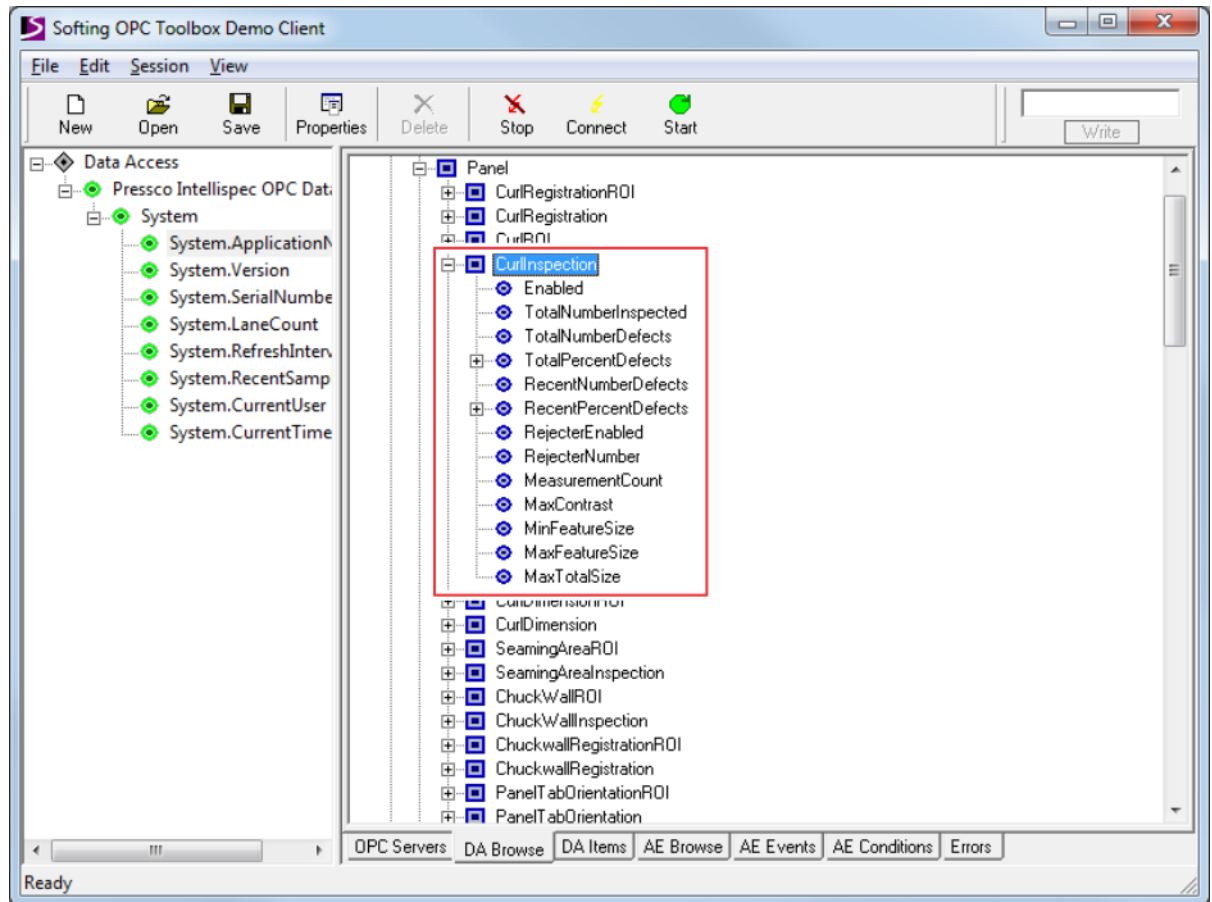

## Checking for Errors

At the bottom of the right window frame, click the Errors tab. Verify that no errors have been reported.

## Exiting the Test Client

Click the ‘X’ in the upper right corner of the Softing OPC Toolbox Demo Client window to close the program. If you are prompted to save changes (probably due to changing the list of data items being monitored), click No.

## Using the OPC Private Counters option

A separate set of OPC counters is available for long-term statistics tracking. When this feature is **enabled**, OPC counters are unaffected when the system statistics are reset either manually or automatically. When this feature is **not enabled**, the OPC counters are reset the same as the system statistics you see on the Intellispec screen.

When the Private Counters option is enabled, the OPC Counters will only reset when:

- A new part program is loaded, or:
- You use the Reset Private Counters button

### ➤ To enable the OPC Private Counters:

1. Log in as Administrator.
2. Click the  button.

3. Click the Tools button  to see the Tools menu > select OPC Configuration from the menu. The **OPC Configuration** (on page 358) menu is displayed.
4. Check the Use Private Counters box.
5. Click the OK button to save changes and exit.
6. The Intellispec must re-start for changes to take effect. Click the OK button (check mark) to acknowledge the message.

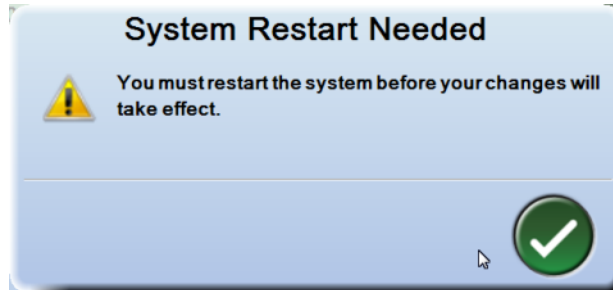

7. Click the Tools button  to see the Tools menu > select Exit System from the menu.
8. Select "Shut Down Intellispec and Restart Computer" from the drop-down menu. The Intellispec system shuts down and restarts. The Private Counters are enabled.

To see the difference between the statistics on the Intellispec screen and the OPC Private Counters, use **The Intellispec OPC test client** (on page 359).

To view only items such as parts inspected, number of defects, etc., see how to **View only defect data** (on page 368).

The example below shows what happens when Private Counters is used.

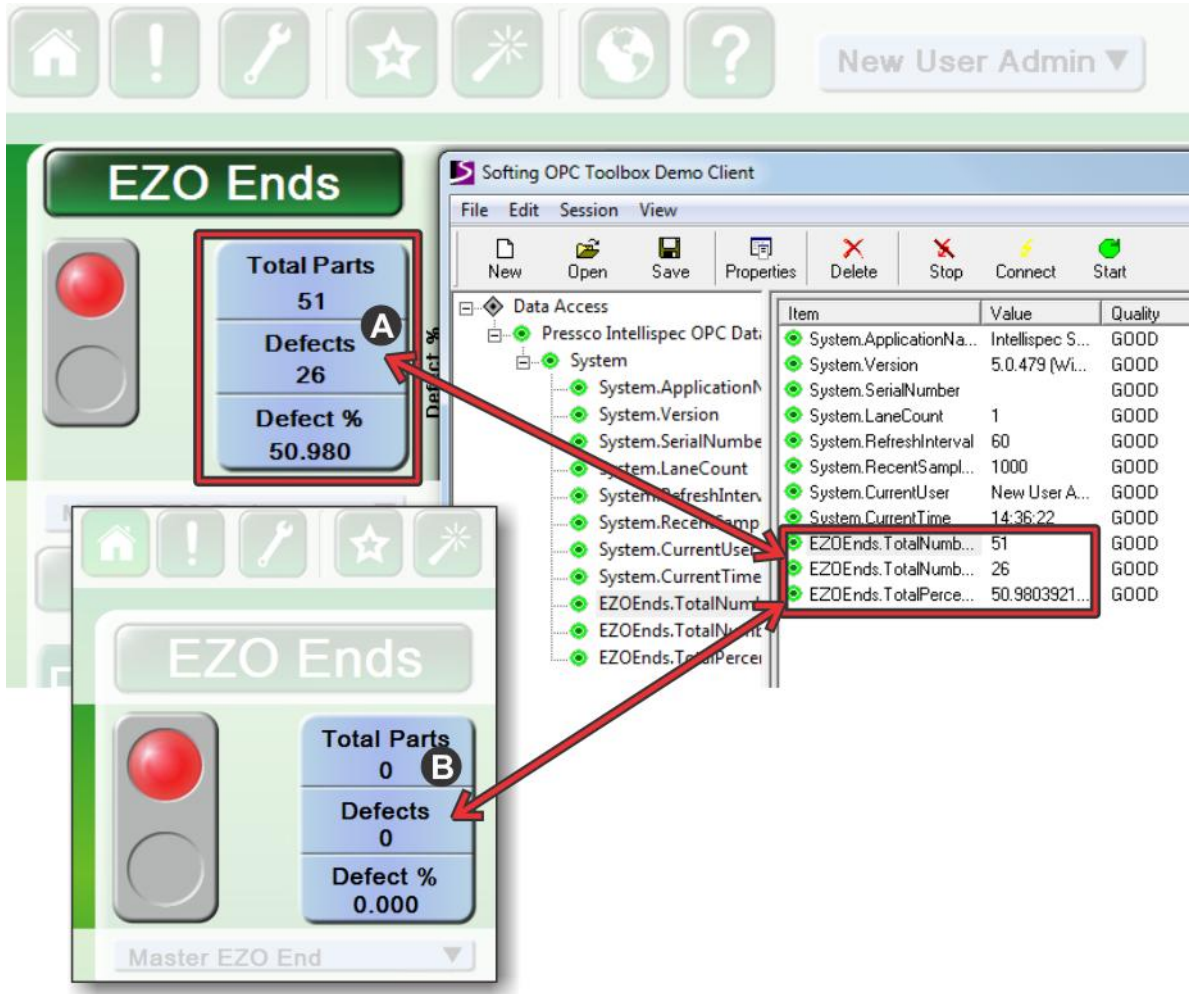



A	Normal condition. Intellispec and OPC statistics are the same.
B	Private counters enabled. The Intellispec statistics are reset, but the OPC statistics do not get reset.

## Reset Private Counters

When you use the OPC Private Counters option, you may need to manually reset the OPC data.

### ➤ To reset the OPC Private Counters:

1. Take the Intellispec system offline.
2. Log in.
3. Click the  button.
4. Click the Tools button  to see the Tools menu > select OPC Configuration. The OPC Configuration menu opens.
5. Click the **Reset Private Counters** button. A confirmation box appears to notify you that the counters will be reset on the OPC server.
6. Click OK. The OPC counters are reset.

## Counter Rollover





Counter Rollover is an advanced option for the OPC server. It allows the OPC server to behave like PLC counters if the digits are limited. For example, you may use a PLC where the data rolls over after 9,999. In this example, set the Counter Rollover value to 10,000. This would make the OPC data roll over after 9,999 to be compatible with your PLC.

❖ *Note: if your plant is **not** limited in the number of digits for your OPC counter, make sure the Use Counter Rollover box is un-checked.*

If you have a PLC that has limited digits, set the Counter Rollover to a number equal to one greater than your PLC's highest number.

- If your PLC rolls over after 9,999, set Counter Rollover to 10,000
- If your PLC rolls over after 99,999, set Counter Rollover to 100,000

### ➤ To set Counter Rollover:

1. Take the Intellispec system offline.
2. Log in.
3. Click the  button.
4. Click the Tools button  to see the Tools menu > select OPC Configuration. The **OPC Configuration** (on page 358) menu opens.
5. Check the **Use Counter Rollover** button.
6. Click either the 10,000 or 100,000 button.
7. Click the OK button to save changes and exit. The Intellispec needs to re-start for the changes to take effect.
8. Click the  button.
9. Click the Tools button  to see the Tools menu > select Exit System.
10. Select Shut Down Intellispec and Restart the Computer from the drop-down menu. The Intellispec software shuts down and restarts.
11. Log in after the software restarts, and continue operation.

## View only defect data

To see the effects of Private Counters, set up the OPC test client to show only the defect items such as parts inspected and number of defects.

Open the **The Intellispec OPC test client** (on page 359).

Next, set up the data items to display only defect information.

### ➤ To see the defect items:

1. Remove the items that you do **not** want to see by clicking each item, then clicking the Delete button at the top of the menu.

❖ Note: do not click the "System" item in the left pane. If you remove that item, then none of the statistics items will be available to view.

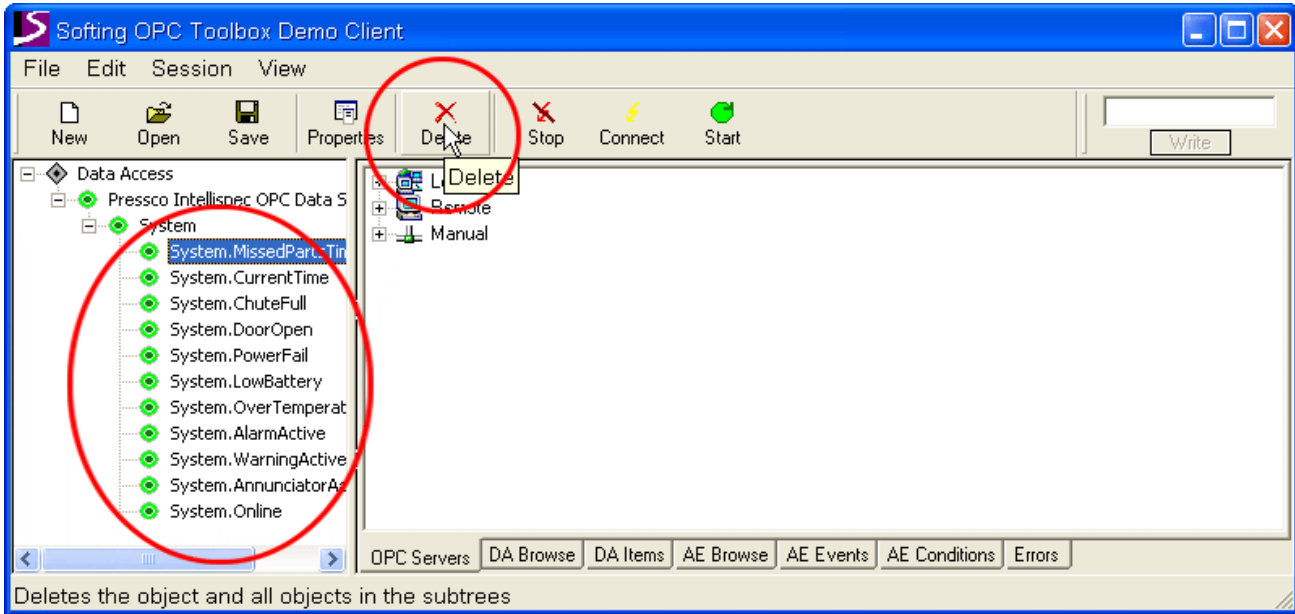

2. Click the DA Browse tab at the bottom of the window. The "Pressco Intellispec OPC Data Server" item is displayed in the right pane.
3. Click the '+' next to the Data Server item to expand the tree.
4. Click the '+' next to a Lane name to expand the Lane tree.
5. Choose the items from the right pane that you **do** want to view by double-clicking each item.

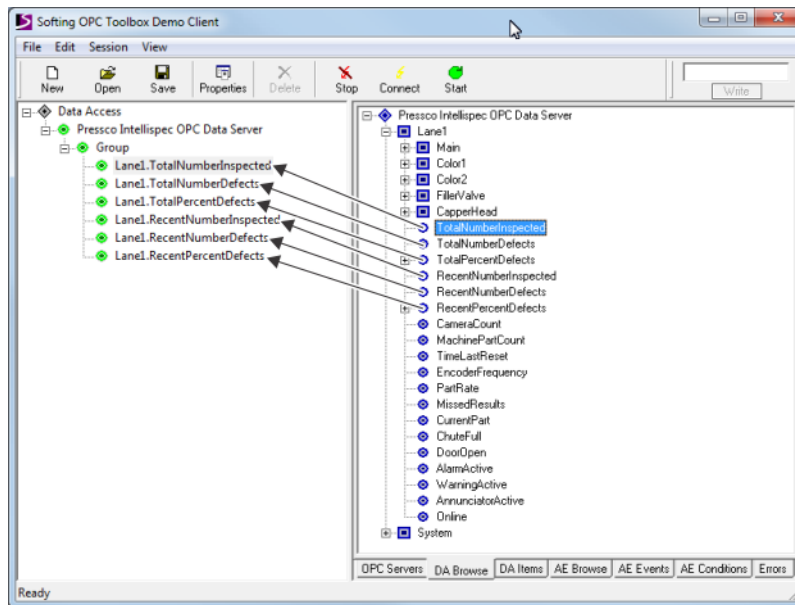

6. Continue choosing all the items you want to see. Expand the individual camera trees and choose the defect statistics for each camera, if desired.
7. Once you have all the items you want to see in the left pane, click the DA Items tab at the bottom of the window. Your selected items appear in the right pane.

Next, test the Private Counters: Put the Intellispec system online. Observe the defect data on screen and in the OPC test client. Notice that the numbers are essentially the same. Due to different update rates, the numbers may be slightly off at times.

---

# List of Data Items

The following list contains the common data item IDs that are available on the Intellispec OPC Server. Note that the names of the data items depend on your system configuration.

## **TotalNumberInspected**

Total number of parts inspected since statistics were last reset. Present for each lane, camera and inspection.

## **TotalNumberDefects**

Total number of defective parts found since statistics were last reset. Present for each lane, camera and inspection, and also for each machine part when machine part correlation is in effect (in which case this item is a one-dimensional array with each array element representing the defect count for one occurrence of the machine part).

## **TotalPercentDefects**

Percentage of defective parts per the total number of parts inspected since statistics were last reset. Present for each lane, camera and inspection, and also for each machine part when machine part correlation is in effect (in which case this item is a one-dimensional array with each array element representing the defect percentage for one occurrence of the machine part).

## **RecentNumberDefects**

The number of defective parts found in the last “N” number of parts inspected, where “N” is a configurable parameter. Present for each lane, camera and inspection.

## **RecentPercentDefects**

Percentage of defective parts found per the last “N” number of parts inspected, where “N” is a configurable parameter. Present for each lane, camera and inspection.

## **RecentSampleSize**

Gives the value of the configurable parameter “N” mentioned in the preceding “Recent...” data items. Present for System.

## **Enabled**

True if the inspection is currently enabled or False if it is disabled. Present for each inspection.

## **RejecterEnabled**

True if the rejecter for this camera or inspection is currently enabled or False if it is disabled. Present for each camera and inspection.

## **RejecterNumber**

Gives the rejecter number assigned to this camera in lanes configured to have multiple rejecters. Present for each camera.

## **TimeLastReset**

Gives the date and time statistics were last reset to zero. Present for each lane.

## **CurrentPart**

Name of the currently selected part program. Present for each lane.

## **ChuteFull**

True if the defective part container for this lane is currently full or False if it is not. Present for each lane.

## **MissedResults**

The number of parts that reached the reject point on the conveyor before the system was able to determine if the part was defective or not. Present for each lane.

## **PartRate**

The number of parts to be inspected being encountered per minute. Present for each lane.

**EncoderFrequency**

The number of encoder pulses being produced per second (which is proportional to the conveyor speed). Present for each lane.

**AlarmActive**

True if the red light on the light tree is currently illuminated or False if it is not. Present for each lane.

**WarningActive**

True if the yellow light on the light tree is currently illuminated or False if it is not. Present for each lane.

**AnnunciatorActive**

True if the horn or buzzer on the light tree is currently sounding or False if it is not. Present for each lane.

**Online**

True if parts are currently being inspected with defective parts being rejected or False if they are not. Present for each lane.

**MissedPartPresents**

Total number of parts for which a usable image was not received from the camera. Present for each camera.

**Average**

Arithmetic mean of measurement. Present for each inspection measurement.

**StdDev**

Standard deviation of measurement. Present for each inspection measurement.

**Minimum**

Lowest value of measurement. Present for each inspection measurement.

**Maximum**

Highest value of measurement. Present for each inspection measurement.

**Version**

String giving the major, minor and build numbers of the software currently running on the Intellispec system. Present for System.

**SerialNumber**

String giving the system serial number. Present for System.

**CurrentUser**

String giving the name of the user currently logged onto the system, or empty string if no user is currently logged on. Present for System.

**CurrentTime**

Current date and time as given by system clock. Present for System.

---

## References

To learn more about OPC, visit these links:

**OPC Foundation**

([http://www.opcfoundation.org/Default.aspx/01\\_about/01\\_what\\_is.asp?MID=AboutOPC](http://www.opcfoundation.org/Default.aspx/01_about/01_what_is.asp?MID=AboutOPC))

**OLE for process control** ([http://en.wikipedia.org/wiki/OLE\\_for\\_process\\_control](http://en.wikipedia.org/wiki/OLE_for_process_control))

Or perform a search on the Internet, using "OLE for process control" as the search criteria.

# Chapter 19

## How to Contact Pressco

### **24/ 7 Customer Support:**

+1 440-498-2000

### **E-mail:**

*dispatch@pressco.com* (*mailto:dispatch@pressco.com*) or *techsupport@pressco.com*  
(*mailto:techsupport@pressco.com*)

### **Customer Service Fax:**

+1 440-498-4761

### **Mailing Address:**

Pressco Technology Inc. 29200 Aurora Rd. Cleveland, OH USA 44139-1847

### **Main Phone:**

+1 440-498-2600

### **Web Site:**

*www.pressco.com* (*http://www.pressco.com*)

### **Business Hours:**

Monday - Friday, 8:00am - 5:00pm Eastern Standard Time



# Index

## A

ABOUT OPC • 357  
ABOUT THE INTELLISPEC SERIES V COMPACT SINGLE LANE (CSL) SYSTEM • 5  
ABOUT THIS MANUAL • 6  
ABSOLUTE DIFFERENCE • 211  
ADAPTIVE REGION • 200  
ADAPTIVE REJECT (OPTIONAL) • 114, 116  
ADDING A USER WITH THE BIOMETRIC LOGIN DEVICE • 50  
ADDING DATA ITEMS TO THOSE BEING MONITORED • 363  
ADDING REGIONS AND INSPECTIONS • 179  
ADJUSTING DATE AND TIME • 123  
ADJUSTING THE CP/ E SERIES MODULES • 308  
ADJUSTING THE CP4422EV MODULE • 322  
ADJUSTING THE CP500/ V MODULE • 330  
ADJUSTING THE CPX CAMERA • 334  
ADVANCED ADJUST LIGHTING • 142  
ADVANCED ADJUST LIGHTING - SET DELAY • 143  
ADVANCED ADJUST LIGHTING - ZONES • 143  
ADVANCED PARAMETER • 183  
ALARM PERCENTAGES IN TREND CHARTS • 64  
ALARMS • 11, 73  
ALARMS -- CLEARING • 74  
AMBIENT • 251  
ANALYSES • 251  
ANGLE • 291  
APERTURE ADJUSTMENT • 310  
ASSEMBLY, LOCATION, AND MOUNTING REQUIREMENTS • 27  
AUTHORIZED USERS • 16

## B

BACKGROUND TASKS • 131  
BASIC ADJUST LIGHTING • 141  
BIG LIVE IMAGE • 72  
BINARY • 207  
BIOMETRIC DEVICE • 50  
BIOMETRIC LOGIN DEVICE • 36

## C

CALIBRATING THE IMAGE PIXEL SCALE • 140

CAMERA ADJUSTMENTS • 309, 322, 330, 335  
CAMERA FOCUS AND APERTURE • 136  
CAMERA POSITION ADJUSTMENT • 310  
CENTER OF MASS • 217  
CENTERLINE • 225  
CHANGING YOUR PASSWORD • 48  
CHECKING FOR ERRORS • 365  
CHROMAPULSE MODULE EXTERNAL CONNECTIONS • 315  
CLEANING GLASS SURFACES • 352  
CLEANING OPTICAL SURFACES • 351  
CLEANING PLASTIC SURFACES • 353  
CLEANING THE CAMERA LENS • 353  
CLEANING THE CHROMAPULSE BEAM SPLITTER • 352  
CLEANING THE ELLIPSOIDAL MIRROR • 354  
CLEANING THE PART DETECTOR • 355  
CLEANING THE PART DETECTOR AND REFLECTOR • 355  
CLEANING THE USER INTERFACE ENCLOSURE FILTER • 350  
CLIPPING • 204  
COLOR DISTANCE • 211  
COLOR EXTRACTION • 213  
COMMISSIONING • 30  
CONTRAST • 255  
CORRELATION • 293  
CORRELATION DIAGNOSTICS • 110  
COUNTER ROLLOVER • 368  
CP/ E MOTORIZED FOCUS CONNECTIONS (OPTIONAL) • 320  
CP/E INSPECTION MODULE INTERNAL CONNECTIONS • 316  
CP/E POWER PANEL CONNECTIONS • 319  
CP/E SERIES MODULES • 307  
CP/EV MODULE MEASUREMENTS • 21  
CP1200E LIGHT ARRAY CONNECTIONS • 318  
CP1200E/ CP1500E • 312  
CP1500E LIGHT ARRAY CONNECTIONS • 318  
CP4422E MODULE EXTERNAL CONNECTIONS • 323  
CP4422EV AUXILIARY MODULE INTERNAL CONNECTIONS • 329  
CP4422EV INSPECTION MODULE • 321  
CP4422EV INTERNAL CONNECTIONS PAGE 1 • 325  
CP4422EV INTERNAL CONNECTIONS PAGE 2 • 326  
CP4422EV INTERNAL CONNECTIONS PAGE 3 • 328  
CP500 INSPECTION MODULE • 330

- CP500 INSPECTION MODULE INTERNAL CONNECTIONS
  - 331
- CP500 MOTORIZED FOCUS CONNECTIONS (OPTIONAL)
  - 332
- CP500E LIGHT ARRAY CONNECTIONS • 317
- CP750E LIGHT ARRAY CONNECTIONS • 317
- CPX INSPECTION MODULE • 333
- CPX INTERNAL CONNECTIONS • 336
- CREATING A SUPPORT PACKAGE • 124
- CSL USER INTERFACE DIMENSIONS • 19
- CSL USER INTERFACE ELECTRICAL SPECIFICATIONS • 18
- CSL USER INTERFACE SELECTION DEVICES • 33
- CSL USER INTERFACE WEIGHTS • 20

## D

- DECLARATION OF CONFORMITY - INTEGRATED TUNNEL • 24
- DECLARATION OF CONFORMITY - INTELLISPEC™ CSL SYSTEM • 23
- DELETE A PART PROGRAM • 99
- DESIGN MODE ICON • 179
- DIMENSIONS • 287
- DISCOVERY - ACCESS AND USE • 130
- DISCOVERY MENU TOOLBAR • 130
- DISCOVERY SOFTWARE - WHAT IS DISCOVERY? • 129
- DISCOVERY SOFTWARE SCREEN • 129
- DISTANCE • 287
- DISTRIBUTION • 277
- DISTRIBUTION HISTOGRAM TYPES • 281

## E

- EDIT A PDL FILE • 148
- EDITING NUMERIC VALUES • 183
- EDITING PARAMETERS • 182
- EDITING PERMISSIONS • 56
- EDITOR OPTIONS • 183
- ELECTRICAL CONNECTION • 29
- EMPTY POCKET • 191
- ENHANCEMENTS • 203
- ENVIRONMENTAL CONDITIONS • 17
- ERROR MESSAGES • 91
- EXITING THE INTELLISPEC SOFTWARE • 44
- EXITING THE TEST CLIENT • 365
- EXPORT A PART PROGRAM • 101
- EXPORTING USER ACCOUNTS • 51
- EXTENDED I/O • 337

- EXTENDED I/O BOARD • 337
- EXTENDED I/O CIRCUITS • 343
- EXTENDED I/O CONFIGURATION • 344
- EXTENDED I/O IN INSPECTION MODULES • 306, 344
- EXTENDED I/O SIGNALS • 338
- EXTENDED I/O TERMINAL BLOCK REFERENCE • 342

## F

- FAVORITES MENU • 131
- FEATURE • 216
- FEATURE DETECT • 284
- FEATURE DETECT - EXAMPLE FHCP 3X • 286
- FILL HEIGHT • 269
- FINISH LOCATION • 228
- FOCUS ADJUSTMENT • 310, 322
- FORCED REJECT • 105

## G

- GAMMA CORRECTION • 208
- GO ONLINE AT STARTUP • 123
- GRAPHS AND IMAGE DISPLAYS • 59
- GROW DARK AREAS • 209
- GROW LIGHT AREAS • 210

## H

- HARDWARE SETUP • 108
- HELP • 44
- HELP - REMOTE SUPPORT • 127
- HOUGH • 219
- HOUGH VS. RADIAL EDGE • 215
- HOW TO CONTACT PRESSCO • 373
- HOW TO CREATE, COPY, OR IMPORT A PART PROGRAM • 169
- HOW TO SELECT MENU ITEMS • 33

## I

- I/O DIAGNOSTICS • 108
- IMAGE ANALYSIS • 138
- IMAGE DISPLAY CONFIGURATION • 96
- IMAGE OPTIONS • 165
- IMAGE SOURCE • 145
- IMAGES - LOADING • 163
- IMAGES - SAVING • 153
- IMPORTING USER ACCOUNTS • 52
- INSPECTION EDITOR • 181
- INSPECTION MENU • 172
- INSPECTION MODULES • 305

- INSPECTION OVERVIEW • 167
- INSPECTION OVERVIEW SCREEN • 42
- INSPECTION TERMINOLOGY • 167
- INSPECTION TREE RELATIONSHIPS • 178
- INSPECTION TYPE ICONS • 176
- INSPECTIONS • 191
- INSPECTIONS GRAPH • 68
- INSTALLATION • 30
- INSTALLATION AND WIRING • 25
- INTEGRATED TUNNEL ELECTRICAL SPECIFICATIONS • 20
- INTELLISPEC CSL CABINET AND USER INTERFACE • 31
- INTENDED USE • 12
- INTERPRETING THE DATA • 361
- INTRODUCTION • 5

## L

- LABEL SKEW EXTRACT • 282
- LANE ALARM CONFIGURATION • 76
- LANE ALARMS DESCRIPTION • 79
- LANE DETAIL REPORT • 88
- LANE OVERVIEW SCREEN • 40
- LANE SETUP • 95
- LANE SUMMARY REPORT • 87
- LANGUAGE • 43
- LIFTING HEAVY OBJECTS • 15
- LIGHT TREE • 11, 302
- LIGHT TREE STATUS • 302
- LIGHTING ADJUSTMENTS • 311, 322, 330, 335
- LIGHTING AND IMAGING • 135
- LIGHTING ZONES CP4422E • 323
- LIGHTING ZONES CP500 • 331
- LIGHTING ZONES CP500E/ CP750E • 311
- LIGHTING ZONES CPX • 336
- LIST OF DATA ITEMS • 370
- LOAD A PART PROGRAM • 100
- LOAD A PDL FILE • 147
- LOADING SAVED IMAGES • 163
- LOG IN MENU • 47
- LOG READER • 90
- LOGGING IN AND LOGGING OUT • 47

## M

- MACHINE PART CORRELATION • 96
- MACHINE PART GRAPHS • 67
- MAINTENANCE FREQUENCY • 349

- MANAGE PART PROGRAMS • 99
- MANAGE SIMULATED LANE IMAGES (PDL) • 146
- MANAGING PERMISSIONS • 53
- MANAGING USER ACCOUNTS • 49
- MARKING • 10
- MEASURE EXTRACT • 275
- MEASURE ROI • 198
- MEASUREMENT • 261
- MEASUREMENT DATA ITEMS • 363
- MECHANICAL KEYBOARD (MKB) • 35
- MENU TOOLBAR • 42
- MISCELLANEOUS CONFIGURATION • 103
- MISSED PACKETS EXCEPTION • 120
- MODULE HEIGHT ADJUSTMENT • 308
- MONITOR • 32
- MORE LANE INFORMATION • 40
- MULTIPLE TREND GRAPHS • 63

## N

- NAVIGATING THROUGH THE SYSTEM • 31
- NON-INTENDED USE • 13

## O

- OBSERVE PART IMAGE • 305
- OFFLINE IMAGING • 137
- ON SCREEN KEYBOARD (OSK) • 34
- ONLINE / OFFLINE • 44
- OPC CONFIGURATION • 358
- OPTIONS (SENSOR MENU) • 177
- ORIENTATIONS • 244

## P

- PARAMETER DATA ITEMS • 364
- PART CHANGEOVER • 171
- PART PRESENT DELAY CALIBRATION • 110
- PART PRESENT DELAY WITH ENCODER • 112
- PART PROGRAM CHANGE LOG • 174
- PART RATE • 94
- PART SETUP • 92
- PART TRACKER EXCEPTION • 120
- PART TRACKER SIMULATION • 118
- PART TRACKING • 168
- PART WIDTH CALIBRATION • 92
- PATTERN MATCH • 244
- PDL - IMAGE LIST • 146
- PDX CONFIGURATION • 119

PERSONAL PROTECTIVE EQUIPMENT • 13  
PERSONNEL SAFETY • 14  
PIXELS TO INCHES • 144  
PIXELS TO MILLIMETERS • 144  
POLYGON REGION • 194  
POWER DOWN • 295  
POWER UP • 295  
PRESSCO PC OUTLET WIRING • 296  
PROTECTIVE EARTHING • 28

## R

RADIAL EDGE • 223  
REBOOTING THE INTELLISPEC SYSTEM • 300  
RECOMMENDATIONS FOR IMAGE FILE MANAGEMENT  
• 155  
RECOMMENDATIONS PRIOR TO INSTALLATION • 26  
REFERENCES • 372  
REGION EDITOR • 180  
REGION OF INTEREST COMPATIBILITY CHART • 192  
REGIONS OF INTEREST (ROI) • 192  
REGISTRATIONS • 215  
REJECT CONFIRM CALIBRATION (OPTIONAL) • 120  
REJECT DELAY CALIBRATION • 113  
REJECT IMAGES • 65  
REJECTOR ENABLE/ DISABLE • 104  
REMOTE PART PROGRAM SWITCHING • 102  
REPLACING CAMERA • 311  
REPLACING FILTER/ REGULATOR FILTERS • 356  
REPLACING/ CLEANING THE CHROMAPULSE CP4422EV  
FAN FILTERS • 351  
REPORTING • 86  
RESET PRIVATE COUNTERS • 367  
RESIDUAL RISK • 12  
RESULT OPTIONS • 184  
RETRO-SPEC OPTIONS • 187  
RETRO-SPEC PART VIEW GRAPH • 188  
RETRO-SPEC POPULATION VIEW GRAPH • 185  
REVIEW CAMERA CALIBRATION • 144  
RIBBON REGION • 196  
RING REGION • 193

## S

SAFETY CONSIDERATIONS • 7  
SAFETY INFORMATION • 9  
SAVING A REGION OF INTEREST (UNWRAPPED) IMAGE  
• 162

SAVING IMAGES • 150  
SAVING IMAGES AUTOMATICALLY • 151  
SAVING IMAGES THROUGH THE RETRO-SPEC  
INTERFACE • 153  
SAVING IMAGES THROUGH THE SENSOR MENU • 150  
SAVING INDIVIDUAL IMAGES WHILE EDITING AN  
INSPECTION • 157  
SAVING INDIVIDUAL REJECT IMAGES • 161  
SAVING REJECT IMAGES • 158  
SAVING REJECT IMAGES BY INSPECTION • 158  
SAVING REJECT IMAGES BY MACHINE PART • 160  
SCHEDULE REPORTS • 88  
SELECT SENSOR IMAGES • 149  
SENSOR ALARM CONFIGURATION • 80  
SENSOR ALARMS DESCRIPTION • 83  
SENSOR INFORMATION • 40  
SENSOR MENU • 135  
SENSOR MISSED STATISTICS • 91  
SENSOR OVERVIEW SCREEN • 41  
SEQUENCE OF EVENTS DURING INSPECTION • 168  
SERVICING THE USER INTERFACE • 295  
SETTING UP A PRINTER • 124  
SETTING UP AUTO LOGOUT • 57  
SHAPE CHECK • 254  
SHIPPING AND HANDLING • 25  
SOFTWARE UTILITIES • 123  
SOUND PRESSURE LEVEL • 17  
SPARE PARTS USAGE • 16  
SPECIFICATIONS • 18  
STATIC DISCHARGE PROTECTION • 7  
STATISTICS CONFIGURATION • 70  
STATISTICS GRID • 69  
STATISTICS GRID CONFIGURATION • 107  
STATISTICS GRID OPTIONS • 71  
STATISTICS MENU • 40  
STRETCH GRAYSHADES • 206  
STRETCH GRAYSHADES EXAMPLE • 207  
SUBTRACT BIAS • 204  
SUPPORT RING REGISTRATION • 240  
SWITCH SIDES • 309  
SWITCHING USERS • 48  
SYMBOLS • 9  
SYSTEM ALARMS DESCRIPTION • 76  
SYSTEM BLOCK DIAGRAM - CSL • 27  
SYSTEM HARDWARE INFORMATION • 295

SYSTEM OVERVIEW SCREEN • 39

SYSTEM SPECIFICATIONS • 17

## T

TAKE SCREEN SHOT • 131

TEMPLATE ORIENTATION • 246

TEMPLATE REGISTRATION • 231

THE INTELLISPEC OPC SERVER • 357

THE INTELLISPEC OPC TEST CLIENT • 359

TIMING - INSPECTION • 184

TIMING TREND • 68

TOOLS MENU - LANE OVERVIEW AND SENSOR  
OVERVIEW SCREENS • 86

TOOLS MENU - SYSTEM OVERVIEW SCREEN • 85

TOOLS MENUS • 85

TOUCH SCREEN MONITOR (OPTIONAL) • 32

TRASH CAN ICON • 104

TREND CHART CONFIGURATION - LANE OVERVIEW •  
64

TREND CHART CONFIGURATION - SYSTEM OVERVIEW •  
63

TREND GRAPHS • 62

TYPOGRAPHICAL CONVENTIONS • 6

## U

UNWRAPPED REGION OF INTEREST OPTIONS • 185

USB PORTS • 36

USER ACCOUNTS AND LOGIN INFORMATION • 47

USER INTERFACE • 18

USER INTERFACE DISPLAY - 4 LEVELS • 36

USER INTERFACE EXTERNAL CONNECTIONS - 120VAC  
UPS • 297

USER INTERFACE EXTERNAL CONNECTIONS - 230VAC  
UPS • 298

USER INTERFACE INPUT DEVICES • 32

USER INTERFACE INTERNAL CONNECTIONS • 299

USING THE OPC PRIVATE COUNTERS OPTION • 365

USING THE WALK BY GRAPHIC • 60

UTILITIES TO BE SUPPLIED BY CUSTOMER • 27

## V

VENTILATION • 30

VIEW ONLY DEFECT DATA • 368

VIEWING AND CLEARING ALARMS • 74

## W

WALK BY GRAPHIC • 59

WALK BY SETUP • 60

WARNING DEVICES • 11

WARNINGS • 83, 187

    disable inspection warnings • 103

WIRING DIAGRAM TRACKBALL • 300

WIRING DIAGRAMS • 296